BELARUS TRACTORS

900/900.3

920/920.2/920.3

950/950.3

952/952.2/952.3

900 – 0000010 OM

OPERATING MANUAL

2009

IMPORTANT!

If the tractor is operated by the user or lent/leased, make sure that the operator prior to working on the tractor:

- A.** has been instructed on safety measures and proper tractor use;
- B.** has studied and understood the content of this Operating Manual.

NOTE!

Due to continual improvement of the products manufactured, some modifications not reflected herein may be made to the design of some subassemblies and parts. Some technical data and illustrations given herein may differ from the actual ones for your tractor. The dimensions and weights are approximate (reference). For the detailed information, contact the BELARUS trademark dealer.

General note: The references to the “left” and “right” in the text of this Manual are given from the standpoint of the observer staying behind the tractor moving ahead.

Table of Contents

Introduction	6
Adopted Abbreviations and Symbolic Notations	8
International Symbols	9
Safety Precautions	11
Technical Data	15
Controls and Instruments	32
Operating Instructions	81
Unitization	127
Adjustments	155
Maintenance	170
Troubleshooting	219
Tractor Transportation and Towing	227
Tractor Storage	228
Appendix A. Electric Equipment	229

All rights reserved. This book shall not be reproduced or copied either fully or partially without written permission of the Minsk Tractor Works Republican Unitary Enterprise.

ATTENTION OF THE TRACTOR OPERATORS!

1. Prior to operating the tractor, read carefully this User Manual and follow strictly its requirements.
2. Apply the climatic diesel fuel according to the Manual. Reduce the motor oil changeover intervals by half, if the sulphur content in the fuel is below 1%.
3. Do not allow the diesel engine idling for more than 15 minutes.
4. Please keep in mind that the engine can be only started when the gearbox lever is set to the leftmost position (to the position of engagement of the 1st or 2nd range of gears).
5. When operating the tractor without the rear PTO, put the switchover shifter arm of the independent two-speed PTO drive to position I (540 rpm), the independent synchronous PTO drive – to the neutral (middle) position and the control lever – to the position “PTO OFF” (refer to Section “Operating controls and Instrumentation”).
6. Use the synchronous PTO drive at the tractor unit movement speeds not exceeding 8 km/h. Otherwise, severe damages of the tractor transmission can be caused.
7. The tractor should be only operated at the 9th gear with the higher gear range (range II) engaged.
8. The tractor cab is equipped with a single seat and only the operator must be in.
9. When shipping the tractor from the factory, some tractor components are packed in the box of spare parts and accessories, toolbox or cab. Fit them onto the tractor by your own.
10. When putting new storage batteries into operation, remove the airtight film from the air holes or cut the lugs on PE plugs off.
11. Do not allow tractor operation with the clutch disengaged or incompletely engaged.
12. When starting the movement, make sure that the manual reserve parking brake is off.

13. When using the tractor without drive shafts, put FDA lever to position “forced”.
14. Do not operate the tractor indoors without adequate ventilation (air exchange). Exhaust gases can lead to fatal outcome.
15. Towing the tractor with front wheels lifted is strictly forbidden. Otherwise, the FDA drive failure and emergency situation can occur.
16. Never lift the tractor by the front part of the tractor by the towing shackle. Use the shackle for towing only.
17. The manufacturer is improving continually the tractor due to that there could be some modifications of the design of some components and their operating rules is not reflected in this Manual.

INTRODUCTION

The BELARUS wheeled universal tilling tractors of the 900 series belong to drawbar category 1.4 and are designed to perform a wide range of agricultural works: from soil preparation for sowing to harvesting and transporting operations; they can be used in forestry, municipal servicing, construction and industry.

This Manual contains the description of the design peculiarities, brief technical data and recommendations for operation and maintenance of the following BELARUS tractors of 900 series:

BELARUS- 900 (4x2) with the Д-243/Д-243С diesel engine (59.6 kW/2200 rpm) and synchronized gearbox;

BELARUS-900.3 (4x2) with the Д-245.43 S2 diesel engine (62 kW/1800 rpm), synchronized gearbox and updated design;

BELARUS-920 (4x4) with the Д-243/Д-243С diesel engine (59.6 kW/2200 rpm), synchronized gearbox and FDA (72);

BELARUS-920.2 (4x4) with the Д-243/Д-243С diesel engine (59.6 kW/2200 rpm), synchronized gearbox, FDA (822) and updated design;

BELARUS-920.3 (4x4) with the Д-245.43 S2 diesel engine (62 kW/1800 rpm), synchronized gearbox, FDA (822) and updated design;

BELARUS-950 (4x2) with the Д-245.5/Д-245.5С diesel engine (65 kW/1800 rpm), synchronized gearbox;

BELARUS-950.3 (4x2) with the Д-245.5 S2 diesel engine (65 kW/1800 rpm), synchronized gearbox and updated design;

BELARUS-952 (4x4) with the Д-245.5/Д-245.5С diesel engine (65 kW/1800 rpm), synchronized gearbox and FDA (72);

BELARUS-952.2 (4x4) with the Д-245.5/Д-245.5С diesel engine (65 kW/1800 rpm), synchronized gearbox, FDA (822) and updated design;

BELARUS-952.3 (4x4) with the Д-245.5 S2 (70 kW/1800 rpm) diesel engine, synchronized gearbox, FDA (822) and updated design.

Index “.2” means upgrading of the respective model by installing one or several units of higher engineering level:

- FDA with planetary reducing gears (for 4x4 tractors);
- Hydraulic lift-based hookup;
- Bonnet, roof, cab fender of updated design.

Index “.3” means installation of diesel engines with index S2 certified as per the 2nd stage of the ecological regulation of Directive 2000/25/EC, hydrostatic power steering (HPS) system with an independent oil tank, as well as the bonnet, the roof and cab fenders of renewed design.

Making any re-equipment or modifications to the tractor design, which are not authorized by the Manufacturer is strictly forbidden.

The distinctive features of the tractors described in the Manual:

1. Transmission with synchronized gearbox (7/2) and synchronized reducing gear (step-up gear): 14 forward and 4 reverse gears.
2. Hydrostatic power steering with the Danfoss metering pump, cylinder in steering trapezium and steering tie rod.
3. Unified rear driving axle with more convenient external readjustment of planetary gear brake bands.
4. Hydraulic system with a power regulator completely controlling the rear attachment cylinder. Three sections of the distributor ensure the control of external cylinders of machines and tools.
5. Safe comfortable cab meets the requirements of EC and OECD directives and is featured by the improved interior, heating and ventilation system.



















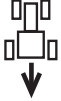









Adopted Abbreviations and Symbolic Notations



















SB	—	storage battery
DL	—	differential lock
PCU	—	pre-heater control unit
SCU	—	starter control unit
UDP	—	diesel piston upper dead point
PTO	—	power take-off shaft
HMS	—	hydraulic mounted system
HPS	—	hydrostatic power steering
LOHE	—	liquid oil heat exchanger
RMA	—	rear mounted attachment
ID	—	integrated display
GB	—	gearbox
C	—	clutch
CAC	—	charge air cooler
FDA	—	front driving axle
ADCS	—	automatic tilling depth control system
M	—	maintenance
DHM	—	traction hitch mechanism
SRU	—	speed reducer
ETPP	—	electric torch pre-heater
OECD	—	Organization for Economic Cooperation and Development

International Symbols

Manufacture uses standard international symbols concerning the application of devices and the controls.

Below are given the symbols with their meaning.

	— See Manual		— Control manipulations
	— Brake		— Fast
	— Parking brake		— Slow
	— Horn		— Forward
	— Emergency alarm		— Reverse
	— Fuel level in the tank		— Battery charging
	— Cooling fluid		— Cab light
	— Starting flame preheater		— Clearance lights
	— Engine speed		— Turn indicator
	— Oil pressure in the engine		— Upper beam
	— Engine cooling fluid temperature		— Lower beam
	— Off/Stopped		— Working lights
	— On/Start		— Differential locking
	— Ramping		— PTO engaged
	— Lever – down		— FWD engaged

	— Lever – up		— Fan
	— Lifting position of the distributor sliding valve		— Windscreen washer
	— Lowering position of the distributor sliding valve		— Windscreen wiper
	— Floating position of the distributor sliding valve		— Rear screen wiper
	— Oil pressure in the gearbox		— Trailer turn indicator
	— Air pressure in the pneumatic system		— Oil pressure in the hydrostatic power steering
	— High voltage		— Oil pressure in the transmission
	— Cooling fluid level		— Brake fluid level
	— Road train lights		— Air pressure in the brake system
	— Air filter clogging		

SAFETY PRECAUTIONS

Strict observance of safety precautions, accurate execution of tractor driving and operation regulations and maintenance shall guarantee complete safety of its application.

Safety precautions when operating the tractor

ATTENTION! When starting up the engine and operating the controls, **always stay in the cab on the operator's seat**

General Instructions

- Prior to tractor use, study operator's manual carefully. Insufficient knowledge on tractor driving and operation can result in accidents.
 - Specially trained and qualified operators only are allowed to operate the tractor.
 - If the tractor is equipped with a safety belt, use it during operation. If not, contact the dealer.
 - Never admit a passenger to the cab unless the latter is provided with an additional seat and hand-rail. There is no other safe seat for a passenger in the cab!
 - Keep all warning plates clean. In case of their damage or loss, replace them by new ones.
 - Prior to operation, carefully inspect the tractor and a trailed mechanism. Start operation having made sure that they are in good repair. The trailed agricultural mechanisms and transport trailers shall be fitted with rigid hitches excluding their swinging and rear-end collision with the tractor during transportation.
 - Prior to starting the diesel engine, the parking brake shall be applied; the gear shift lever shall be set to the neutral position and the PTO lever – in the OFF position.
 - Prior to starting the movement, warn the bystanders and the persons working on the trailed mechanisms with a horn.
 - Never leave the moving tractor.
 - Prior to leaving the cab, disengage the PTO, stop the engine, apply the parking brake, take off the starter switch key and set the battery disconnect switch to the OFF position.
- It is forbidden to de-energize the electric equipment system by the starter and instrumentation switch and/or battery disconnect switch until the engine is stopped.
- Do not operate the tractor indoors without necessary ventilation. Exhaust gases can result in fatal outcome!
 - In case of failure of the engine or steering control, stop the tractor immediately. Keep in mind that turning the steering wheel for controlling the tractor when the engine is stopped requires much more force. In case of failure of the steering control, a lamp of emergency oil pressure in the HVSS lights up.
 - Do not work under lifted agricultural implements. During durable stops, leave the attached implement lifted.
 - If the front part of the tractor takes off when attaching heavy mechanisms and implements, mount front weights.
 - When operating the front lift, fill in the rear tires with liquid ballast.
 - Prior to lifting and lowering the attached agricultural implements as well as when turning the tractor, make sure that there is no risk of hitting or snagging on somebody or

any obstacle.

- When moving with attached mechanisms or implements, always apply a mechanism to lock on the attachment in lifted position.
- The drive shaft transferring the rotation from the tractor PTO to the driven components shall be enclosed.
- Make sure that any additional equipment or auxiliaries are installed correctly and that they are designed for application with your tractor. Keep in mind that your tractor, if used unduly can be dangerous both for yourself and other persons. Do not operate equipment not designed for installation on the tractor.
- To avoid turnover, be careful when driving the tractor. Choose safe speed corresponding to road conditions, particularly when driving cross-country, passing the ditches, slopes and during sharp turns.
- When operating on the slopes, increase the tractor track to the maximum value.
- Do not make sharp turns under full load and high speed.
- When using the tractor for transportation works:
 - increase the tractor track to at least 1800 mm;
 - interlock the brake pedals, check and, if necessary, adjust the brakes to synchronous action;
 - check operation of the parking brake, brake pneumatic drive and trailer brakes;
 - check the state of the light and audio alarm devices;
 - transport trailers shall be fitted with rigid hitches and connected by means of the safety chain or rope;
 - never drive downhill with

switched-off gear (coasting), apply the same gear both down and uphill;

- it is forbidden to work with the trailer without independent brakes, if its weight exceed half actual weight of the tractor. The faster you move and the larger the towed mass is, the larger the safety distance shall be;
- disengage the FDA to avoid excessive wear and tear of the drive parts and tires;
- do not use rear axle differential lock (DL) at the speed of above 10 km/h and during turns;

Important! Use the synchronous PTO drive at the lower gears of the gearbox at the tractor movement speed not exceeding 8 km/h. Otherwise, the tractor's power train can be severely damaged.

- do not stop the tractor on the slopes. If the stop is still necessary, engage the 1st gear and apply the parking brake.
- when operating the equipment driven by PTO, make sure that the PTO coupler shank has fully stopped after stopping the engine before leaving the cab and disconnecting the equipment.
- Do not wear loose clothes when operating PTO or near the rotating equipment.
- When operating stationary mechanisms driven by PTO, always apply the parking brake and lock on the rear wheels from the front and behind. Make sure that the mechanism has been reliably secured.
- Make sure that the PTO coupler shank protection has been installed and, if the PTO is not used, refit the cap of the PTO coupler shank.

- Do not clean, adjust or maintain the equipment driven with PTO, when the engine is running.

Safety precautions during the maintenance

- Never refuel the tractor when the engine is running.
 - Never smoke when refuelling.
 - Never fill the tank to the top. Leave some space for fuel expansion.
 - Never add gasoline or mixtures to diesel fuel. These combinations can increase the risk of fire or explosion.
 - Use the summer or winter fuel grades properly. Refill the tank at the end of each day to reduce night moisture condensation.
 - To avoid fuel spillage during the mechanized refuelling of the tractor, remove the mesh filter from the fuel tank neck. The mesh filter is designed for tractor manual refuelling under field conditions.
 - Fill in the tractor with oils and lubricants recommended by the manufacturer. Application of other lubricating materials **is strictly forbidden!**
 - Any operations related to cleaning the engine and tractor, pre-operation, maintenance, etc. should be performed with the engine stopped and tractor braked.
 - Cooling system operates under pressure, which is maintained by a valve installed in the cap of the filler neck. **It is dangerous to remove the lid on the hot diesel engine.** To avoid burns of hands and face, unplug the radiator neck cap on the hot engine carefully, having put a thick cloth on the cap and a gauntlet on the hand.
- To avoid burns, be careful when draining the cooling fluid or water from the cooling system and/or hot oil from the engine, hydraulic system and transmission.
 - When servicing the storage batteries, be careful because the contact of electrolyte with the skin causes burns.
 - To avoid the risk of explosion, keep any sources of open flame away from the engine fuel system and storage batteries.
 - Keep the tractor and its equipment, particularly the brakes and steering, in serviceable condition to ensure your and bystanders' safety.
 - Do not make any modifications to the tractor or any parts thereof without approval of your dealer and manufacturer.

Safety requirements during operation and maintenance of electrical equipment

- To avoid damage of semiconductor devices and resistors, observe the following precautions:
 - do not disconnect the storage battery (SB) terminals with the engine running. This will cause peak voltage to appear in the discharge circuit and lead to unavoidable failure of diodes and transistors;
 - do not disconnect electric cables until the engine is shut down and all switches are off;
 - do not allow a short circuit to occur due to incorrect wire connection. Short circuit or wrong polarity will cause failure of diodes and transistors;
 - do not connect the SB to electrical equipment system until the polarity

of outputs and voltage is verified;
- do not check the presence of electric current by producing a spark, since this would lead to immediate breakdown of the transistors.

Hygienic requirements

- Fill in a vacuum flask with fresh portable water daily.
- First-aid kit shall be necessarily stuffed with bandages, tincture of iodine, ammonia spirit, borated petrolatum, soda, validol and dipyrone.
- Depending on the operating conditions, use the natural ventilation of the cab or the latter's heating and cooling unit.
- Should the durations of the continuous work on the tractor exceed 2.5 hours within a working shift, the noise protection facilities to State Standard ГOCT 12.4.051-87 (ear-plugs, antiphones) shall be used.

Fire safety requirements

- The tractor shall be provided with fire-fighting equipment, i.e. a spade and fire extinguisher. It is forbidden to operate the tractor without fire-extinguishing equipment.
- The places for parking the tractor and storing the combustible and lubricating materials shall be tiled with a strip of min 3 m wide and provided with fire-extinguishing equipment.
- Do not allow manifold and silencer soiling with dust, fuel, straw, etc.
- Do not allow straw to wind around rotating parts of mechanisms unitized with the tractor.
- When washing the parts and assembly units in kerosene or gaso-

line, take measures excluding ignition of flushing liquid vapours.

- Do not operate the tractor in fire-risky place with the bonnet and other protective facilities removed from the heated engine parts.
- Do not allow using open flame to heat oil in engine pan or burn out soiling of radiator core.
- If a seat of fire occurs, strew sand over it and cover it with tarpaulin, sack cloth or other thick fabric. Use a carbon dioxide fire extinguisher. Do not extinguish burning fuel with water.
- Watch that there are no highly inflammable materials near the manifold and the silencer when the engine is running.
- When harvesting hay, straw, working in places of higher fire risk, apply spark suppressors in the exhaust system as an assembly with the silencer or independently.

SPECIFICATIONS

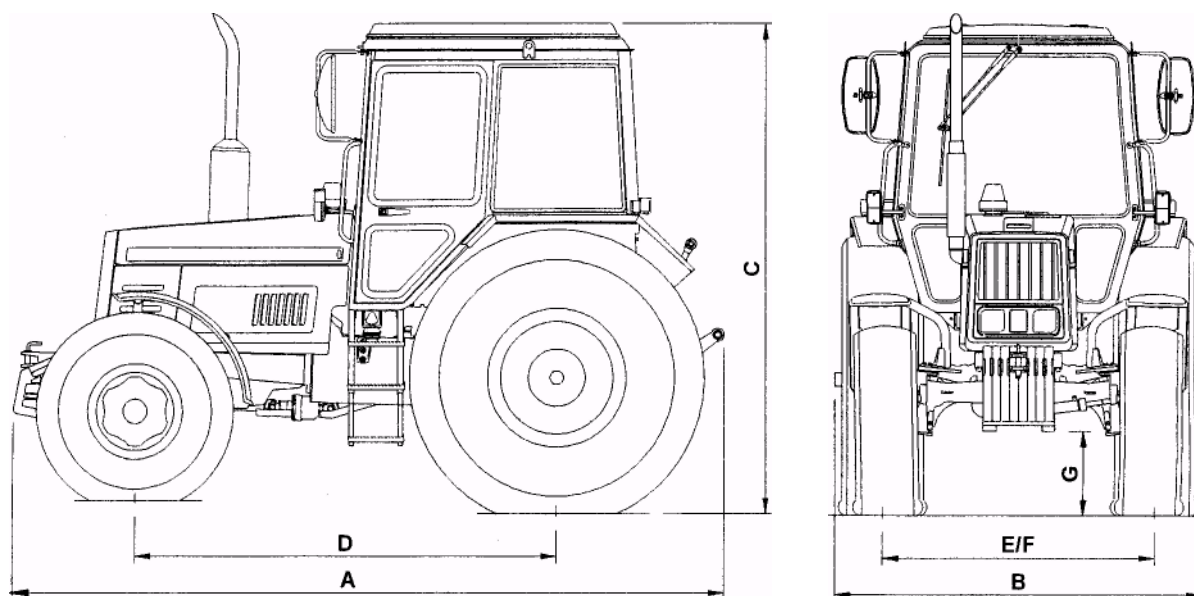

Parameter	900/900.3	920/920.2/920.3	950/950.3	952/952.2/952.3
A Length, mm: total	4120/4440	4120/4130/4440	4120/4440	4120/4130/4400
without weights	3840/4440	3970/4000/4060	3840/4060	3970/4000/4060
to wheels	3700	3840/3850/3850	3700	3840/3850/3850
B Width, mm	1970			
C Height to cab top, mm	2820	2850	2820	2850
D Longitudinal base, mm	2370±20	2450±20	2370±20	2450±20
E Rear wheel track, mm	1500-1600/1800-2100			
F Front wheel track, mm	1450-1850	1410-1990/1420-1970	1450-1850	1410-1970/1420-1970
G Clearance, mm	465			
Tire size: front wheels	9,00-20;9,00R20	13,6-20;360/70R24	9,00-20;9,00R20	13,6-20;360/70R24
rear wheels	18,4R34 (Φ-11)	16,9R38; 18,4R34 (Φ-11)	18,4R34 (Φ-11)	16,9R38; 18,4R34
Service weight (without ballast), kg	3850/3950	4100/4200/4300	3850/3950	4100/4200/4300

Numbers of tractor component parts

Name plate of the tractor containing the serial numbers of the tractor and engine.

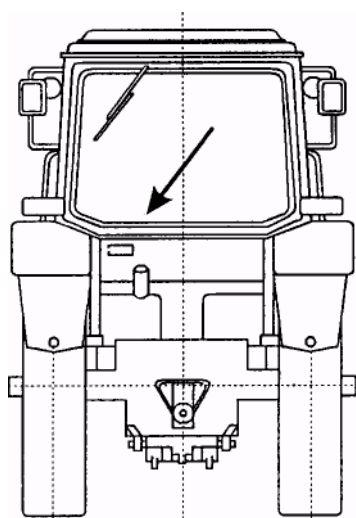

The serial number of the tractor is replicated on the front end of the right-hand side member of the half-frame (on the right plate of front balance weights).

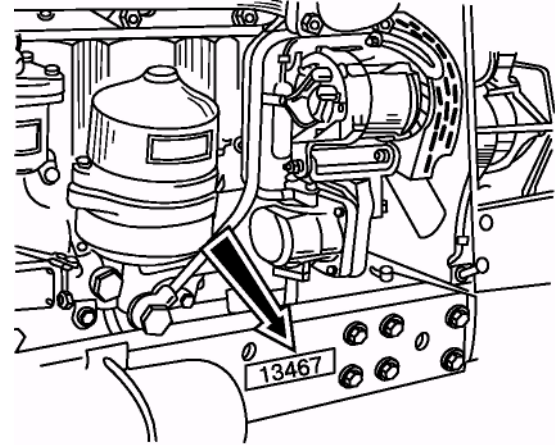

Engine number (is duplicated on engine name plate attached on the right of the cylinder block).

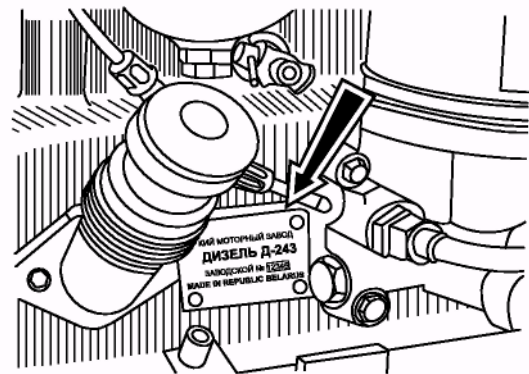

Clutch number (on the left of the clutch housing).

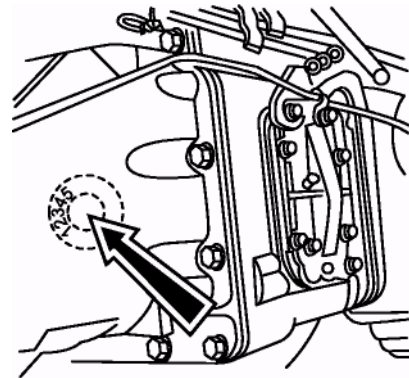

Gearbox number (on the left of the gearbox housing)

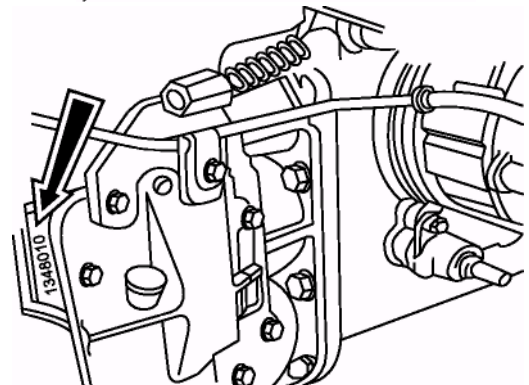

Transmission number (on the rear axle housing from behind).

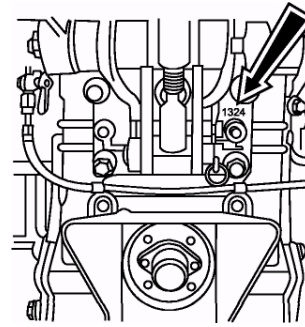

Transmission number for the tractor with hydraulic lift (on the rear axle housing at the joint with the gearbox on the right).

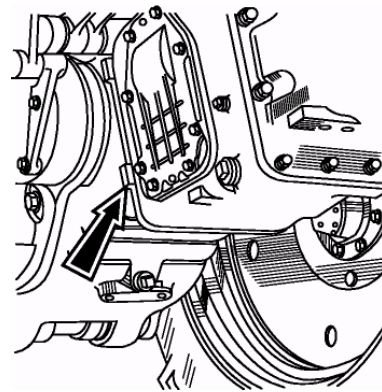

FDA number (on the right-hand sleeve at the front of the FDA (822) or on the central housing at the front of the FDA (72)).

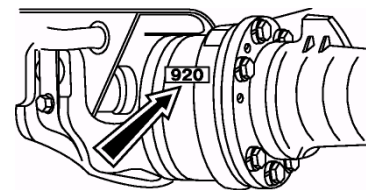
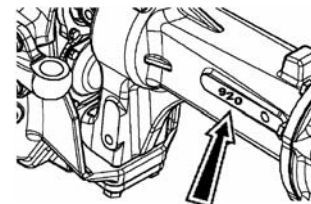

Cab serial number and OECD certificate number (inside the cab on the left).

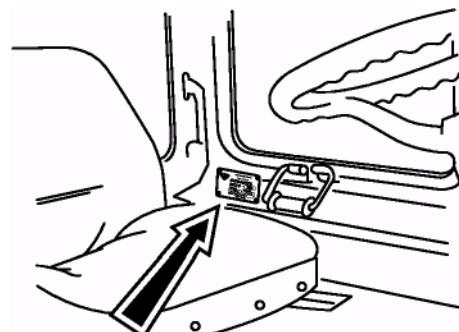

Engine

Engine make	Д-243/243С	Д-245.5/Д-245.5С	Д-245.43 S2	Д-245.5 S2
Type	Four-stroke, in-line, naturally aspirated	Four-stroke, in-line, turbocharged	Four-stroke, in-line, turbocharged, with intermediate charge air cooling	Four-stroke, in-line, turbocharged, with intermediate charge air cooling
Number of cylinders	4			
Method of mixing	Direct injection			
Compression (calculated)	16	15.1	15.1	15.1
Bore, mm	110			
Stroke, mm	125			
Displacement, l	4.75			
Order	1-3-4-2			
Cooling system	Liquid			
Rated speed, rpm	2200	1800	1800	1800
Max speed, rpm	2380	1980	2050	2070
Min speed, rpm	600	700	800	800
Rated power, kW (H.P.)	60 (81) at 2200 rpm	65 (89) at 1800 rpm	62 (83.7) at 1800 rpm	70 (94.5) at 1800 rpm
Max torque N·m	296.9 at 1400 rpm	386 at 1400 rpm	411 at 1400 rpm	464 at 1400 rpm
Clearance between intake and exhaust valves and rockers at idle running, mm	0.25...0.30	0.25...0.30 – for intake valves, 0.40...0.45 – for exhaust valves	0.20...0.30 – for intake valves, 0.35...0.50 – for exhaust valves	0.20...0.30 – for intake valves, 0.35...0.50 – for exhaust valves
Advance angle of fuel injection before upper dead point (UDP), degrees	20±1/16±1	18±1/13±1 or 9±1	4.0±0.5	4.0±0.5
Fuel injection pressure, MPa	21.6...22.4	21.6...22.4	23.5...24.7	23.5...24.7

Diesel engine lubrication system

Type: combined, with oil radiator (or LOHE for tractors 900.3/920.3/950.3/952.3).

Min oil pressure:

0.08 MPa (0.8 kgf/cm²) at 600 rpm.

Normal oil pressure:

0.2...0.3 MPa (2...3 kgf/cm²).

Max pressure at cold diesel engine: up to 0.6 MPa (6 kgf/cm²).

Lubrication system capacity: 12 l.

Motor oil brands:

- from -40°C to +5°C: M-8ДМ; M-8Г₂, M-8Г_{2К} or M4₃/8Г₂ (SAE-20, SAE 10W-20);
- from +5°C to +50°C: M-10ДМ; M-10Г₂; M-10Г_{2К} (SAE-30);
- multigrade oil: SAE 15W-40.

Engine feed system

Fuel pump: 4-plunger pump, in-line, with boost pump.

Governor: mechanical, variable-speed (with antismoke pneumatic equalizer – for diesel engines Д-245.5/Д-245.5С/Д-245.5 S2/Д-245.43 S2).

Turbocharger: centripetal radial turbine on a shaft with centrifugal compressor (Д-245.5/ Д-245.5С/Д-245.5 S2/Д-245.43 S2).

Charge air cooler (for Д-245.5S2/Д-245.43S2): air-air type, mounted prior to water radiator.

Fuel filters: coarse filter and secondary filter (with removable paper filter element).

Fuel brand: Diesel: summer

Л-0.2-40, Л-0.5-40; winter 3-0.2, 3-0.5; at -50°C – А-0.2, А-0.4.

Fuel tank capacity: 130 l

(2 tanks); 120 l (one tank) for tractors with hydraulic lift.

Air cleaner: combined, with centrifugal and oil-bath air cleaning.

Air cleaner oil bath capacity: 1.5 l (3.0 l – for the Д-245.5 engine).

Donaldson dry-type air cleaner – for Д-245.5 S2/ Д-245.43 S2.

Engine starting system

Electric starter type, 12 V or 24 V.

Easy starting facilities:

- electric torch pre-heater (filament plug in the intake manifold) or filament plugs in diesel cylinder head (for the engines with the index “S2”).

Engine cooling system

Type: water, closed with forced liquid circulation, temperature controlled by the thermostatic regulator and a shutter from the driver's seat, with expansion tank (for Д-245.5 S2/Д-245.43 S2).

Normal operating temperature: from 80°C to 100°C.

Cooling system capacity: 20 l.

Steering control

Type: Hydrostatic power steering with steering cylinder in the steering linkage. Independent oil tank of HPS (for Belarus - 900.3/920.3/950.3/952.3).

Safety valve adjustment pressure – 14 MPa.

Shock valve adjustment pressure – 20 MPa.

Oil brands:

BECHEM Stariol №32;
ADDINAL Hydraulikol HLP 32;
THK Hydraulic HLP 32.

Feed pump capacity: 21 l/min (28 l/min)*

Hydraulic cylinder: two-way type,

- bore: 50 mm (63 mm)*
- stroke: 200 mm.

Metering pump: volumetric constant: 100 cm³/rev (160 cm³/rev)*, operating pressure: from 10 to 14 MPa. Installed at the front wall of the cab.

Steering wheel position control limits:

- by inclination: from 25° to 40° with fixation through 5°;
 - by height: – within the range of 100 mm.
- Steering wheel free play: not more

* For the FDA with planetary-cylindrical reducing gears (BELARUS-920.2/920.3/952.2/952.3)

than 25°.

Clutch

Type: friction, dry, single-disk, with tangential suspension of the pressure plate.

Driven disk diameter – 340 mm.

Gearbox

Type: 7/2, mechanical, stepwise, synchronized, dual-range.

I range (stage): 1st, 2nd and 3rd gear of forward motion and one gear of reverse.

II range (stage): 1st, 2nd, 3rd and 4th gears of forward motion and one of reverse.

ATTENTION! The 4th gear can be only engaged if the II range is selected.

Calculated speeds (km/h) of BELARUS 900 series tractors:

Rated engine rotational speed, rpm: 2200 Rear tyres: 16.9R38 Synchronized splitter			
Motion	Gear number	Range number	V tr, km/h
front	1	I	2.5
			3.4
			7.4
	9.8		
	8.7		
	11.6		
	2	II	4.3
			5.7
			12.6
			16.6
3		14.9	
		19.7	
4		27.7	
		36.6	
rear	1R	I	5.4
			7.1
	2R	II	9.1
			12.1

Rated engine rotational speed, rpm: 2200 Rear tyres: 18.4R34 Synchronized splitter			
Motion	Gear number	Gear number	V tr, km/h
front	1	I	2.5
			3.2
			7.1
	9.4		
	8.4		
	11.1		
	2	II	4.2
			5.5
			12.1
			16.0
3		14.3	
		18.9	
4		26.6	
		35.2	
rear	1R		5.2
			6.8
	2R	II	8.8
			11.6

Rated engine rotational speed, rpm: 1800 Rear tyres: 16.9R38 Synchronized multiplier			
Motion	Gear number	Range number	V tr, km/h
front	1	I	2.8
			3.6
			8.0
	10.6		
	9.5		
	12.5		
	2	II	4.7
			6.2
			13.6
			18.0
	16.1		
	21.3		
3	II	29.9	
		39.6	
rear	1R	I	5.8
			7.7
	2R	II	9.9
			13.1

Rated engine rotational speed, rpm: 1800 Rear tyres: 18.4R34 Synchronized splitter			
Motion	Gear number	Range number	V tr, km/h
front	1	I	2.0
			2.7
			5.8
	7.7		
	6.9		
	9.1		
	2	II	3.4
			4.5
			9.9
			13.1
	11.7		
	15.5		
3	II	21.8	
		28.8	
rear	1R	I	4.2
			5.6
	2R	II	7.2
			9.5

Rated engine rotational speed, rpm: 1800 Rear tyres: 18.4R34 Synchronized multiplier			
Motion	Gear number	Range number	V tr, km/h
front	1	I	2.7
			3.5
			7.7
	10.2		
	9.1		
	12.0		
	2	II	4.5
			6.0
			13.1
			17.3
	15.5		
	20.5		
3	II	28.8	
		38.1	
rear	1R	I	5.6
			7.4
	2R	II	9.5
			12.6

Rated engine rotational speed, rpm: 1800 Rear tyres: 16.9R38 Synchronized splitter			
Motion	Gear number	Range number	V tr, km/h
front	1	I	2.1
			2.8
			6.0
	8.0		
	7.1		
	9.4533		
	2	II	3.5
			4.7
			10.3
			13.6
	12.2		
	16.1		
3	II	22.6	
		29.9	
rear	1R	I	4.4
			5.8
	2R	II	7.5
			9.9

Rated engine rotational speed, rpm: 1800 Rear tyres: 16.9R38 Reverse gear			
Motion	Gear number	Range number	V tr, km/h
front	1	I	2.8
		II	4.7
	2	I	8.0
		II	13.6
	3	I	9.5
		II	16.1
	4		29.9
rear	1	I	2.6
		II	4.4
	2	I	7.5
		II	12.7
	3	I	8.8
		II	15.0

Rated engine rotational speed, rpm: 1800 Rear tyres: 18.4R34 Reverse gear			
Motion	Gear number	Range number	V tr, km/h
front	1	I	2.7
		II	4.5
	2	I	7.7
		II	13.1
	3	I	9.1
		II	15.5
	4		28.8
rear	1	I	2.5
		II	4.2
	2	I	7.2
		II	12.2
	3	I	8.5
		II	14.5

Rated engine rotational speed, rpm: 2200 Rear tyres: 16.9R38 Reverse gear			
Motion	Gear number	Range number	V tr, km/h
front	1	I	3.4
		II	5.7
	2	I	9.8
		II	16.6
	3	I	11.6
		II	19.7
	4		36.6
rear	1	I	3.1
		II	5.4
	2	I	9.1
		II	15.6
	3	I	10.8
		II	18.7

Rated engine rotational speed, rpm: 2200 Rear tyres: 18.4R34 Reverse gear			
Motion	Gear number	Range number	V tr, km/h
front	1	I	3.2428
		II	5.5215
	2	I	9.3909
		II	15.9898
	3	I	11.1207
		II	18.9353
	4		35.2157
rear	1	I	3.0266
		II	5.1534
	2	I	8.7648
		II	14.9238
	3	I	10.3794
		II	17.6730

ATTENTION! Simultaneous engagement of the 4th forward gear and reverse gear is excluded by the design to avoid high reverse speeds of the tractor.

Calculated speeds (km/h) of the BELARUS tractors of the series 900 with a speed-reducing unit:

Rated engine rotational speed, rpm: **1800**

Rear tyres: **18.4R34**

Synchronized splitter

Gear No.	Range No.	V tr, km/h	V tr with a mechanical speed-reducing unit, km/h				V tr with a hydraulic speed-reducing unit, km/h			
			Mechanical speed-reducing unit range I		Mechanical speed-reducing unit range II		Hydraulic speed-reducing unit range I		Hydraulic speed-reducing unit range II	
			1st gear of the mechanical speed-reducing unit	2nd gear of the mechanical speed-reducing unit	1st gear of the mechanical speed-reducing unit	2nd gear of the mechanical speed-reducing unit	1st gear of the hydraulic speed-reducing unit	2nd gear of the hydraulic speed-reducing unit	1st gear of the hydraulic speed-reducing unit	2nd gear of the hydraulic speed-reducing unit
		4.28	1.44	1.03	0.34	4.28	1.44	1.03	0.3	
1	I	2.0	0.47	1.4	2.0	5.9	0... 0.5	0.8... 1.4	2.0	6.0
		2.7	0.6	1.8	2.6	7.8	0.12... 0.6	1.2... 1.8	2.6	7.9
2	I	5.8								
		7.7								
3	I	6.9								
		9.1								
1	II	3.4	0.8	2.4	3.3	10.0	0.3... 0.8	1.7... 2.4	3.34	10.0
		4.5	1.1	3.1	4.4	13.3	0.5... 1.1	2.3... 3.1	4.4	13.3
2	II	9.9								
		13.1								
3	II	11.7								
		15.5								
4	II	21.8								
		28.8								
1R	I	4.2	1.0	3.0	4.1	12.4	0... 1.0	0... 3.0	4.1	12.4
		5.6	1.3	3.9	5.4	16.4	0.3... 1.3	0.3... 3.9	5.4	16.4
2R	II	7.2	1.7	5.0	7.0		0.6... 1.7	0.6... 5.0	7.0	
		9.5	2.2	6.6	9.2		1.1... 2.3	1.1... 6.7	9.2	

Rated engine rotational speed, rpm: **2200**

Rear tyres: **18.4R34**

Synchronized splitter

Gear No.	Range No.	V tr, km/h	V tr with a mechanical speed-reducing unit, km/h				V tr with a hydraulic speed-reducing unit, km/h					
			Mechanical speed-reducing unit range I		Mechanical speed-reducing unit range II		Hydraulic speed-reducing unit range I				Hydraulic speed-reducing unit range II	
			1st gear of the mechanical speed-reducing unit	2nd gear of the mechanical speed-reducing unit	1st gear of the mechanical speed-reducing unit	2nd gear of the mechanical speed-reducing unit	1st gear of the hydraulic speed-reducing unit		2nd gear of the hydraulic speed-reducing unit		1st gear of the hydraulic speed-reducing unit	2nd gear of the hydraulic speed-reducing unit
			4.28	1.44	1.03	0.34	4.28		1.44		1.03	0.3
1	I	2.5	0.6	1.7	2.4	7.2	0... 0.6	0.8... 1.7	2.4	7.2		
		3.2	0.8	2.3	3.1	9.5	0.1... 0.8	1.2... 2.39	3.1	9.5		
2	I	7.1										
		9.34										
3	I	8.4										
		11.1										
1	II	4.2	1.0	2.9	4.1	12.3	0.3... 1.0	1.7... 2.9	4.1	12.3		
		5.5	1.3	3.8	5.4	16.2	0.5... 1.3	2.3... 3.8	5.4	16.2		
2	II	12.1										
		16.0										
3	II	14.3										
		19.0										
4	II	26.6										
		35.2										
1R	I	5.2	1.2	3.6	5.0	15.2	0... 1.24	0... 3.6	5.0	15.2		
		6.8	1.6	4.7	6.6	20.1	0.3... 1.6	0.3... 4.7	6.6	20.1		
2R	II	8.8	2.1	6.1	8.5		0.6... 2.06	0.6... 6.1	8.5			
		11.6	2.7	8.1	11.3		1.1... 2.7	1.1... 8.1	11.3			

Rated engine rotational speed, rpm: **1800**

Rear tyres: **16.9R38**

Synchronized splitter

Gear No.	Range No.	V tr, km/h	V tr with a mechanical speed-reducing unit, km/h				V tr with a hydraulic speed-reducing unit, km/h					
			Mechanical speed-reducing unit range I		Mechanical speed-reducing unit range II		Hydraulic speed-reducing unit range I		Hydraulic speed-reducing unit range II			
			1st gear of the mechanical speed-reducing unit	2nd gear of the mechanical speed-reducing unit	1st gear of the mechanical speed-reducing unit	2nd gear of the mechanical speed-reducing unit	1st gear of the hydraulic speed-reducing unit	2nd gear of the hydraulic speed-reducing unit	1st gear of the hydraulic speed-reducing unit	2nd gear of the hydraulic speed-reducing unit		
			4.28	1.44	1.03	0.34	4.28	1.44	1.03	0.3		
1	I	2.1	0.5	1.4	2.0	6.1	0... 0.5	0.8... 1.4	2.0	6.1		
		2.8	0.6	1.9	2.7		0.1... 0.6	1.2... 1.9	2.7	8.1		
2		6.0										
		8.0										
3		7.1										
		9.5										
1	II	3.5	0.8	2.5	3.4	10.4	0.3... 0.8	1.7... 2.5	3.4	10.4		
		4.7	1.1	3.3	4.6	13.8	0.5... 1.1	2.3... 3.26	4.6	13.8		
2		10.3										
		13.6										
3		12.2										
		16.1										
4		22.6										
		30.0										
1R	I	4.4	1.0	3.0	4.3	12.9	0... 1.0	0... 3.0	4.3	13.0		
		5.8	1.4	4.0	5.6	17.1	0.3... 1.4	0.3... 4.0	5.6	17.1		
2R	II	7.5	1.7	5.2	7.3		0.6... 1.7	0.6... 5.2	7.3			
		9.9	2.3	6.9	9.6		1.1... 2.3	1.1... 6.9	9.6			

Rated engine rotational speed, rpm: **2200**

Rear tyres: **16.9R38**

Synchronized splitter

Gear No.	Range No.	V tr, km/h	V tr, with a mechanical speed-reducing unit, km/h				V tr with a hydraulic speed-reducing unit, km/h					
			Mechanical speed-reducing unit range I		Mechanical speed-reducing unit range II		Hydraulic speed-reducing unit range I		Hydraulic speed-reducing unit range II			
			1st gear of the mechanical speed-reducing unit	2nd gear of the mechanical speed-reducing unit	1st gear of the mechanical speed-reducing unit	2nd gear of the mechanical speed-reducing unit	1st gear of the hydraulic speed-reducing unit	2nd gear of the hydraulic speed-reducing unit	1st gear of the hydraulic speed-reducing unit	2nd gear of the hydraulic speed-reducing unit		
			4.28	1.44	1.03	0.34	4.28	1.44	1.03	0.3		
1	I	2.5	0.6	1.8	2.5	7.5	0... 0.6	0.8... 1.8	2.5	7.5		
		3.4	0.8	2.3	3.3	10.0	0.1... 0.8	1.2... 2.3	3.3	9.9		
2	I	7.4										
		9.8										
3	I	8.7										
		11.6										
1	II	4.3	1.0	3.0	4.2	12.8	0.3... 1.0	1.7... 3.0	4.2	12.8		
		5.7	1.3	4.0	5.6	16.9	0.5... 1.3	2.3... 4.0	5.6	16.9		
2	II	12.6										
		16.6										
3	II	14.9										
		19.7										
4	II	27.7										
		36.6										
1R	I	5.4	1.3	3.7	5.2	15.8	0... 1.3	0... 3.7	5.2	15.8		
		7.1	1.7	5.0	6.9	20.9	0.3... 1.7	0.3... 5.0	6.9	20.9		
2R	II	9.1	2.1	6.3	8.9		0.6... 2.1	0.6... 6.3	8.9			
		12.1	2.8	8.4	11.7		1.1... 2.82	1.1... 8.4	11.7			

Rated engine rotational speed, rpm: **1800**Rear tyres: **16.9R38****Reverse gear**

Motion	Gear No.	Range No.	V tr, km/h	V tr, with a mechanical speed-reducing unit, km/h			
				Mechanical speed-reducing unit range I		Mechanical speed-reducing unit range II	
				1st gear of the mechanical speed-reducing unit	2nd gear of the mechanical speed-reducing unit	1st gear of the mechanical speed-reducing unit	2nd gear of the mechanical speed-reducing unit
				4.28	1.44	1.03	0.34
front	1	I	2.8	0.6	2.0	2.7	8.1
		II	4.7	1.1	3.3	4.6	13.8
	2	I	8.0				
		II	13.6				
	3	I	9.5				
		II	16.11				
	4		30.0				
	rear	1	I	2.6	0.6	1.8	2.5
II			4.4	1.0	3.0	4.3	12.9
2		I	7.5				
		II	12.7				
3		I	8.8				
		II	15.0				
4							

Rated engine rotational speed, rpm: **2200**Rear tyres: **16.9R38****Reverse gear**

Motion	Gear No.	Range No.	V tr, km/h	V tr, with a mechanical speed-reducing unit, km/h			
				Mechanical speed-reducing unit range I		Mechanical speed-reducing unit range II	
				1st gear of the mechanical speed-reducing unit	2nd gear of the mechanical speed-reducing unit	1st gear of the mechanical speed-reducing unit	2nd gear of the mechanical speed-reducing unit
				4.28	1.44	1.03	0.34
front	1	I	3.4	0.8	2.3	3.3	10.0
		II	5.7	1.3	4.0	5.6	16.9
	2	I	9.8				
		II	16.6				
	3	I	11.6				
		II	19.7				
	4		36.6				
	rear	1	I	3.1	0.7	2.2	3.1
II			5.4	1.3	3.7	5.2	15.7
2		I	9.1				
		II	15.5				
3		I	10.8				
		II	18.4				
4							

Rated engine rotational speed, rpm: **1800**Rear tyres: **18.4R34****Reverse gear**

Motion	Gear No.	Range No.	V tr, km/h	V tr, with a mechanical speed-reducing unit, km/h			
				Mechanical speed-reducing unit range I		Mechanical speed-reducing unit range II	
				1st gear of the mechanical speed-reducing unit	2nd gear of the mechanical speed-reducing unit	1st gear of the mechanical speed-reducing unit	2nd gear of the mechanical speed-reducing unit
front	1	I	2.7	4.28	1.44	1.03	0.34
		II	4.5	0.6	1.8	2.6	7.8
	2	I	7.7	1.1	3.1	4.4	13.3
		II	13.1				
	3	I	9.1				
		II	15.5				
	4		28.8				
	rear	1	I	2.5	0.6	1.75	2.4
II			4.2	1.0	2.9	4.1	12.4
2		I	7.2				
		II	12.2				
3		I	8.5				
		II	14.5				
4							

Rated engine rotational speed, rpm: **2200**Rear tyres: **18.4R34****Reverse gear**

Motion	Gear No.	Range No.	V tr, km/h	V tr, with a mechanical speed-reducing unit, km/h			
				Mechanical speed-reducing unit range I		Mechanical speed-reducing unit range II	
				1st gear of the mechanical speed-reducing unit	2nd gear of the mechanical speed-reducing unit	1st gear of the mechanical speed-reducing unit	2nd gear of the mechanical speed-reducing unit
front	1	I	3.2	4.28	1.44	1.03	0.34
		II	5.5	0.8	2.6	3.1	9.5
	2	I	9.4	1.3	3.8	5.4	16.2
		II	16.0				
	3	I	11.1				
		II	19.0				
	4		35.2				
	rear	1	I	3.0	0.7	2.1	3.0
II			5.2	1.2	3.61	5.0	15.2
2		I	8.8				
		II	15.0				
3		I	10.4				
		II	17.7				
4							

Synchronized splitter (reducing gear)

Type: mechanical, synchronized, with direct drive and retarding gear. Located between the clutch and gearbox and controlled by the lever under the steering column. Allows reducing speed at each gear 1.32 times and obtaining 14 forward gears and 4 reverse gears.

Synchronized multiplier

Type: mechanical, synchronized, with direct drive and multiplying gear. Located between the clutch and gearbox and allows increasing speed at each gear 1.32 times.

Reverse gear (optional)

Type: mechanical, synchronized, with

forward motion and reverse ($i=-1.07$ or $i=-1.88$). Installed instead of step-down reducing gear and allows obtaining 9 forward gears and 8 reverse ones.

Speed-reducing unit (optional)

Type: mechanical, two-range, two-speed. It allows super low speeds to be obtained. Installed instead of left cover of the gearbox and allows obtaining additionally 16 forward gears and 16 reverse ones.

Important! When using the speed-reducing unit, engage only the 1st gear in the gearbox and the 1st reverse gear (I-I and I-R).

Rear axle

Main gear: a pair of bevel gears with circular sprocket teeth.

Final drive: a pair of cylindrical gears.

Differential: conical, four-satellite type.

Differential lock mechanism: hydraulic, dry, friction coupling or multi-disk friction coupling of "wet" type (optional).

Brakes

Service: rear wheels: dry two- and three-disk type with mechanical servo drive. Disk diameter: 204 mm (or 8-disk type operating in an oil bath (optional))

Parking: dry disk-type with mechanical manual drive. Disk diameter: 180 mm (or 4-disk type operating in an oil bath (optional)).

Front driving axle

Type: portal, with sliding housings of bevel reducing gears (Belarus-920/952) or portal, with non-sliding bar, with planetary reducing gears (Belarus-920.2/952.2/920.3/952.3)

Main gear: bevel gears with auger teeth.

Differential type: self-locking, of higher friction.

Final drive: wheel reduction gears with straight bevel pairs (Belarus-920.2/952.2/920.3/952.3).

Transmission oils: Тар-15В, ТСп-15К or ТСп-10 (SAE 80W-90); ТАД-17И.

Drive: from transfer gear by two cardan shafts with intermediate support.

FDA control: mechanical, by the lever for operator's right hand.

3 operating modes:

FDA is DISENGAGED;

FDA is ENGAGED forcedly;

FDA is ENGAGED/DISENGAGED automatically.

Power take-off shaft (PTO) drive

Type: independent two-speed and synchronous.

Master clutch: planetary reducing gear with band brakes.

PTO control: mechanical (electro-hydraulic – for tractors with a hydraulic lift) by means of the lever at the right-

side control board.

PTO coupler shank speed:

Independent drive:

- 540 rpm at 2081 rpm of the diesel engine (Belarus-900/920);
- 540 rpm at 1632 rpm of the diesel engine (Belarus-950/952);
- 1000 rpm at 2302 rpm of the diesel engine (Belarus-900/920)
- 1000 rpm at 1672 rpm of the diesel engine (Belarus-950/952)

Synchronous drive: 4.76 revolutions/metre of travel with the rear tyres 16,9R38 mounted.

Removable PTO coupler shank: in accordance with the SAE standard with 6 splines for 540 rpm and 21 splines for 1000 rpm.

Rotation: clockwise as seen from the shaft butt.

Hydraulic system

Type: universal, unit-principal, with independent power cylinder (Belarus-900/920/950/952) or with hydraulic lift, with two self-contained cylinders (Belarus-900.3/920.2/920.3/950.3/952.2/952.3).

Maximum pressure in the hydraulic system: 18...20 MPa.

Distributor: spool valve type:

- P80-3/4-222-3Гr (P80-3/4-111-3Гr optional);
- P70-1221C; RS213 Belarus — for tractors with power governor;
- ПП70-1221; RS213 Mita flow-type — for tractors with hydraulic lift.

Hydraulic system outlets: two side and one rear outlets (drain one – optional).

RMA control system has three operating modes:

- power;
- position;
- high-altitude.

Hydraulic system oil brands:

BECHEM Stariol №32;

ADDINAL Hydraulikol HLP 32;

THK Hydraulic HLP32.

Rear mounted attachment

Type: three-point mounted system of

category 2

Lifting capacity: 3000 kg at the ends of longitudinal rods

Electrical equipment

Voltage: 12 V.

Start system voltage: 12 V or 24 V.

Power supply system: two storage batteries, 12 V each, connected in parallel (series connection when starting the engine for supplying the starter with the voltage of 24 V).

Alternator

14 V, 1000 W (1150 W – for Belarus-900.3/920.3/950.3/952.3).

Lighting system and light alarm:

- front headlights with lower and distance light;
- front and rear work lights;
- clearance and brake lights;
- dashboard, cab and number plate lighting;
- emergency warning lights;
- road-train sign.

Pneumatic system

Compressor

Type: single-cylinder, air-cooled.

Trailer brake control actuator

Type: pneumatic, single-ended, inter-

locked with tractor brakes.

Twin actuator – for Belarus-900.3/920.3/950.3/952.3

Pressure restricted by safety valve: 0.65...0.80 MPa.

Wheels

Front:

9.00R20 or 9.0-20 (Belarus-900/900.3/950/950.3) main;
13.6-20 (Belarus-920/952) main;
11.2-20 (Belarus-920/952) optional;
360/70R24 (Belarus-920.2/920.3/952.2/952.3) main.

Rear:

16,9R38 (Belarus-920/952) main;
18,4R34 (Belarus- /920.3/952.2/952.3) main;
18,4R34 (Φ-11) (Belarus-900/900.3/920.2/950/950.3) main.

Other equipment

Front and rear wipers, cab heating and ventilation system, windshield washer, cab lighting dome, air conditioner (optional).

CONTROLS AND INSTRUMENTATION

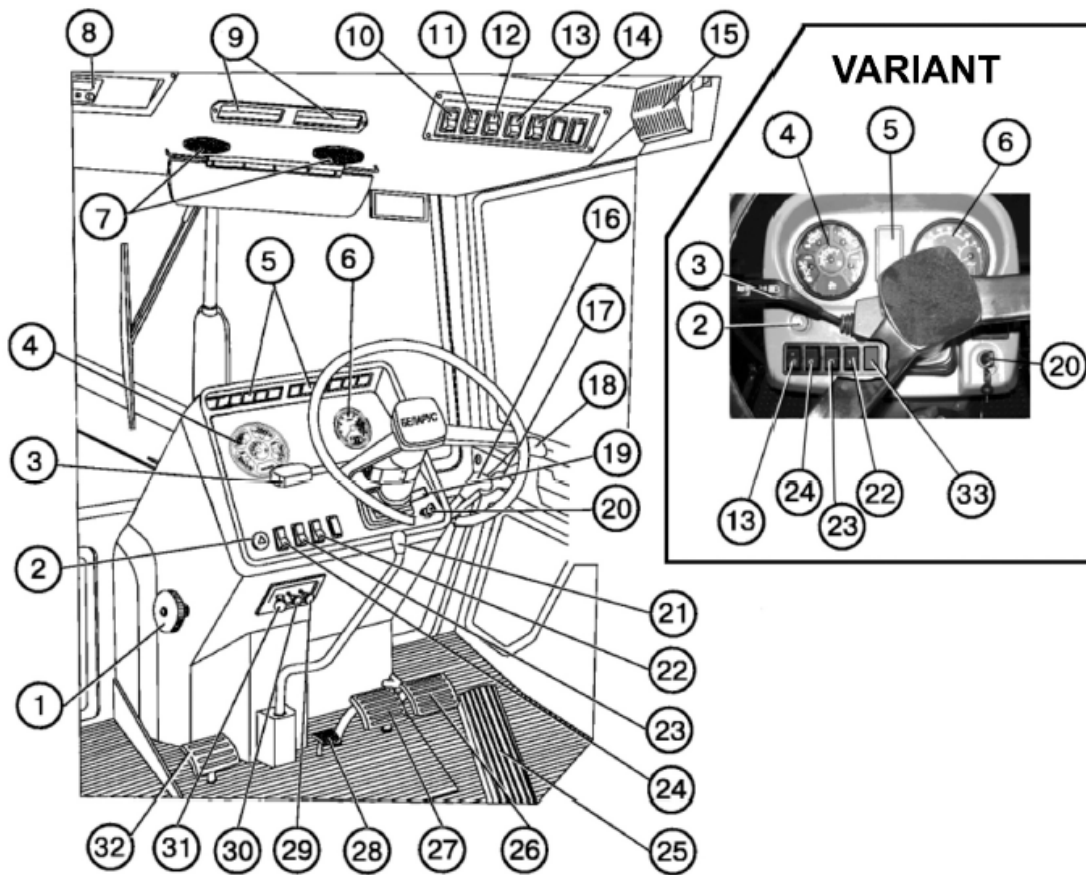

- | | |
|---|---|
| <ol style="list-style-type: none"> 1. Cooling system radiator shutter control. 2. Emergency control lamps switch. 3. Steering-wheel-mounted multifunction switch (turn, turn indicators, upper/lower beam). 4. Combination meter. 5. Control lamps block. 6. Electric tachospeedometer. 7. Air distributors. 8. Radio receiver (if installed). 9. Recirculation shutters. 10. Windscreen wiper switch. 11. Cab fan and heater switch. 12. Rear working lights switch. 13. Front working lights switch. 14. Road-train sign lighting switch. 15. Cab light switch. 16. Control of the left-side outputs of the hydraulic system. 17. Control of the right-side outputs of the hydraulic system. | <ol style="list-style-type: none"> 18. Control of the left rear outputs of the hydraulic system. 19. Tachospeedometer control board. 20. Starter and instrumentation switch. 21. Control of the step-down reduction gear and shuttle gear (if installed). 22. Starting aid switch (for tractors equipped with an electric torch pre-heater). 23. Windscreen washer switch. 24. Clearance lights and headlights switch. 25. Fuel feed control pedal. 26. Right service brake pedal. 27. Left service brake pedal. 28. Rear axle differential lock control. 29. Steering column inclination control. 30. Engine shutdown cord handle 31. Cab heater valve control (if installed). 32. Clutch pedal. 33. Plug. |
|---|---|

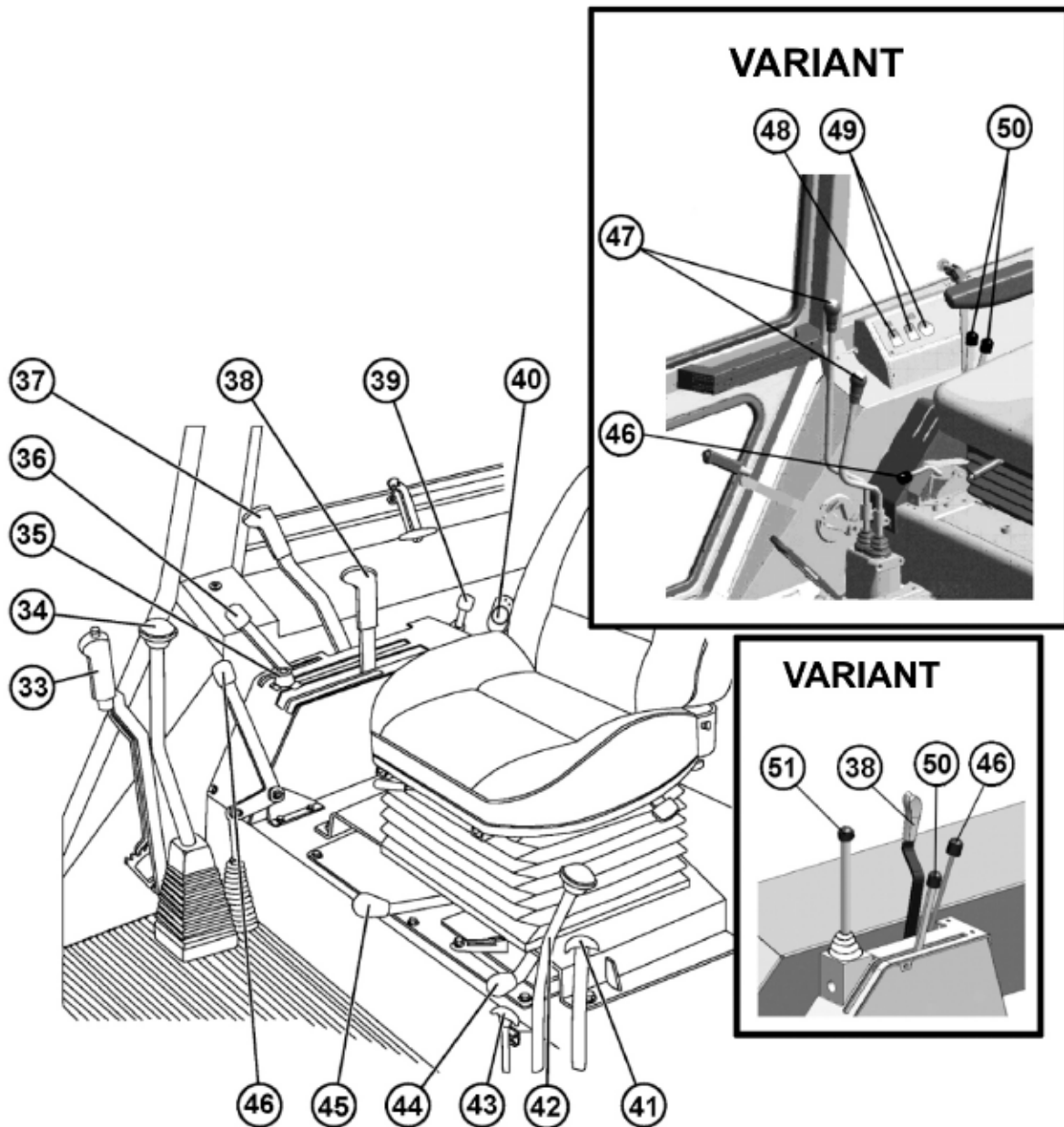

- 33. Parking brake lever.
- 34. Gearbox control lever.
- 35. Stop bumper of power governor control lever.
- 36. Fuel feed control arm.
- 37. PTO control lever.
- 38. Power governor control arm.
- 39. Signal switch arm of power and position control sensors (if installed).
- 40. SB switch (on the BELARUS-900.3/920.3/950.3/952.3 tractors, the SB switch is located under the bonnet in the SB zone)

- 41. Speed-reducer gear switch arm (if installed).
- 42. Speed-reducer gear range switch arm (if installed).
- 43. Control handle of the hydraulic hook claws.
- 44. PTO switch arm (independent/synchronized).
- 45. Arm for fixing the hinging mechanism in the lifted position (version with a power governor).
- 46. FDA drive control arm.
- 47. Gearbox control levers.
- 48. Rear axle differential lock control
- 49. PTO control
- 50. Hydraulic hoist control levers
- 51. Joy stick for remote control of the hydraulic system distributor (if installed)

IMPORTANT! Prior to working on the tractor, study the controls and instrumentation and their functions.

Instrumentation and Switches

Starter and instrumentation switch (1)

Switch (1) has four positions:

- 0 – “Off”
- I – “Consuming units On”
- II – “Starter On” (not fixed)
- III – “Radio receiver ON” (key turned counter-clockwise)

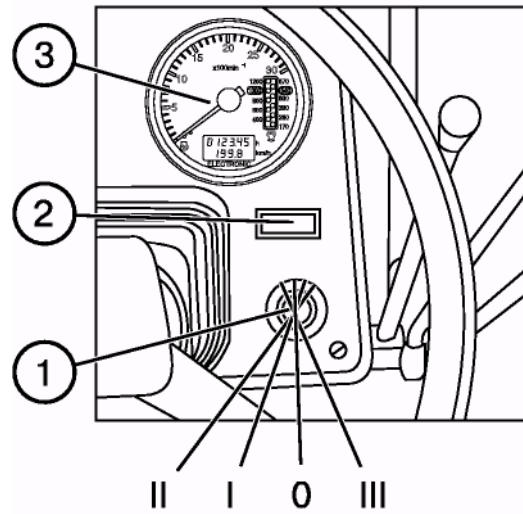

1. Instrumentation

The schematics of the instrument dashboards 80-3805010-Д1 and 826-3805010 are given in the section “Appendix”.

The instrumentation includes:

- the combination meter (P2) with sensors;
- the electric tachospeedometer (P1) with the control board (A3) and sensors;
- the electric light and audible alarms combined into two pilot lamp units (HG1 and HG2) in the instrument dashboard 80-3805010-Д1 or into the pilot lamp unit and combination meter in the instrument dashboard 826-3805010.

To switch on the instruments, turn the starter and instrumentation switch to the “I” position. Then the voltage will be applied to the terminal “K3” of the switch, then to the relay for power supply of the instruments, to the fuse (F2) of the unit and further – to the units (HG1 and HG2), tachospeedometer (P1), alarm device (HA2), combination meter (P1) and speed sensors (BV1 and BV2).

The instrument pointers shall move to the zero position or to the position corresponding to the true value of the parameter controlled by the system at the moment.

In case of deviation of readings of the instruments from their true values, detect the cause of the fault following the recommendations below.

1.1. Tachospeedometer AP70.3813 (Fig. 1)

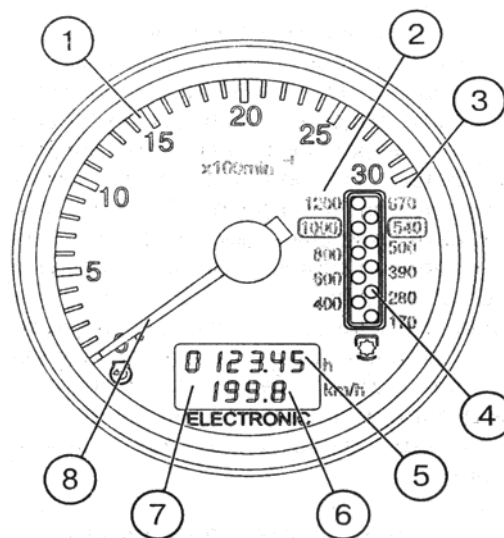

Fig. 1. Tachospeedometer (P1):

1. Engine crankshaft rotational speed scale, rpm.
2. PTO II rotational speed scale –1000 rpm.
3. PTO I rotational speed scale –540 rpm.
4. PTO rotational speed display (LED).
5. Engine running hours indication, h.
6. Tractor speed indication, km/h.
7. Display of engine running hours and tractor speed, km/h.
8. Pointer indicator of the engine crankshaft speed (LCD).

The electric tachospeedometer AP703813 installed in the dashboard operates as follows:

- On setting the starter and instrument switch is put to position I when the tractor is stopped, the display (7) shows the engine running hours (5);

- When the tractor is moving, the display (7) shows the tractor speed indication (6) (km/h), while the indication (5) disappears. The electric signal of the speed comes from the speed sensors mounted on the rear axle cover (BV1, BV2). The speed readings are taken through a signal from the sensor mounted on the pinion of the final drive of the wheel rotating at lesser speed. The calculated speed is higher than the actual one, because no tractor skid is taken into account;
- On starting the engine, the pointer indicator (8) moves round the index dial (1) to display the rotational speed of the engine crankshaft. At the same time, the display (4) shows the PTO indication (rpm). The scale (3) is assigned to the PTO I and the scale (2) – to the PTO II. The electric signal of the rotational speed is taken from the phase winding of the alternator.

1.2. Tachospeedometer control board (Fig. 2)

The control board is installed in the dashboard and serves for programming the tachospeedometer to the specific model of the Belarus tractor.

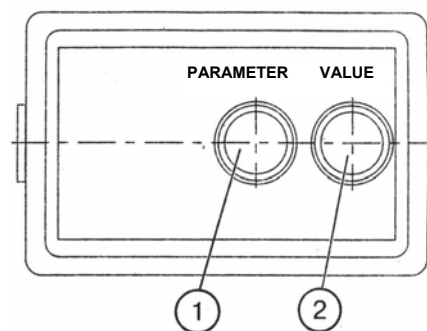

Fig. 2. Control board (A3):

1 – Button for setting the tachospeedometer to the programming mode and selecting the programming parameter on the tachospeedometer display (7). 2 – Button for selecting the value of the coded parameter shown on the display (7)

1.3. Programming the tachospeedometer AP70.3813

ATTENTION! The tachospeedometer has been programmed just to your tractor make at the factory. Re-programming is required in case of tyre type changing. Do not re-program the tachospeedometer, if unnecessary.

The tachospeedometer shall be programmed to ensure the correct display of the following tractor's parameters: engine rotational speed, tractor motion speed and PTO rotational speed (540 and 1000 rpm).

Programming procedure:

- Remove the control board cover;
 - Press the button (1) to enter the programming mode (Fig. 2).
1. To ensure the correct display of the tractor motion speed, it is necessary to program the tachospeedometer to the number of teeth of the pinion at the place of installation of the speed sensors (parameter "Z") and rear wheel rolling radius (parameter "R"). To do this:
 - press the button (1) of the board and call the parameters "Z" and "R" in turn to the display (3) of the tachospeedometer (4);
 - press the button (2) of the board and set the number of teeth (Z) according to Table 1 and value Rk according to Table 2:

Table 1

Number of teeth (Z)	Tractor make
69	Belarus 590; 80.1; 890; 900; 922; 950

Table 2

Tyre mark	16,9R30	18,4L30	15,5R38	9,5-42	18,4R34 (Φ-11)	16,9R38	18,4R38
Rk, m	0.698	0.720	0.755	0.730	0.770	0.800	0.830
Number coded	700	720	755	730	770	800	830

3. To ensure the correct display of the engine and PTO rotational speeds (540 and 1000), program the engine make (parameter "D"):

- press the button (1) and call the parameter "D" to the tachospeedometer display (3);
- press the button (3) and set the necessary engine make according to Table 3:

Table 3

Engine make	Д-243	Д-244	Д-245	Д-245.5
Rated rotational speed, rpm	2200	1700	2200	1800
Number programmed	243	244	245	245.5

On the expiry of seven seconds after programming, the instrument returns automatically to the operating mode. Refit the board cover.

Note: If no information on the type of the tyre fitted is available, it is allowed to measure the value Rk as a distance from the wheel axis to the ground prior to beginning the operation of the tractor.

1.4. Connecting the tachospeedometer

To connect the tachospeedometer to the instrumentation system, a 9-contact block is provided on the rear panel of the instrument (Fig. 3).

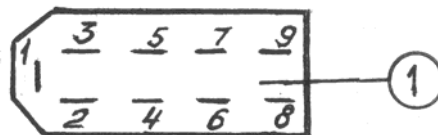

Fig. 3

The identification of the block pins is given in Table 4.

Table 4

Pin	Identification
1	to the terminal “-“
2	to the power supply unit “+12B”
3	to the board output “Parameter selection”
4	to the board output “Parameter value”
5	to the board output “Mode”
6	to the speed sensor BV2 (left wheel)
7	to the speed sensor BV1 (right wheel)
8	to the phase winding “W” of the alternator
9	to the instrument backlight lamps

1.5. Tachospeedometer diagnostics and troubleshooting

1. No instrument backlight:

Check the power supply wire connected to the pin “9” of the 9-contact block of the instrument (Fig. 3) – check if the backlight lamps are intact.

2. Jerking and jumps of the pointer of the engine rotational speed indicator over the dial: poor contact on the alternator terminal and, therefore, poor signal from the phase winding of the alternator. Repair.

3. Jerking of the pointer and understating the reading of the engine rotational speed:

- Check and adjust the tension of the alternator driving belt.

4. Over- or understated readings of the engine and PTO’s rotational speeds (with the normal movement of the pointer):

- Check the correctness of programming the instrument according to the engine make (parameter “D”): (see item 1.3);

5. The counter of astronomical hours of the engine running fails to accumulate the operating time: Check the connection of the wire to the contact “8” of the instrument block and the presence of the frequency signal from the phase winding of the alternator.

6. Over- or understated readings of the tractor speed:

- Check the correctness of the instrument programming according to the rolling radius of the rear wheels (Rk) (see item 1.3);

- Check the correctness of the programming according to the number of teeth of the half-axle pinion (Z) (see item 1.3).

7. No readings of the tractor motion speed: Check the presence of signals from both the speed sensors (BV1, BV2).

8. The readings “02...07” km/h appear on the instrument indicator when the tractor is moving:

- the numbers “02...07” and, 12 seconds later, “0” appear from the right side of the scale – no signal from the right speed sensor (BV1).

- the numbers “02...07” and then “0” appear from the left side of the scale – no signal from the left speed sensor (BV2).

1.6. Combined indicator КД 8083

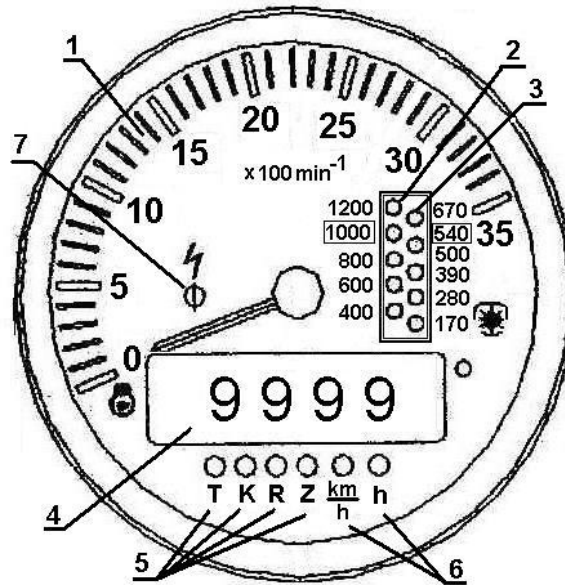

Fig. 4. Tachospeedometer (P1):

- 1 – Engine rotational speed indicator (pointer indicator).
- 2 – PTO 1000 rotational speed scale (opposite to the respective value of the PTO rotational speed).
- 3 – PTO 540 rotational speed scale (opposite to the respective value of the PTO rotational speed).
- 4 – Five-digit indicator.
- 5 – LED's lighting up in the mode of programming the coefficients "K", "R" and "Z" (opposite to the respective LED).
- 6 – LED's lighting up in the mode of display of the motion speed "km/h" and total engine running time "h" (opposite to the respective LED).
- 7 – Alarm of the overvoltage in the tractor on-board power system (red) operates, if the voltage exceeds 18.5 V.

In this case the instrument is switched off because the protective device operates. Should the voltage drop down to 16.5 V, the indicator returns to the operating state and the overvoltage indicator goes out.

Indicator operating procedure

On switching on the power supply, the indicator is switched to the main operating mode. In case of absence of signals from the speed sensors the digital indicator (4) shows the reading of the total engine running time and the LED located next to the symbol "h" lights up.

Total engine running time:



Appearance of the pulses from the speed sensors at the input of the pulse indicator causes the switching-on to the motion speed indication mode. Then the measured calculated speed reading is shown on the digital indicator and the LED located next to the symbol "km/h" lights up.

The calculated motion speed (km/h).



1.7. Programming the indicator КД8083

Programming procedure:

- remove the control board cover;
- press the button (1) of the control panel and hold it down for at least 2 seconds;
- the display (7) shows the mode "Adjusted total engine running time". In this case, the LED located next to the symbol "T" lights up.

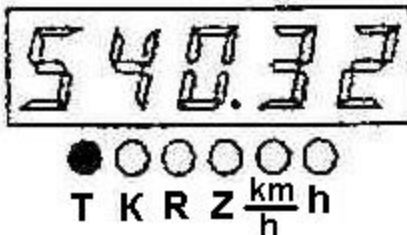

- press repeatedly the button (1) to switch over cyclically the programmable parameters;
- press the button "2" to enter the required value of the selected parameter, then the least significant digit (the first on the right) of the selected parameter of the indicator starts blinking with the period of 0.3 s;
- set the required value of the less significant digit of the selected parameter by pressing the button "2";
- press shortly the button "1"; then the second from the right digit of the digital indicator shall start blinking;
- set the required value in the second from the right digit of the parameter to be corrected by pressing the button "2";
- press shortly the button "1"; then the third from the right digit of the digital indicator shall start blinking;
- set the required value in the third from the right digit of the parameter to be corrected by pressing the button "2";
- fix the entered value of the parameter by pressing the button "1";
- on pressing the button "1" next time, the switching to the next parameter will occur.

To exit the programming mode, enter the adjusted time mode, press and hold down the button (2) for at least 2 s; then the readings "8.8.8.8" shall be shown in the five-digit indicator for 1-4 seconds and all the LEDs of the PTO's scales shall light up.

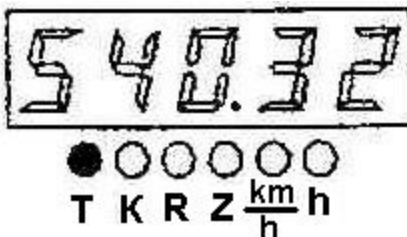

1. To display correctly the tractor motion speed, it is necessary to program the following parameters in the following order:
2. Gear ratio of the wheel reduction gear (parameter "K1") from Table 5:

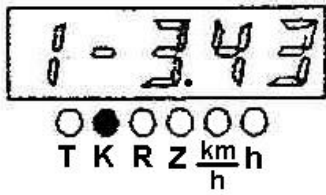

Table 5

Gear ratio of the wheel reduction gear (K1)	Tractor make
1.00	Belarus 590; 80.1; 890; 900; 922; 950

according to the number of teeth at the place of installation of the speed sensors (parameter "Z1") from Table 6:

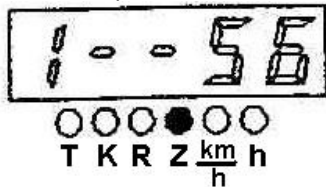

Table 6

Number of teeth (Z1)	Tractor make
69	Belarus 590; 80.1; 890; 900; 922; 950

rear wheel rolling radius (parameter "R") from Table 7:

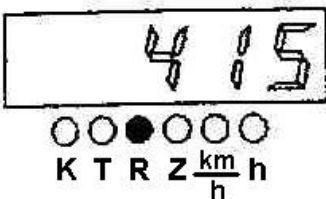

Table 7

Tyre mark	16,9R30	18,4L30	15,5R38	9,5-42	18,4R34 (Φ-11)	16,9R38	18,4R38
Rk, m	0.698	0.720	0.755	0.730	0.770	0.800	0.830
Number coded	700	720	755	730	770	800	830

2. To display correctly the engine rotational speed, it is necessary to program the gear ratio of the alternator drive (parameter "K2") from Table 8 in the specified order:

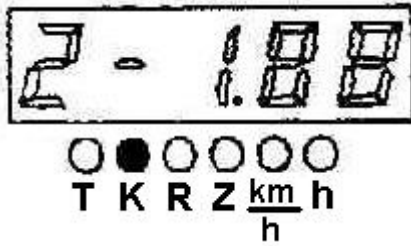

Table 8

Gear ratio of the alternator drive (K2)	Engine mark			
	2.36	Д-242	Д-243	Д-245

3. To display correctly the PTO's rotational speed (540 and 1000), it is necessary to program the gear ratios of the PTO 540 "K3" and PTO 1000 "K4" from Table 9 and the number of teeth of the pinion at the place of installation of the PTO sensor "Z2" in the specified order:

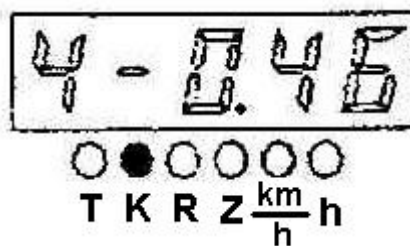
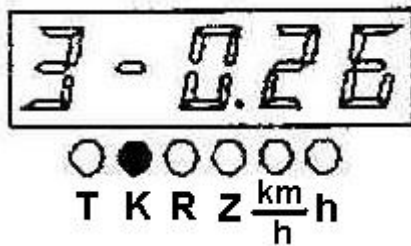
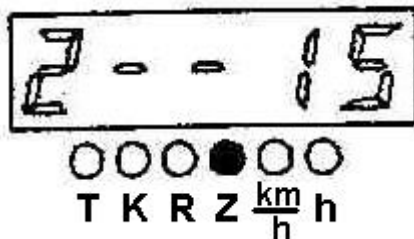

Table 9

The gear ratio of the PTO drive	Engine mark			
		Д-242	Д-243	Д-245
540 (K3)	0.33	0.26	0.26	0.33
1000 (K4)	0.60	0.46	0.46	0.60



- in case of absence of the PTO rotational speed sensor (from the phase winding of the alternator serves as that for indication of the PTO rotational speed), the entered value of the parameter "Z2" shall be equal to 0.

1.8. Indicator Diagnostics and Troubleshooting

1. The diagnostics of the faults according to items 1-3 and 5 is similar to that of the tachospeedometer;

2. Over- or understated readings of the engine rotational speed and PTO's rotational speed (with the normal movement of the pointer):

Check the correctness of programming the instrument according to the gear ratio of the alternator drive (parameter "K2"): (see item 1.7);

3. Over- or understated readings of the tractor speed:

1. Check the correctness of programming the instrument according to the rolling radius of the rear wheels (R) (see item 1.7);

2. Check the correctness of programming according to the number of teeth of the half-axle pinion (Z1) (see item 1.7);

3. Check the correctness of programming of the gear rate of the wheel reduction gear (K1) (see item 1.7).

4. No readings of the tractor motion speed:

Check the presence of the signals from the both speed sensors (BV1, BV2).

5. Signalling of operation of the speed sensor in case of absence of a signal from one of them:

a) in case of absence of the signal from the right wheel speed sensor (BV1), the symbol "□" is displayed on the right of the digital indicator within 12 s after starting the motion; check the connection and serviceability of the right wheel speed sensor;

b) in case of absence of the signal from the left wheel speed sensor (BV2), the symbol "□" is displayed on the left of the digital indicator within 12 s after starting the motion; check the connection and serviceability of the left wheel speed sensor.

1.9. Combined indicator AP80.3813 and combined indicating unit КД8105 (mounted on the tractors with the instrument dashboard 826-3805010)

The combined indicator (hereinafter referred to as the CI) and the control board (hereinafter referred to as the CB) monitor the operational parameters of the systems and units of the Belarus tractors and provide the operator with the information on malfunction or failure of a particular system.

The CI includes the indicators and alarm lamps monitoring the following parameters:

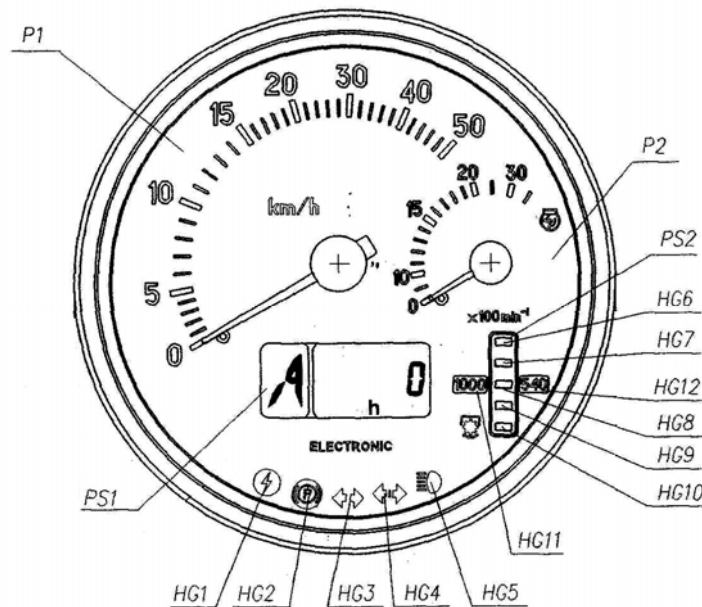

P1 – speed indicator (pointer-type);

P2 – engine rotational speed indicator (pointer-type);

PS1 – LCD, multifunction indicator (for the description and principle of operation of the PS1 in more detail, see below)

PS2 – PTO rotational speed indicator (light indicator);

HG1 – pilot lamp-alarm of the overvoltage in the on-board power supply system (red);

HG2 – pilot lamp-alarm of the parking brake application (red);

HG3 – pilot lamp-indicator of switching on the turn indicators of the tractor (green);

HG4 – pilot lamp-indicator of switching on the turn indicators of the trailer (green);

HG5 – pilot lamp-indicator of switching on the upper beam of the headlights (blue);

HG6, HG10 – PTO scale segments (yellow);

HG7... HG9 – PTO scale segments (green);

HG11, HG12 – scale range indicator of the PTO 1000 and 540, respectively (yellow);

Operating principle of the PTO rotational speed indicator:

1. In the absence of the PTO rotational speed sensor, the designations of the “540” and “1000” scales as well as the indicator of the scale ranges HG11, HG12 light up simultaneously on starting the engine (when a signal comes from the phase winding of the alternator).

The indication of the PTO scale segments (with the account of the selected value of the coefficient “KV2”) occurs on reaching the calculated PTO rotational speed equal to 750 (rpm).

For reference: the indication of the PTO scale segments occurs on reaching the engine rotational speed of 1400-1500 (rpm) and more.

Here, depending on the selected PTO speed mode (540 or 1000), the lit PTO scale segments designate the rotational speed values according to Table 10.

Table 10

Values of operation of the “1000” scale segments (rpm)	Segment location on the scale	Values of operation of the “540” scale segments (rpm)
1150	HG6	650
1050		580
950	HG8	500
850		420
750*	HG10	320

2. In the presence of the PTO rotational speed sensor installed over the pinion of the PTO shank, the combined indicator selects automatically the range (320-750 or 750-1250) depending on the rotational speed of the shank that is accompanied visually by switching on the backlight of the digital designation of the scale – “540” (HG11) or «1000» (HG12), here the threshold values of operation of the scale segments change in accordance with the requirements of Table 10.

The five LED 5 scale segments (HG6 ... HG10) of the PTO light up starting from the bottom one including the segment with the current value of the PTO rotational speed included in the range of the lit state of that segment.

Notes:

- (*) is the rotational speed value, at which the “1000” scale designation is switched on;
- the “540” scale designation is only switched on in the presence of the signal from the sensor and switched on switching on the “1000” designation or in case of absence of the signal for more than 3 s.
- the exact value of the PTO rotational speed can be seen on the indicator PS1.

PS1, the LCD multifunction indicator displays simultaneously:



LCD information fields

1. Digital designation of the position of the gearbox control level (digits from 0 to 6) or lettering of the reduction gear switch (letters L, M, H, N);
2. Current numerical value of one of the parameters of the tractor systems.

The combined indicator receives the information on the position of the gearbox control lever from the transmission control unit (if the complex electronic control system (CECS) is available) or

from the control unit of the range reduction gear (if provided). This parameter is displayed on the information field “1”. If the control units are absent or not connected or in case of wire breakage, the letter “A” is displayed in the information field “1”.

The information field “2” displays the following parameters:

1. Total astronomic time of running the engine in hours.

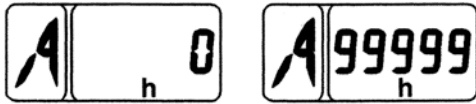

The counter accumulates the information on the total engine running time and saves the same on switching off the power supply.

The reading range is from 0 to 99999 hours of the engine running.

2. PTO rotational speed:

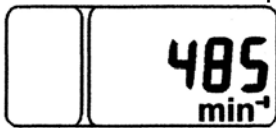

In this mode, the PTO rotational speed is displayed in the digital form depending on the signal from the PTO rotational speed sensor.

The mode is active if the tractor is equipped with the PTO rotational speed sensor.

3. Volume of the fuel remaining (if the frequency fuel volume sensor FFVS is provided):

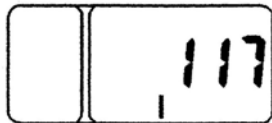

In this mode, the current volume of fuel in the tank (in litres) is displayed.

Attention! This mode is only available on the stopped tractor in the absence of signals from the speed sensors.

NOTE. To switch over between the indication modes “Total astronomic time of running the engine”, “PTO rotational speed”, “Volume of the fuel remaining” and fault messages, press the “Mode” button of the control panel.

Operating principles of the pilot lamps

HG1 is the indicator of the overvoltage in the on-board power supply system:

It lights up when the voltage of the on-board power supply system of the tractor exceeds 19 V and goes out when the power supply voltage level drops down to 17 V;

In this case the CI is fully de-energized and restores its serviceability when the voltage drops down to the rated value.

HG2 is the indicator of the parking brake application:

The “Parking brake” (Стояночный тормоз) indicator starts blinking on operation of the parking brake switch;

HG3, HG4 is the indicator of switching on the turn indicators of the tractor and trailer:

It blinks when the right or the left turn indicator is switched on by the steering-wheel-mounted multifunction switch.

HG5 is the indicator of switching on the upper beam of the road headlights; it lights up when the upper beam of the road headlights is ON.

Note! The indicators light up and go out synchronously with the changes in the states of the system sensors.

Indicator control board

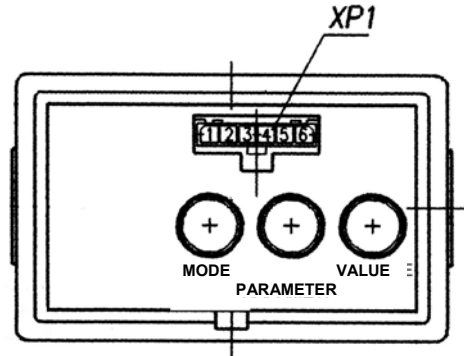

The programming board makes it possible to perform the manual programming of the combined indicator by means of the “Parameter” (Параметр) and “Value” (Значение) buttons and to modify the mode of display of the parameters to be shown on the LCD.

The diagnostic connector **XP1** located on the front panel of the control board makes it possible to perform the automatic programming (reprogramming) of the CI by means of a special instrument (if provided). Should such an instrument be unavailable, the programming shall be performed by means of the above buttons.

1.10. CI programming procedure

1. On selecting the fixed value of the programming parameter:
 - 1.1. On pressing the “Parameter” (Параметр) button for the first time, the LCD is switched to the mode of viewing the parameter to be programmed and its numerical value. On pressing this button repeatedly, the parameters are switched over cyclically.
 - 1.2. On pressing successively the “Parameter” (Параметр) button, the numerical value of the set parameter to be programmed changes.
 - 1.3. The mode is exited automatically if neither “Parameter” (Параметр) nor “Value” (Значение) button has been pressed within 7.0 sec.

On exiting the mode, the last values of the parameters selected by the “Value” (Значение) button are saved.

2. When entering the unfixed value of the programming parameter:
 - 2.1. Select the parameter, the values of which shall be set, by means of the “Parameter” (Параметр) button;
 - 2.2. Press twice the “Mode” (Режим) button; the least digit of the numerical value starts blinking;
 - 2.3. To change the value of the blinking digit of the parameter, use the “Value” (Значение) button;
 - 2.4. To go to the more significant digit, press the “Parameter” (Параметр) button;
 - 2.5. To exit the mode of programming an unfixed value of any parameter, press twice the “Mode” (Режим) button;
 - 2.6. On exiting the above mode, the digits of the entered value of the parameter become lit steadily;
 - 2.7. The newly entered value is set the last in the list of the parameter values allowed to be programmed;

Entering the parameters to be programmed:

1. To display correctly the tractor motion speed, it is necessary to program in the specified order the following parameters:

Parameter “Z” is the number of teeth of the pinions of the final shafts of the driving wheels (right and left), over which the (rotational) speed sensors are installed;

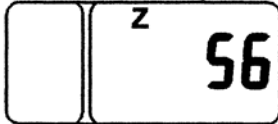

Select from the Table:

Number of teeth (Z)	Tractor make
69	Belarus 590; 80.1; 890; 900; 922; 950

Parameter “I” is the multiplying factor of the gear rate of the wheel reduction gear;

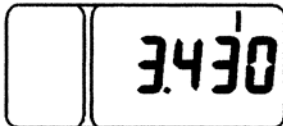

Select from the Table

Gear ratio of the wheel reduction gear (I)	Tractor make
1.000	Belarus 590; 80.1; 890; 900; 922; 950

Parameter “R”

R is the rear wheel rolling radius (mm);

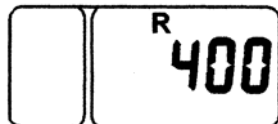

Select from the Table

Tyre mark	16,9R30	18,4L30	15,5R38	9,5-42	18,4R34 (Φ-11)	16,9R38	18,4R38
Rk, m	0.698	0.720	0.755	0.730	0.770	0.800	0.830
Number coded	700	720	755	730	770	800	830

2. To display correctly the engine rotational speed, it is necessary to program in the specified order the gear ratio of the alternator drive (parameter “K”) from Table 8-6:

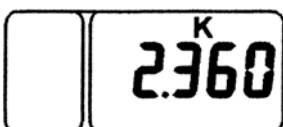

Select from the Table

Gear ratio of the alternator drive (K2)	Engine mark			
	2.36	Д-242	Д-243	Д-245
2.41	D-260			

3. To display correctly the PTO's rotational speeds (540 and 1000), it is necessary to program the gear ratio PTO "KV2" and the number of teeth of the pinion at the place of installation of the PTO sensor "ZV" in the specified order:



Select from the Table

Gear ratio of the PTO drive	Engine mark			
	(KV2)	Д-242	Д-243	Д-245
	0.60	0.46	0.46	0.60

- in the absence of the PTO rotational speed sensor (the signal from the phase winding of the alternator serves as a signal for indication of the PTO rotational speed) the value of the parameter "ZV" to be entered shall be equal to 0.

- in the absence of the PTO rotational speed sensor (the signal from the phase winding of the alternator serves as a signal for indication of the PTO rotational speed) the value of the parameter "KV2" to be entered shall be equal to 0.

4. To display correctly the residue of fuel in the tank (if the FFRS sensor is installed), it is necessary to program the fuel tank volume "V" in the specified order:



For tractors with plastic fuel tank, set the value of 140 litres.

Also, when pressing the "Parameter" (Параметр) button in the programming mode, the list of programmable parameters displays the independent parameter of the adjusted content of the counter of the astronomic time of running the engine. This parameter is unavailable for measurement; it presents the precise (to 1/10 hours) value of the number of hours of the engine running.

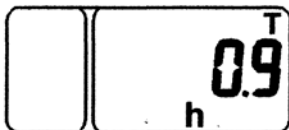

On switching on the backlight of the instrument scales (the main light switch (MLS) is set to the positions II "The backlight of the instrument dash and clearance lights are ON" and III "The consumers of the position II and front road headlights and clearance lights are ON"), the brightness of the PTO indicator segments and LCD is automatically reduced.

IMPORTANT! Each time the power supply of the CI is switched ON, the functioning of the pointer indicators and PTO indicator scale elements is tested. Within one second after this, the indicator pointers deviate from the initial marks beyond the following first marks of the scales (beyond “5” for the motion speed and beyond “10” for the rotational speed), and all the segments and designations “540” and “1000” of the PTO scale are switched on.

1.11. Connecting the tachospeedometer

To connect the tachospeedometer to the instrumentation system, a 13-contact block (XP1) and a 9-contact block (XP2) are provided on the rear panel of the instrument (Fig. 5).

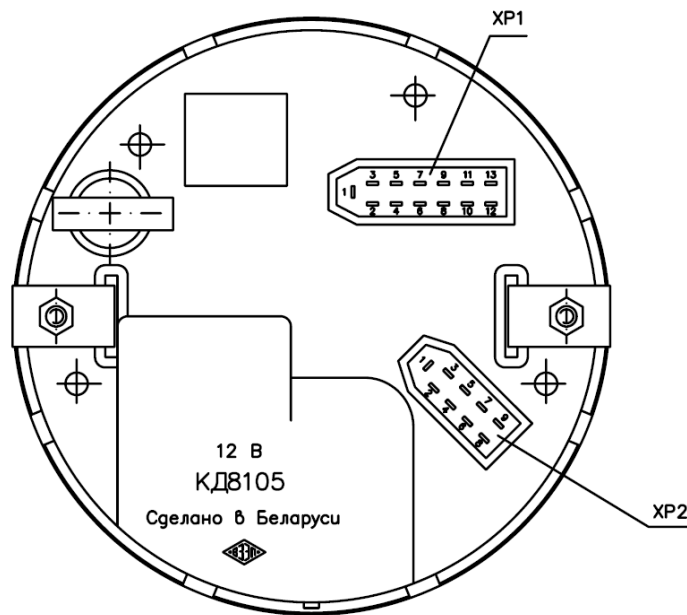

Fig. 5

The identification of the pins of the blocks is given в Tables (11) and (12).

Table 11

Contact	Address of the XP1 connector pin
1	To the terminal “-“ (common)
2	To the power supply unit “+12 V”
3	To the rotational speed sensor “PTO”
4	To the rotational speed sensor “Left wheel”
5	
6	To the rotational speed sensor “Right wheel”
7	
8	To the phase winding of the alternator
9	To the switch of the backlight
10	To the switch of the headlight upper beam
11	To the switch of the trailer turn indicators
12	To the switch of the parking brake
13	To the switch of the tractor turn indicators

Table 12

Contact	Address of the XP2 connector pin
1	To the terminal “-“ (common)
2	To the control board contact “Indication Mode”
3	To the control board contact “Parameter Selection”
4	To the control board contact “Parameter Value”
5	
6	
7	To the fuel volume sensor
8	To the control board contact “M”
9	To the control board contact “+UBZ”

1.12. Indicator Diagnostics and Troubleshooting

1. No instrument backlight:

Check the power supply voltage at the pin “9” of the 13-contact of the contact block (XP1) of the instrument (Fig. 5);

2. Jerking and jumps of the pointer of the engine rotational speed indicator over the dial: poor contact on the alternator terminal and, therefore, poor signal from the phase winding of the alternator. Repair.

3. Jerking of the pointer and understating the reading of the engine rotational speed:

- Check and adjust the tension of the alternator driving belt.

4. Over- or understated readings of the engine and PTO’s rotational speeds (with the normal movement of the pointer):

- Check the correctness of programming the instrument according to the gear ratio of the alternator drive (parameter “K”): (see item 1.10);

5. The counter of astronomical hours of the engine running fails to accumulate the operating time:

- Check the connection of the wire to the contact «8» of the instrument block (XP1) and the presence of the frequency signal from the phase winding of the alternator.

6. Over- or understated readings of the tractor speed:

1. Check the correctness of the instrument programming according to the rolling radius of the rear wheels (R) (see item 1.10);

2. Check the correctness of the programming according to the number of teeth of the half-axle pinion (Z) (see item 1.10).

3. Check the correctness of programming the multiplying factor of the gear rate of the wheel reduction gear (I) (see item 1.10).

7. The “FUEL” reading appears on the indicator display



Check the connection and serviceability of the frequency fuel volume sensor (FFVS) to the contact “7” of the block (XP2).

8. No readings of the tractor motion speed:

- Check the presence of the signals from the both speed sensors (BV1, BV2).

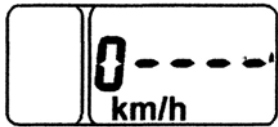
9. The “0km/h----” or “----0km/h” readings appear on the indicator display within 10-12 s after starting the motion of the tractor:

- no signal from the left speed sensor (BV2) check the serviceability of the sensor.

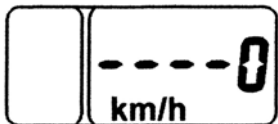

- no signal from the right speed sensor (BV1) check the serviceability of the sensor.

ATTENTION! The speed readings are affected considerably by the speed sensor setting and adjustment performed when replacing or repairing the speed sensor. The gap “S” between the end face of the sensor (2), Fig. ..., and projection of the tooth of the final pinion (6) of the rear axle shall be as specified in Table ... below

A brief message about faults (**Example:** 0----, FUEL) is shown according to the priority on the LCD regardless the information displayed. On pressing successively the “Mode” (Режим) button, the messages shall be paged. When viewing the last message and pressing repeatedly the “Mode” button, the LED is switched to the mode of displaying over the cycle of the operating parameters specified below. The faults are displayed on the LCD each time the instrument is switched on until the fault is eliminated.

Note:

- On switching on the power supply of the CI, the LED shows the information in the indication mode selected until the power supply of the CI is switched off in case of absence of the messages about faults.

1.13. Setting and Adjustment of the speed sensors (BV1, BV2) (Fig. 6)

The speed sensors (2) are fastened by means of the bolts (3) to the cover of the rear axle housing (1) in the zone of the left and right final pinions (6) of the final drives.

The gap "S" between the end face of the sensor and projection of the tooth of the final pinion shall be adjusted by means of the spacers (5) as follows:

1. Measure the dimension "H" from the surface of the cover (1) to the tooth projection;
2. Select and place the necessary number of spacers for setting the gap "S" corresponding to the measured value "H" (see Table 13);

Install the ground wire (4) and tighten the bolts (3).

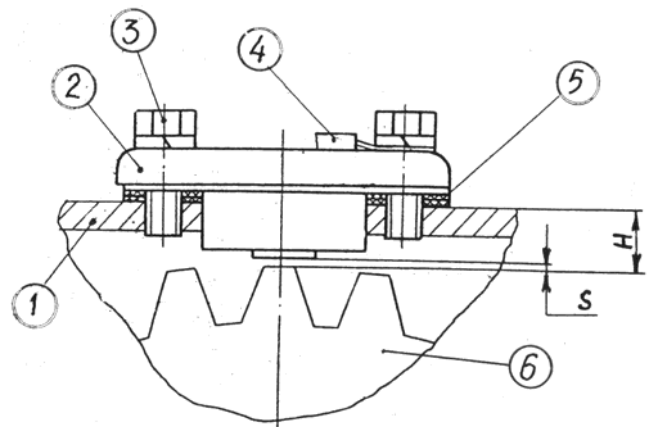

Fig. 6. Setting the speed sensors:

- 1 – cover of the rear axle cover;
- 2 – speed sensor (BV1, BV2);
- 3 – bolt;
- 4 – ground wire;
- 5 – adjusting spacers;
- 6 – final pinion.

Table 13

H, mm	Number of spacers (Pos. 5)	S, mm	Note
11.25-12	4	1.05-1.6	When using the cover (1) with the thickness S=6 mm
12.1-13	3	0.8-1.8	
13.1-13.73	2	0.9-1.53	
13.25-14	2	1.05-1.8	When using the cover (1) with the thickness S=8 mm
14.1-15.73	1	0.9-2.53	

1.14. Combination meter (Fig. 7)

The combination meter includes the five gauges (1, 2, 3, 4, 5) monitoring the various parameters of the tractor. All the gauges are provided with emergency control lamps. The gauges (1, 2, 3, 5) have the red control lamps, and the indicator (4) – the yellow control lamp. To switch on the combination meter, turn the key of the starter and instrumentation switch (SA6) to the "I" position. In this case, the pointer of the oil pressure indicator (2) and temperature indicator (1) shall move to the zero marks of the scale and the pointers of the air pressure indicator (3), fuel level indicator (4) and voltage indicator (5) shall be set to the positions corresponding to the actual positions of the parameter monitored.

The electrical circuit of the instruments is protected by the fuse "2" in the unit (F2).

Engine cooling fluid temperature indicator

(1) with the emergency temperature control lamp (red). It operates with the temperature sensor (BK1). The indicator scale has three zones:

- operating – 80...100°C – green;
- non-operating – 40...80°C – yellow;
- 100...120°C – red.

Engine oil pressure indicator (2)

with emergency pressure drop control lamp (red). It operates with the pressure sensor (BP1).

The indicator scale has three zones:

- operating – 100...500 kPa – green;
- non-operating – 0...100 kPa and 500...600 kPa – red.

When starting the cold engine, the pressure of up to 600 kPa is possible.

Indicator of the air pressure in the pneumatic system (3) with the red emergency pressure control lamp. It operates with the air pressure sensor (BP2).

The indicator scale has three zones:
 - operating – 500...800 kPa – green;
 - non-operating – 0...500 kPa and 800...1000 kPa – red.

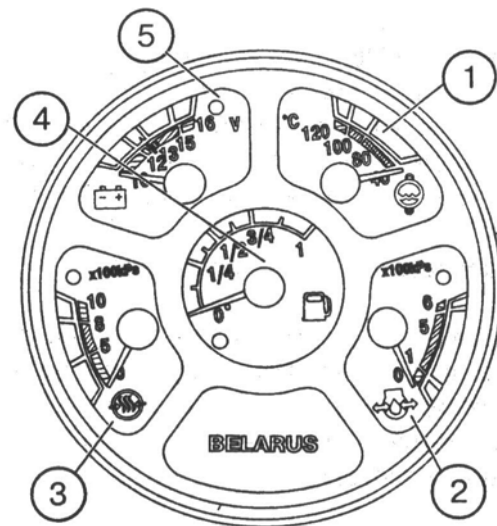





Fig. 7. Combination meter:

- 1 – engine cooling fluid temperature indicator;
- 2 – indicator of the engine oil pressure;
- 3 – indicator of the air pressure in the pneumatic system;
- 4 – indicator of the fuel level in the tank;
- 5 – indicator of voltage of the storage battery or alternator.

Scale zones marked by hatching:

-  – red
-  – yellow
-  – green
-  – orange

Indicator of the fuel level in the tank (4) with orange control lamp of reserve level. It operates with the fuel level sensor (BN1). The instrument has the points: 0-1/4-1/2-3/4-1.

Do not allow consuming the fuel to empty tank (instrument pointer is at orange zone).

Voltage indicator (5) with the red control lamp red of additional SB charging.

It displays the SB voltage, when the engine is running and the starter switch key is in the "I" position. When the engine is running, it indicates the voltage at the generator terminals.

The reading values are given in Table 14 below.

Table 14

Scale zone, colour	Power supply system state	
	when the engine is running	when the engine is not running
13.0 – 15.0 V green	Normal charging mode	
10.0 – 12.0 V red	Generator is not working	SB is run down
12.0 – 13.0 V yellow	No charging of SB (low charging voltage)	SB has normal charging
15.0 – 16.0 V red	SB overcharging	SB has normal charging
White hairline in yellow zone		The rated emf of the SB is 12.7 V

1.15. Connection the combination meter

To integrate the combination meter to the instrumentation system, the rear panel is provided with two blocks X1 and X2 (Fig. 8).

The purpose of the contacts of the blocks of the combination meter is shown in Tables 15, 16.

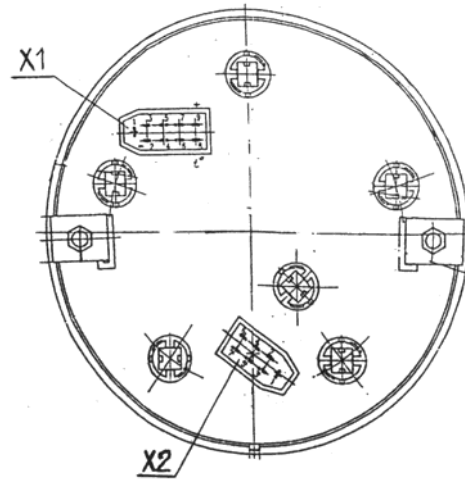

Fig. 8. Blocks for connecting the combination meter (rear view):

X1 – 9-contact block;
X2 – 7-contact block.

Block X1

Table 15

Contact	Address
1	To the instrument backlight switch
2	To the “-” terminal of the battery
3	Monitoring the storage battery charging
4	Buzzer
5	To the sensor of the oil pressure in the engine (BP1)
6	To the sensor of the emergency temperature of the engine cooling fluid (SK1)
7	To the sensor of the emergency oil pressure in the engine (SP2)
8	To the sensor of the cooling fluid temperature (BK1)
9	To the “+” SB terminal (12 V)

Block X2

Table 16

Contact	Address
1	Reserved
2	Reserved
3	To the fuel level sensor (BN1)
4	To the gearbox oil pressure sensor (not used)
5	To the sensor of emergency drop of the air pressure (SP4)
6	To the sensor of the reserve fuel level (BN1)
7	To the sensor of the air pressure (BP2)

1.16. Combination Meter Diagnostics and Troubleshooting

1. No backlight of the instrument scales on setting the SA10 central light switch:

1. Check the presence of the power supply voltage at the terminal "1" of the block "X1" (to the instrument backlight switch) and at the terminal "9" (to the power supply unit "+ 12 V").

In case of absence of the voltage, eliminate the open circuit. If the voltage is present:

2. Check the intactness of the backlight lamps and replace them, if necessary.

2. The temperature indicator (1), Fig. 9, operated jointly with the thermistor-type temperature sensor BK1 (ДУТЖ-02М, resistance range: 243...22.5 Ω).

2.1. The temperature indicator pointer goes off-scale:

1. Breakage of the wire to the terminal "9" of the block "X1" ("+" 12 V of the SB);

2. Breakage of the wire to the terminal "2" of the block "X1" ("-" of the power supply);

3. If there is no breakage, the temperature indicator is faulty.

2.2. The pointer of the temperature indicator is set before the initial point of the scale:

1. Breakage of the wire to the terminal "9" of the block "X1" ("+" 12 V of the SB);

2. Breakage of the wire to the terminal "8" of the block "X1" (to the temperature indicator BK1);

3. Fault of the temperature sensor;

4. Fault of the temperature indicator.

3. Indicators of the oil pressure in the engine (2) and air pressure in the pneumatic system (3). They operate from the following sensors:

Rheostat-type oil pressure (BP1) (ДД-6М; 10...184 Ω) and rheostat-type oil pressure (BP2) (ДД-10-01М).

3.1. The indicator pointer is set before the initial point of the scale:

1. Breakage of the wire to the terminal "2" of the block "X1" ("-" of the power supply);

2. Breakage of the wire to the terminal "9" of the block "X1" ("+" of the power supply);

3. If there is no breakage, the pressure indicator is faulty.

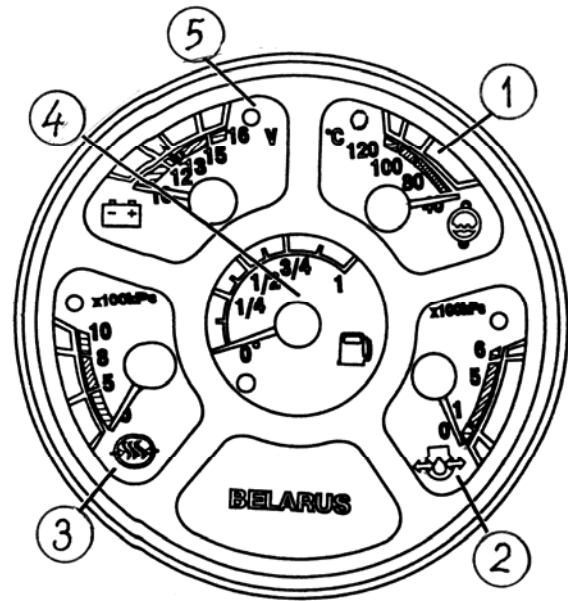

Fig. 9.

IMPORTANT! To avoid errors in the temperature indication, use the ДУТЖ – 02М temperature sensors mentioned above.

3.2. The indicator pointer goes off-scale:

1. Breakage of the wires to the terminals "4", "5", "7" of the block «X1» or short circuit inside the indicator;

2. The pressure indicator is faulty.

4. Fuel level indicator (4).

It operates with the float-type rheostat sensor (BN1) installed in the fuel tank (ДУМП-21М (320...0 Ω)).

NOTE! Should there be no fuel in the tank when switching on the indicator; the indicator pointer shall be at the initial point of the scale. If the indicator is switched off or there is a wire breakage, the indicator pointer shall go off-scale.

4.1. The indicator pointer is before the initial point of the scale:

1. Breakage of the wire to the terminal "9" of the block "X1" (to the terminal "+12V");

2. Breakage of the wire to the terminal "3" of the block "X2" (to the fuel level sensor);

3. The fuel level sensor is faulty; if there is no breakage and the sensor is in good repair, replace the combination meter

or repair the fuel level indicator.

4.2. The indicator pointer goes off-scale:

1. Breakage of the wire to the terminal «2» of the block “X1” (output “-“ of the power supply);
2. If there is no breakage, the fuel level indicator is faulty. Repair the indicator or replace the combination meter.

Front windscreen washer switch (1)

Pressing the button (1) switches the windscreen washer on.

Three-position light switch (2)

The button (2) has three positions:

- “OFF”;
- “Dashboard lighting, clearance lights and number plate light ON”;
- “All control lamps units including the front headlights ON”.

Fault signalling switch (3)

Pressing the button (3) switches the fault signalling on. There is a control lamp inside the button, which blinks simultaneously with the flashing light signalling.

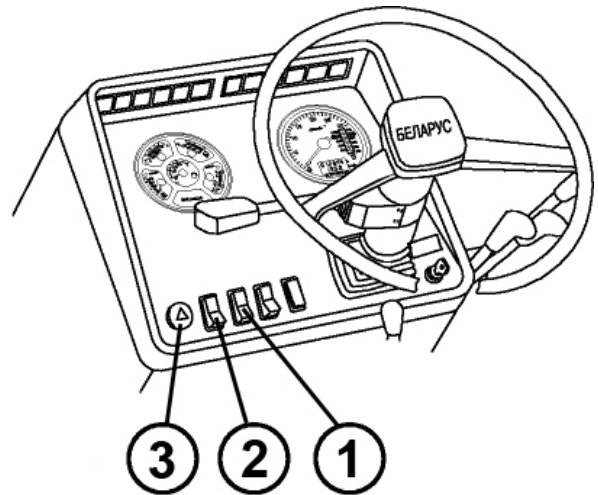

Steering-Wheel-Mounted (Multifunction) switch (1)

It ensures the switching-on of the turn indicators, toggling the beam of the road headlights (lower/upper beam), warning by upper beam warning and horn beep.

Turn indicator

Turning the arm (1) up or down switches on the right or left turning indicator, respectively.

NOTE: After completing the turn of the tractor, the arm (1) is returned automatically to the neutral position.

Upper/lower beam

When the road headlights are switched on by the switch (2), pushing the arm (1) switches the “upper beam” on and pulling the same switches the “lower beam” on. Pulling the arm (1) further from the “lower beam” position towards the operator up to the stop switches on shortly the upper beam (non-fixed position).

Horn beep

Pressing the arm (1) in axial direction switches the beep on.

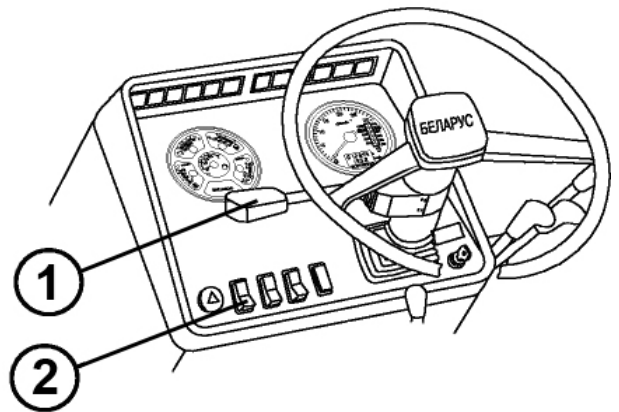

Front windscreen wiper switch (1)

Pressing the button (1) switches front windscreen wiper on.

The switch has three positions:

- OFF;
- Low speed ON;
- High speed ON.

NOTE: In the “OFF” position windscreen wiper automatically returns to initial position

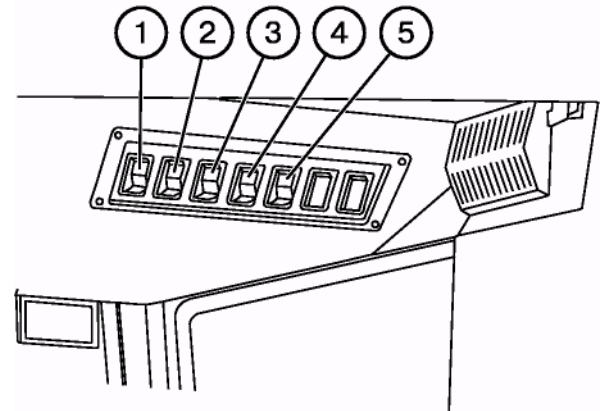

Cab heater and fan switch (2)

Pressing the button (2) switches the cab air ventilation on.

The switch has 3 positions:

- “OFF”;
- “Low air supply mode ON”;
- “High air supply mode ON”.

Rear working lights switch (3)

Pressing the button (3) switches the rear working lights on or off. The lights being on, the button (3) is illuminated with a built-in backlight lamp.

Front working lights switch (4)

Pressing the button (4) switches the front working lights on or off. The lights being on, the button (4) is illuminated with a built-in backlight lamp.

Road-train sign lighting switch (5)

On pressing the button (5), the three orange lights on the roof forepart are switched on and the button is backlit.

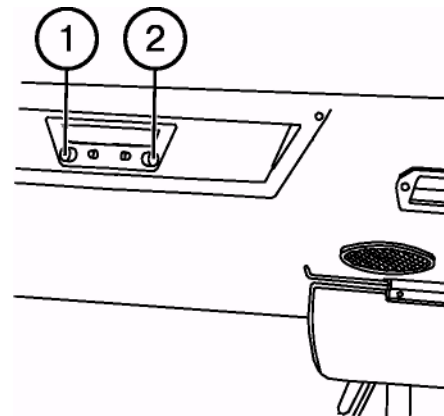

Radio receiver switch

(if installed)

- 1 – On (Off) and volume control;
- 2 – Tuning.

NOTE: The radio receiver operates only in starter key positions I or III only.

Control lamps of the dashboard (dashboard 80-3805010-Д1)

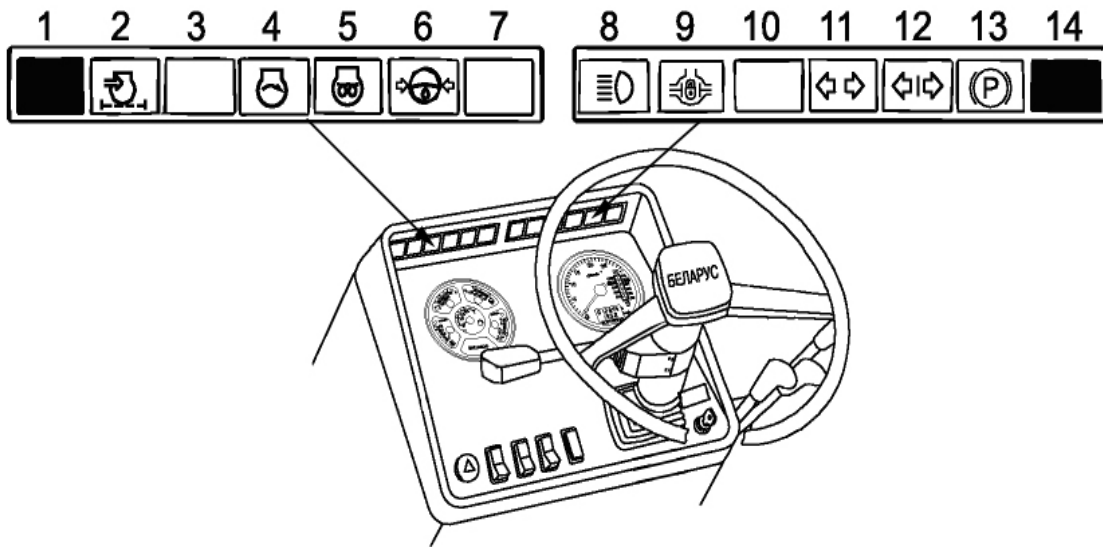

1 and 14 – Buttons for testing the serviceability of the control lamps unit. On pressing the button, all the lamps shall be lit.

2 – Air filter blocking. The control lamp (orange) lights up when the maximum allowed level of filter blocking is exceeded and it needs cleaning.

3 – Reserved.

4 – Engine start lamp: This orange control lamp lights up on turning the starter switch key to position II to indicate that the starting system functions properly. If the lamp blinks at the frequency of 1.5 Hz, the gearbox control lever is not in neutral position or the engine starting locking switch circuit is out of order. If the lamp blinks at the frequency of 3.0 Hz, there is a failure in the alternator phase winding circuit. Eliminate the fault and restart.

5 – Starting aid lamp: This orange control lamp is on when pressing the button of electric torch pre-heater (ETP). After 30 s the lamp will start blinking, indicating that diesel engine starting system under cold conditions is ready for operation.

6 – HPS emergency oil pressure. The lamp (red) lights up when oil pressure in HPS feeding system is below the allowable level.

7 – Reserved.

8 – Upper beam indicator: Blue control lamp lights up when switching on the upper beam of the front headlights.

9 – Rear axle differential locking control lamp. The lamp (green) is on when switching automatic differential locking (ADL).

10 – Reserved.

11 – Tractor turn indicator (green).

12 – Trailer turn indicator (green).

13 – Parking brake indicator (red).

Control lamps of the dashboard (dashboard 826-3805010)

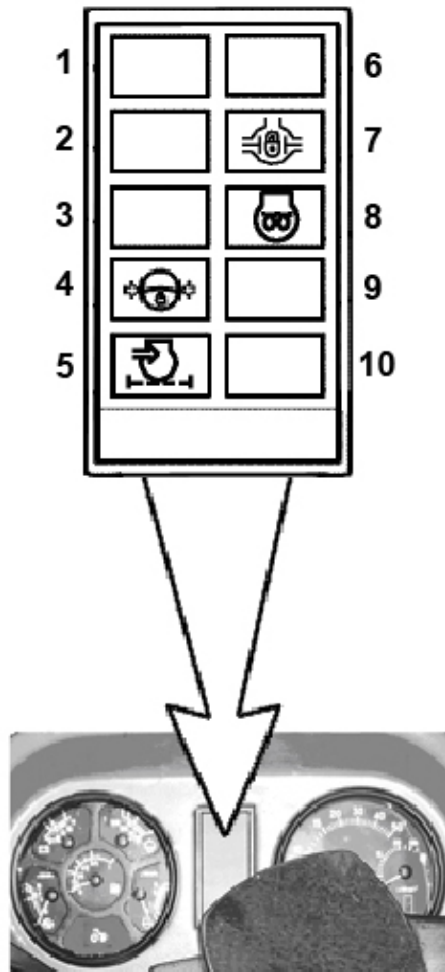

- 1 – Reserved indicator (green)
- 2 – Reserved indicator (green)
- 3 – Reserved indicator (red)
- 4 – HPS emergency oil pressure. The lamp (red) lights up when oil pressure in HPS feeding system is below the allowable level.
- 5 – Air filter blocking. The control lamp (orange) lights up when the maximum allowed level of filter blocking is exceeded and it needs cleaning.
- 6 – Reserved indicator (blue).
- 7 – Rear axle differential locking control

lamp. The lamp (green) is on when switching automatic differential locking (ADL).

8 – Starting aid lamp: This orange control lamp is on when pressing the button of electric torch pre-heater (ETP). After 30 s the lamp will start blinking, indicating that diesel engine starting system under cold conditions is ready for operation.

9 – Reserved indicator (red).

10 – Reserved indicator (red).

Fuses

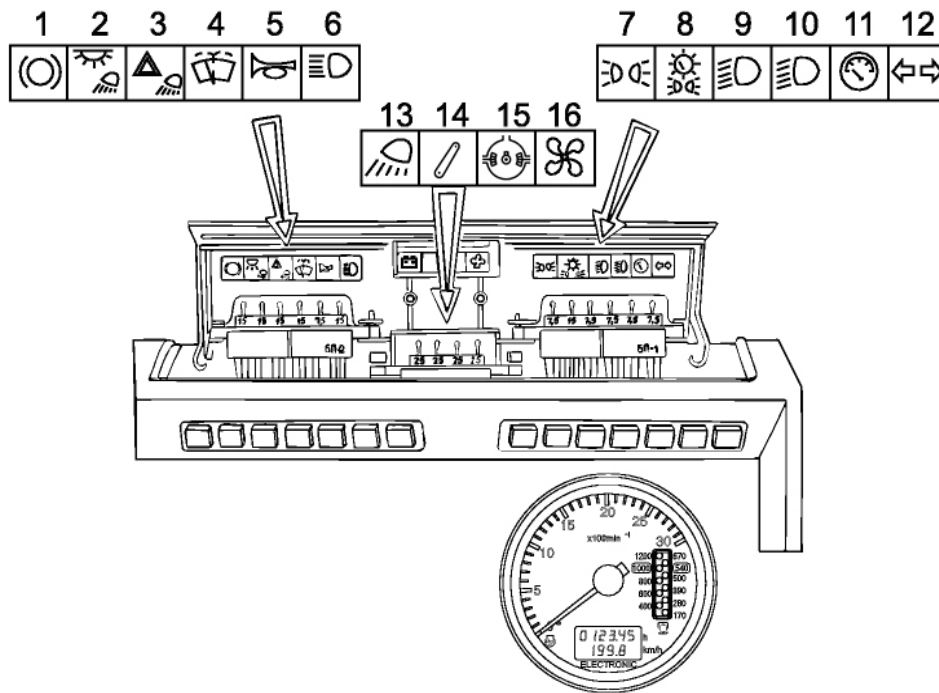

Three electric circuit fuse boxes are installed in the dashboard. To get access to the fuses, remove the screw on the dashboard cover and open it.

The fuses protect the following electric circuits of the tractor against overloads:

- 1 – Braking signal (15 A);
- 2 – Cab light and rear working lights (15 A);
- 3 – Fault signalling (15 A);
- 4 – Windscreen wiper and washer (15 A);
- 5 – Horn (7.5 A);
- 6 – Upper beam of the road headlights (15 A);
- 7 – Left clearance lights (7.5 A);
- 8 – Right clearance lights and backlights of the dashboard and registration plate (15 A);
- 9 – Lower beam of the left road headlight (7.5 A);

- 10 – Lower beam of the right road headlight (7.5 A);
- 11 – Instrumentation, control lamps block, parking brake indicator (7.5 A);
- 12 – Turn indicator relay (7.5 A);
- 13 – Front working lights (25 A);
- 14 – HMS supply (25 A);
- 15 – Side board supply (PTO, DL) (15 A);
- 16 – Heating system fan (25 A).

The storage battery charging circuit is protected with the fuse rated at 60 A.

WARNING! To prevent the electric wiring from burning, never apply fuses of higher current rating than specified above. If the fuse blows often, detect the reason and eliminate it.

In case of blowing of the fuse due to a short circuit, proceed as follows:

1. Connect the wires from the pilot lamp to the terminals of the fuse box at the place of the fuse blown.
 - a) If there is a short circuit, the lamp will be lit with incandescence,
 - b) If the circuit and consumer are intact, the lamp will not be lit or will be lit dimly.
2. Connect the circuit from the fuse to the consumer and ensure that the lamp is not lit or is lit dimly (in the presence of a switched on consumer in the circuit);
3. Fit a new fuse.

During the operation, the contact resistance between the fuse and its holders can increase due to oxidization.

It results in increase of the voltage drop in the circuit and heating causing the circuit failure. The defect is detected by the disturbance of the operation of the consumer (reduction of the power) and heating of the fuse. Eliminate the defect by cleaning the holder and fuse from the oxide film.

Electric equipment connector components

A **standard 8-pin socket** is designed for connecting the current-consuming units of a transport machine or trailed agricultural implement. It is installed on the cab's rear support. A plug of the wire bundle of the hitched machines is connected to the socket.

Socket connection terminal marking:

- 1 – Turn indicator, left;
- 2 – Horn;
- 3 – “Ground”;
- 4 – Turn indicator, right;
- 5 – Right clearance light;
- 6 – Stop light;
- 7 – Left clearance light;
- 8 – Hand lamp connection.

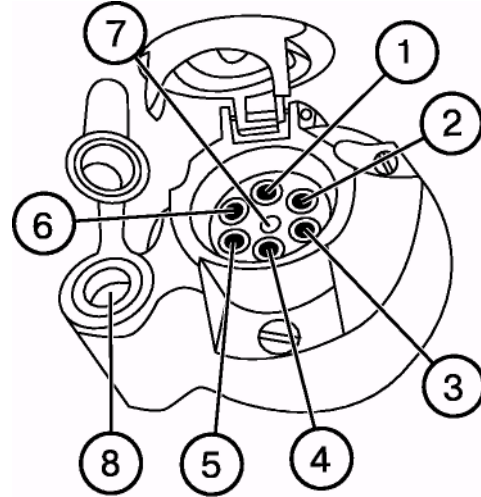

Installing the monitor on the tractor

An electronic monitor can be installed on the cab front wall. There are two openings on the front wall between the front and the lower glasses to the left and right from the dashboard.

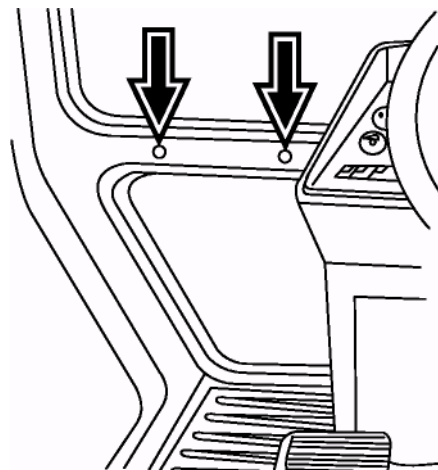

Gearbox single-lever control

The 7F/2R synchronized gearbox combined with synchronized reduction gear allows obtaining 14 forward and 4 reverse gears.

The gears are shifted by means of the lever (1) in accordance with the shifting pattern. Prior to putting in the gear, select the required range (stage).

IMPORTANT! The ranges are selected and the gears are shifted by means of a single lever (1), the range (either I or II) being selected first.

The reduction gear lever (2) shall be always in the engaged: either forward (direct transmission "H") or reverse (retarded transmission "L").

ATTENTION: using the gear "R" in traction mode is not allowed.

NOTE: The lever of the reduction gear or multiplier has no fixed neutral position. The lever is allowed to be set to the neutral position when starting the engine in cold season only.

Multiplier lever (2) has two positions:

- "L" - direct gear (OFF) – foremost position;
- "H" step-up gear (ON).

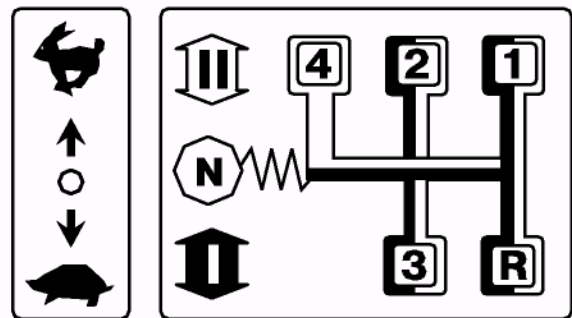
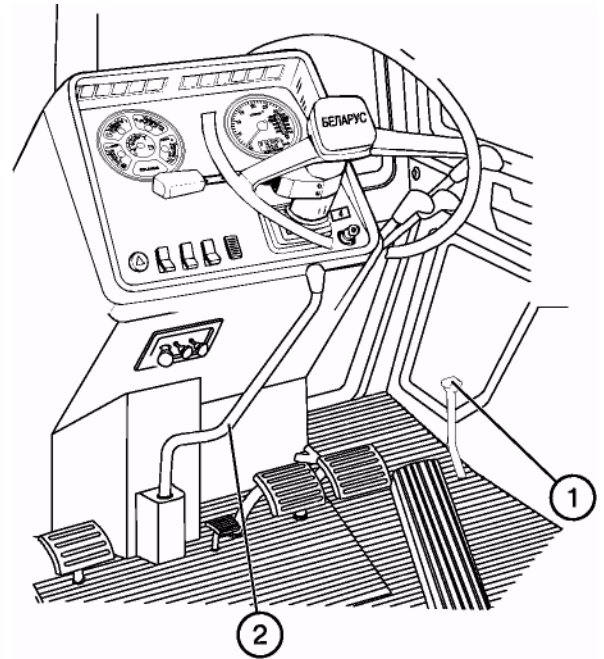

Gearbox two-lever control

The 7F/2R mechanical two-range fixed-ratio transmission gearbox with two-lever control (gears are shifted and the ranges are selected by means of separate levers). Jointly with the synchronized accelerator, the gearbox allows obtaining 14 forward and 4 reverse gears.

Selecting the ranges and shifting the gears

The gears are shifted and the ranges are selected by means of separate levers according to the patterns shown in Fig.

Select the required speed of the tractor motion according to the information plate on the right side glass of the cab.

To put in the gear corresponding to the required speed of the tractor motion, proceed as follows:

1. Step on the clutch pedal and set the required range in the gearbox by moving the range reduction gear lever (2) forward or backward, according to the pattern shown on its handle.

ATTENTION: The stages of the range reduction gear are switched over when the tractor is completely stopped and the clutch pedal is stepped on.

ATTENTION: The gearbox range reduction gear has no neutral position; therefore the 1st or 2nd reduction stage is always engaged in the reduction gear.

2. Step on the clutch pedal and move the change-gear lever (1) to the position of the required gear according to the pattern shown on its handle.

ATTENTION: The first forward gear and the reverse gear are put in after full stop of the tractor with the clutch pedal stepped on.

Putting on the 1st forward gear and reverse gear as well as switching over the stages of the range reduction gear are not synchronized and are performed by movable pinions on the tractor fully stopped. Prior to putting in the said gears or stages

of the range reduction gear release slightly

ATTENTION: To avoid the increased noise in the gearbox, the design of the gearbox control mechanism is provided with an interlock excluding the simultaneous putting-in of the 4th (direct) gear and the 1st stage of the range reduction gear. Therefore, the 4th gear can be put in with the 2nd stage of the range reduction gear only.

and step on fully the clutch pedal again. It will ensure the turning-over of the pinions and light putting-in of the gears or ranges.

3. Start the smooth motion of the tractor in the gear selected by releasing the clutch

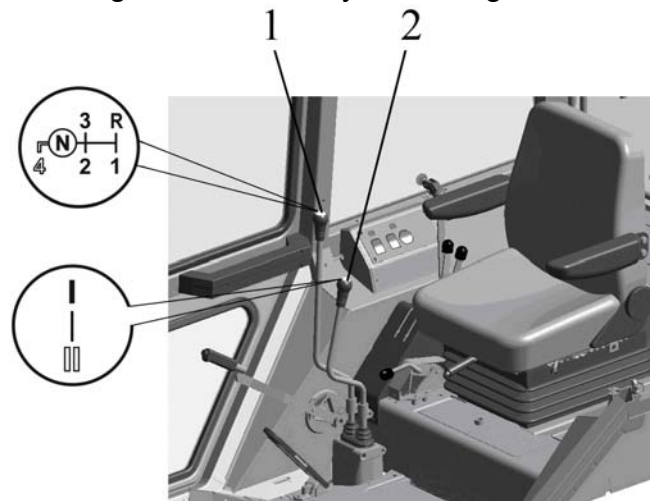

pedal.

ATTENTION: When operating the tractor, do not hold the foot on the clutch pedal. It will prevent the clutch slip, which causes the overheating and premature failure of the clutch.

Shuttle-gear control (if installed)

The shuttle gear is controlled with lever (2) having the following positions:

- ON – rearmost position;
- OFF (forward motion) – foremost position.

ATTENTION! When putting the gearbox lever to position “R” (reverse motion), the lever being in rearmost position, the tractor will move forward.

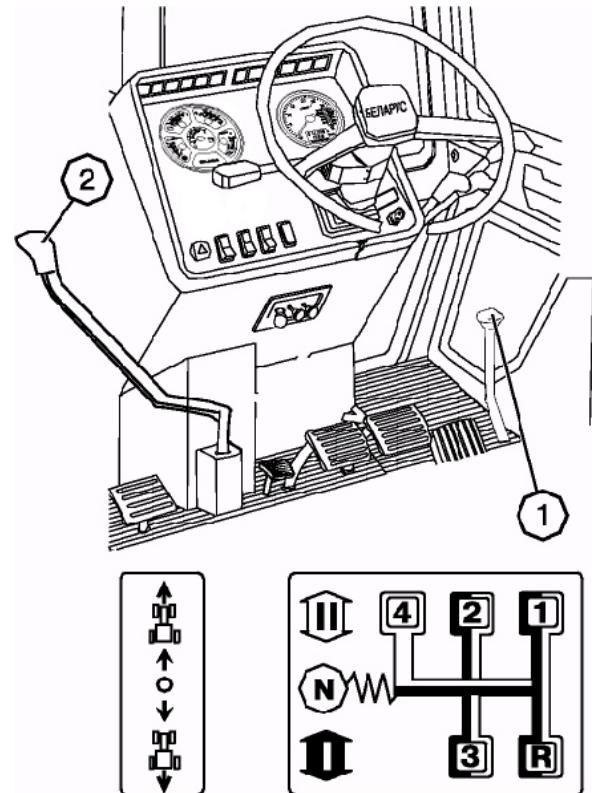

Speed reducer control (if installed)

The change-gear lever of the speed reducer (1) has five positions:

- “OFF”;
- “ON”;
- “N” – neutral;
- “1” – first gear of the speed reducer;
- “2” – second gear of the speed reducer.

The rod for switching over the speed reducer ranges (2) has three positions:

- I – first range corresponding to reduced speeds (lower position);
- II – second range corresponding to increased speeds (upper position);
- N – neutral (mid position).

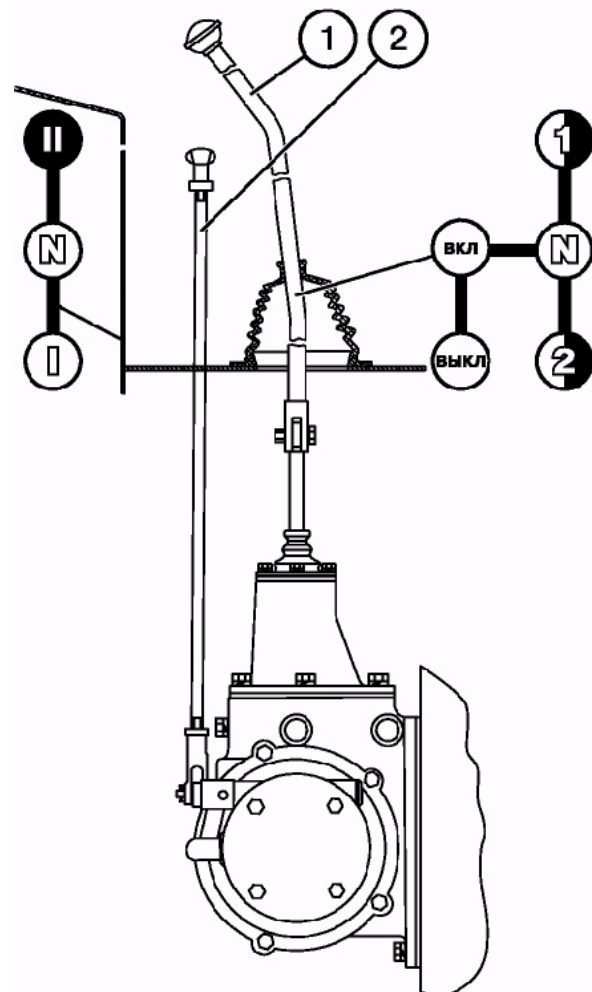

Control of engagement of the front driving axle (Belarus 920/920.2/920.3/952/952.2/952.3)

The control lever (1) has three fixed positions:

- “FDA OFF” – lowermost position. Use it when driving on hard surface roads to prevent the increased wear of the tyres.
- “FDA forcedly ON” – uppermost position. Only use this mode in case of incessant skidding of the rear wheels and when moving backwards, when the engagement of the FDA is required.
- “FDA automatically ON (OFF)” – mid position. In this mode, the FDA is engaged and disengaged automatically by the free running coupling, depending on rear wheel skidding. Use this mode during different field works.

ATTENTION! When using the tractor without cardan shafts, put the control lever (1) to the uppermost position (“FDA forcedly ON”).

Hitch fixation mechanism control (2) (for tractors with power governor)

Lever (2) has two positions:

- “Hitch unlocked” – rightmost position;
- “Hitch locked in upper position” – leftmost. To lock the hitch, lift the implement to uppermost position, having put power governor arm (4) to position «Lifting», and turn handle (2) to the left. Release down arm (4).

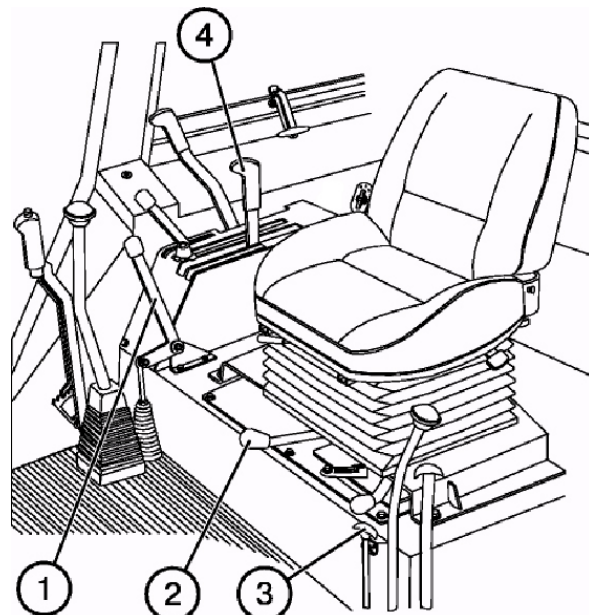

To unlock the hitch, lift the implement and turn lever (2) to the right.

Control of lock of the hydraulic hook (3)

The handle (3) has two positions:

- “Unlocked” – upper position;
- “Locked” – lower position.

To unlock the hydraulic hook, lift it with arm (4) to upper position, pull handle (3) up and fix it. To lock the hook after hitching the trailer to the tractor, lift the hook with arm (4), release handle (3) from fixation and move it to lowermost position.

Rear PTO control

Switch of the independent and synchronized drive of the rear PTO

Lever (1) has three positions:

- “PTO independent drive ON” – right-most position;
- “PTO synchronized drive ON” – left-most;
- “OFF” – mid position.

To engage the synchronized drive, proceed as follows:

- Start the engine;
- Step on the clutch pedal up to the stop and put in the 1st or 2nd gear;
- release slowly the clutch pedal and move simultaneously the lever (1) to the leftmost position.

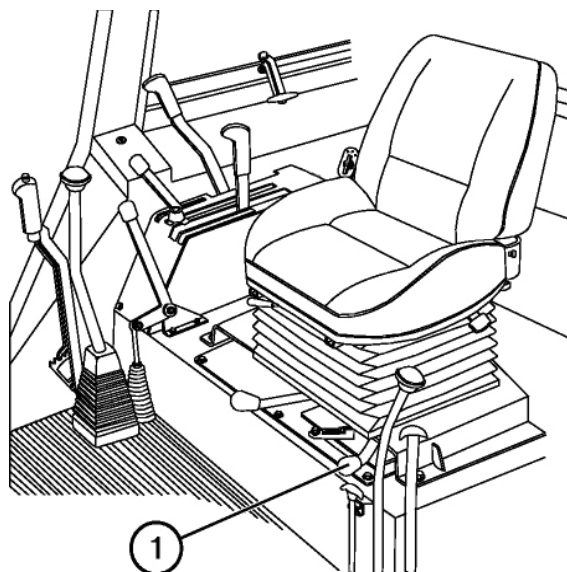

IMPORTANT! Use the synchronous PTO drive in lower gears in the lowest gears of the 1st and 2nd gearbox ranges at the tractor motion speed not more than 8 km/h. Otherwise power transmission can be damaged.

Switch of the 2-speed independent drive of the PTO (2)

The shifter arm (2) of PTO independent drive has two positions:

- I – 540 rpm – extreme, counter-clockwise;
- II – 1000 rpm – extreme, clockwise.

To set the required PTO speed, release bolt (1), rotate the shifter arm (2) to the I or II position and retighten the bolt (1).

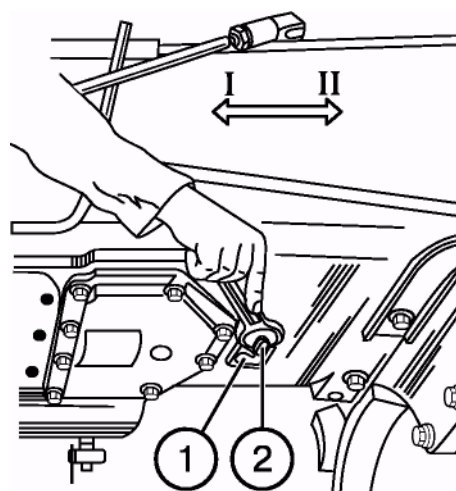

PTO control lever

The PTO control lever (1) has two positions:

- PTO OFF – front position of the lever (1);
- PTO ON – back position of the lever (1).

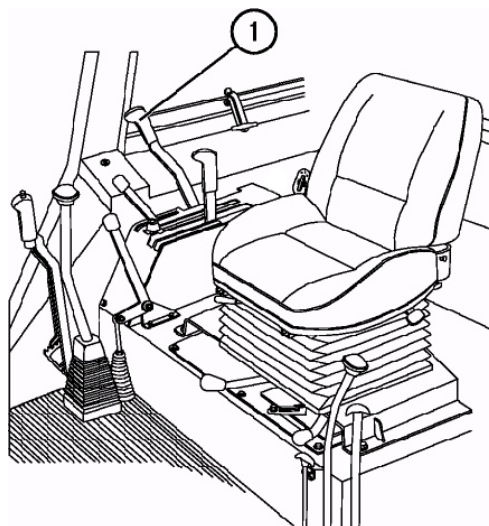

Control of the rear axle differential lock (1)

To engage shortly the lock press pedal (1).

IMPORTANT! Engage the forced differential lock (1) only shortly to overcome road obstacles and carry out the field and transportation works.

WARNING: Do not use the differential lock at the speeds exceeding 10 km/h and when turning the tractor. Otherwise the tractor control becomes difficult and running gear and power transmission are quickly worn out.

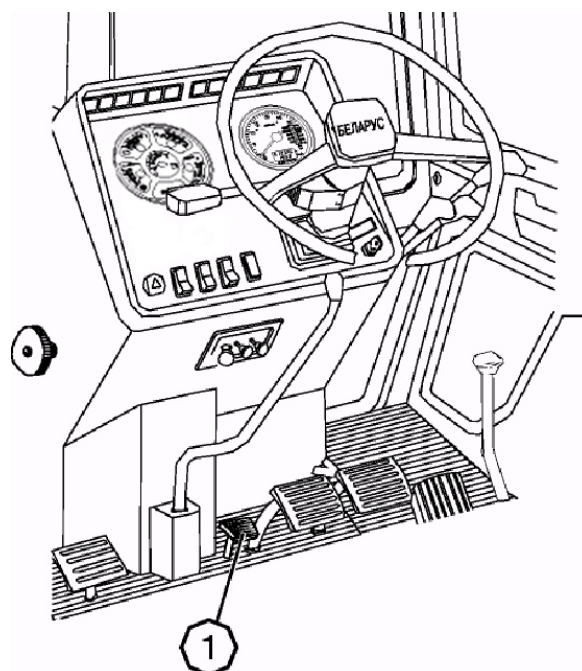

Rear PTO control (for tractors equipped with a hydraulic lift)

To engage the rear PTO, the key switch (4) and push-button switch (5) located on the panel above the right control board are used. The switch (4) has two fixed positions:

- “PTO ON” – when pressing the lower part of the key switch;
- “PTO OFF” – when pressing the upper part of the switch.

To engage the PTO:

- Press the lower part of the key switch;
- Shortly press push-button switch (5). Control lamp (3) will be on and PTO shank will start rotating.

NOTE: On stopping the engine, the PTO is disengaged automatically.

To disengage the PTO, press the upper part of the switch. The pilot lamp will become dim.

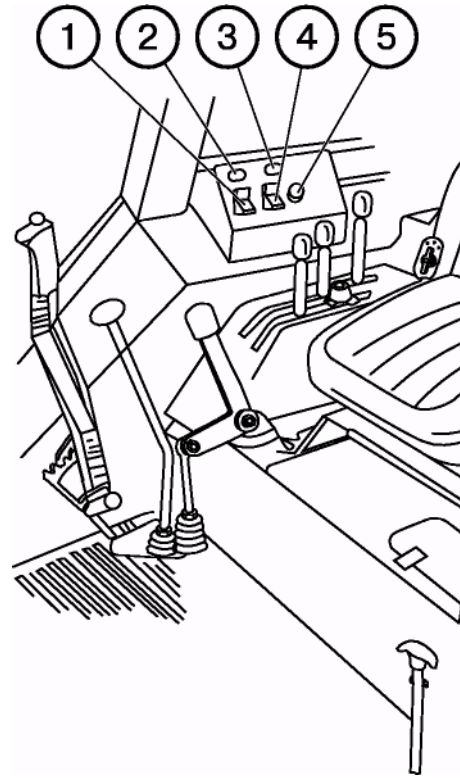

ATTENTION! The PTO engagement operations shall be only performed with the engine running.

Rear axle differential lock control (for tractors equipped with a hydraulic lift)

The differential lock (DL) is controlled with key (1) having three positions:

- “DL OFF” – mid fixed position to be used when performing the transport works on the hard surface roads;
- “DL ON automatically” – by pressing the upper part of the key (1). Fixed position. It is to be used when performing the works with substantial rear wheel skidding.

In the automatic mode, the rear wheels are locked during the straight-line motion and unlocked when turning the guide wheels at the angle exceeding 13° in any direction.

- “DL ON forcedly” – by pressing the lower part of the key (1). Fixed position. It is to be used for locking shortly the rear wheels when overcoming the obstacles. On releasing the lower part of the key, it returns to the mid position. On activating the DL, the pilot lamp (2) lights up, which becomes dim when unlocking the DL in the automatic mode and on setting the key (1) to the mid position.

ATTENTION! Activate the DL under the increased skidding conditions when performing the field and transport works.

IMPORTANT! Disable the DL at the tractor motion speed exceeding 10 km/h. Otherwise, the service life of the power transmission would be shortened and the tractor control would be impeded. The forced locking shall be used shortly only to overcome road obstacles.

Hydraulic system pump control

The control lever has two positions:

- “Pump ON” – upper position;
- “Pump OFF” – lower position.

IMPORTANT! Switch on the pump only at the minimum rotational speed of the engine idling. Disengage the pump when starting the cold engine and maintenance.

Control of the hydraulic system distributor (external cylinder)

Each of three arms controls the external cylinders and has four positions:

- “Neutral” – lower mid position (fixed);
- «Lifting” – lower non-fixed position. When releasing the arm, it returns to “Neutral” (for the distributors P80-3/4-111; PП-70-1221; PП-70-1221C; RS213 Mita; RS213 Belarus). For the distributors P80-3/4-222, this position is fixed. The handles are returned automatically to the “Neutral” position at the pressure of 15.5...20 MPa.
- “Forced lowering” – upper mid non-fixed position between the “Floating” and “Neutral” ones. On releasing the arm, it automatically returns to “Neutral”;
- “Floating” – upper fixed position.

NOTE: If any distributor arm is put into the “Lifting” or “Lowering” position, the operation of the power governor in the automatic control, lifting and lowering modes is interrupted.

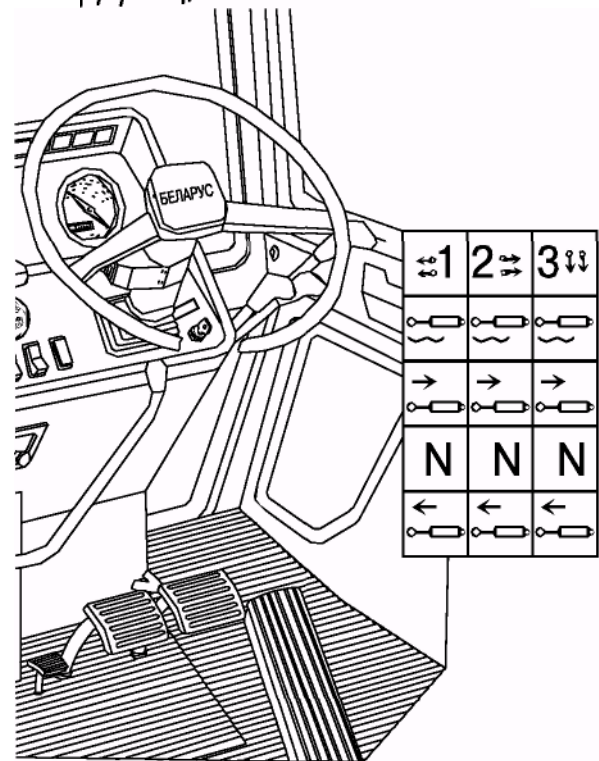
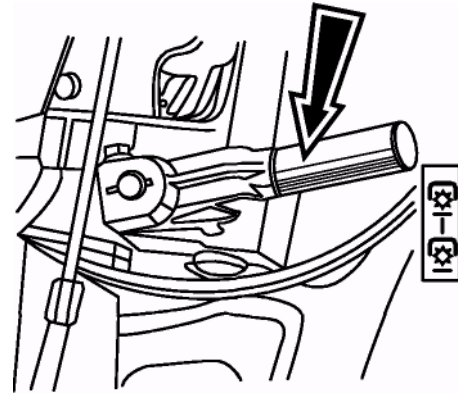

Remote control of the hydraulic system distributor (if installed)

If the tractors are equipped with the RS-213 Belarus hydraulic distributors, the remote control of the distributor spool valves is executed by the manipulator (joystick) (1) and arm (2) with the two-way cords. The manipulator and the arm are mounted on the right control board in the tractor cab.

The manipulator (1) makes it possible to control two distributor spool valves (sections) at the same time:

When shifting the manipulator lever lengthwise, the spool valve connected to the left side outlets of the hydraulic system is controlled.

When shifting the manipulator lever crosswise, the spool valve connected to the right side outlets and rear outlets (optional) is controlled.

The arm (2) can be only shifted lengthwise and controls the central spool valve connected to the rear left outlets of the hydraulic system.

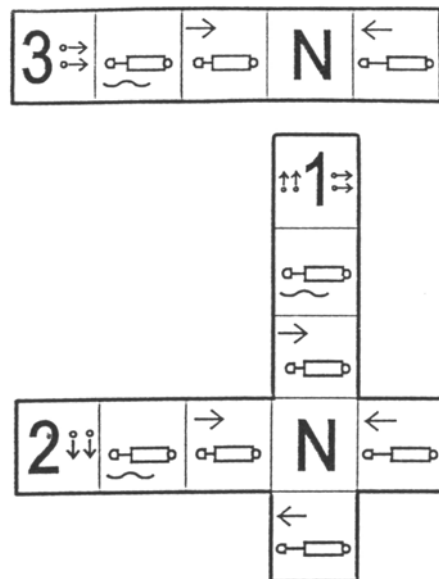
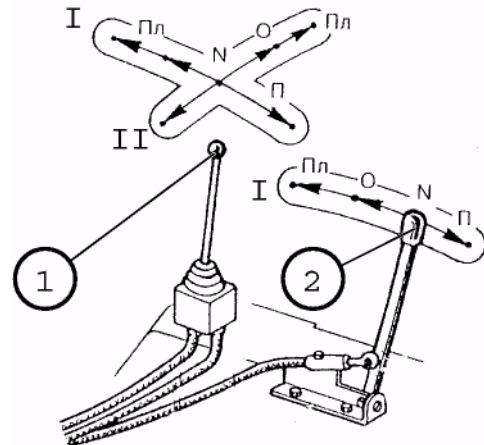

Control of the power/position governor of the hydraulic system

The control is performed by means of the lever (1). The control method, either power or position shall be previously set.

The lever (1) has the following positions:

- “N” – “Neutral” (fixed position);
- “Lifting” – rearmost position (non-fixed). Hold the lever with the hand to lift the implement to the required height. After releasing, it returns back to “Neutral”;
- “Automatic control range” (control zone) – between the “Neutral” and “Lowering” positions. Beginning the lowering of the implement corresponds to the control zone onset (minimum cultivation depth). The control zone end corresponds to the maximum cultivation depth;
- “Lowering” – foremost position (non-fixed). Hold the lever to lower the implement to the required level. After releasing the lever, it returns to control zone end.

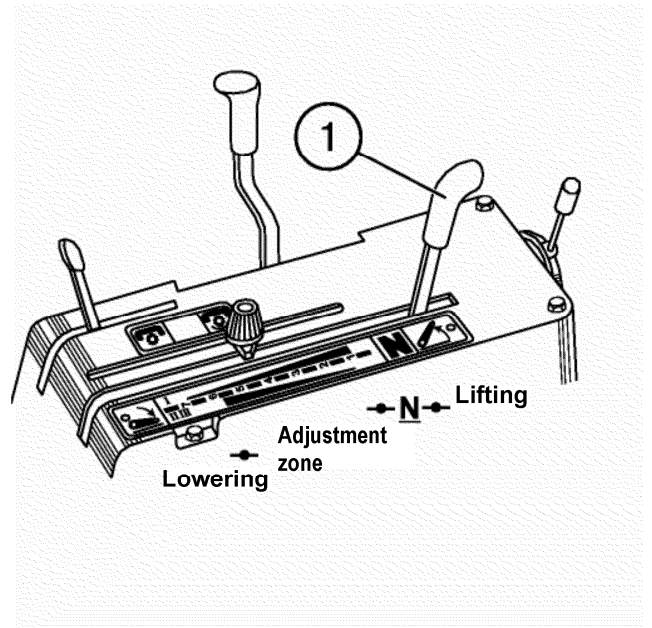

NOTE: If any of the distributor levers is set to the “Lifting” or “Lowering” position, the power governor operation in automatic control, lifting or lowering modes is interrupted.

Switch of power and position control methods (1)

To get access to the switch, remove the cover under the seat. The switch has the following positions:

- “N” – OFF;
- “I” – Power control;
- “II” – Position control.

Correction rate governor (2)

To reduce the implement position correction rate, turn the hand wheel (2) clockwise until jerks transferred during correction to the tractor are stopped.

ATTENTION! Prior to setting the lever to the selected position, lift the RMA to the uppermost position

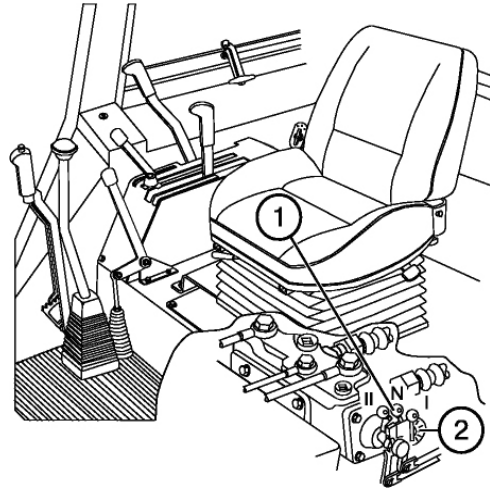

RMA hydraulic lift control

The hydraulic lift is controlled by means of two levers (1, 2) located on the board in the cab at operator's right hand.

The power control arm (1) is located close to operator and has the following positions:

Rightmost: maximum tillage depth (digit "9" on the board);

Rearmost: minimum tillage depth (digit "1" on the board);

Full control range of the soil cultivation depth: from "1" to "9".

Position control lever (2) has the following positions:

Foremost: minimal height of the implement above the soil surface (digit "9" on the board);

Rearmost: transport position (digit "1" on the board);

The maximum height of lifting the implement by the position control lever is provided by the adjustable stop (3).

NOTE: The combined control is provided by limiting the tillage depth with the position control lever in the mode of power control by means of the lever (1).

IMPORTANT! If any of the distributor control handle is set to the "Lift" or "Lowering" position, the hydraulic lift control by means of the levers (1, 2) is automatically ceased.

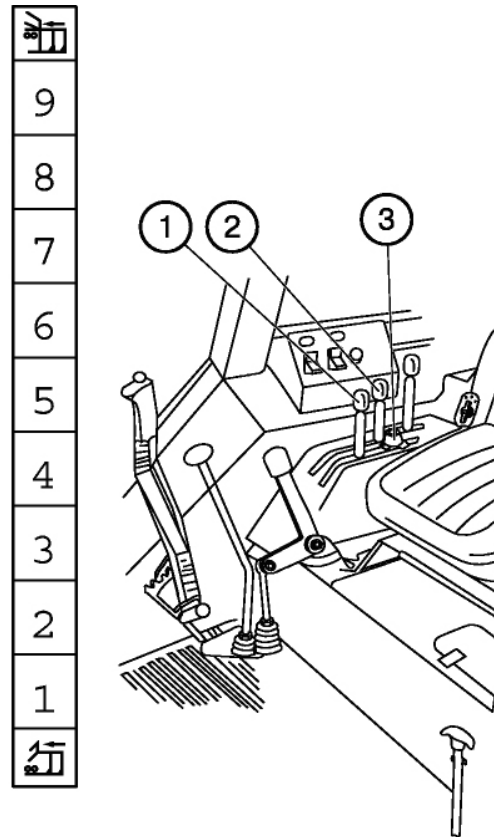

Compressor control

The handle (1) has two positions:

- “Compressor ON” – when turning the handle so that the arrow on the arm would be directed backwards with respect to tractor motion;
- “Compressor OFF” – when turning the handle to 180° so that the arrow would be directed forward with respect to tractor motion.

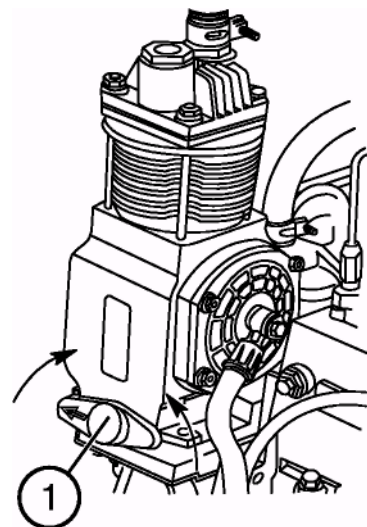

Changing the steering wheel position

To change the position of the steering wheel by height:

- Remove the cover (2);
- Unscrew the clamp (1) by 3...5 turns;
- Move the wheel to the required position;
- Tighten the clamp (1) by hand and refit the cover (2).

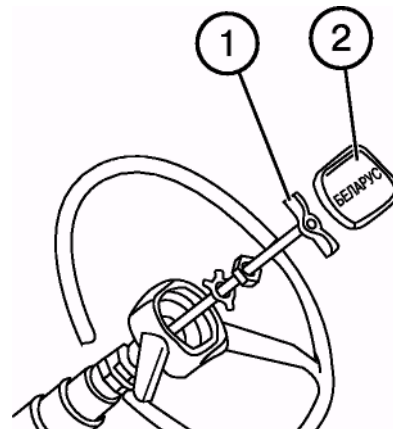

NOTE: The steering wheel adjustment range by height is 100 mm.

The steering column can be inclined to four different positions from 25° to 40° with the step of 5°. To incline the steering column, pull the rod (3).

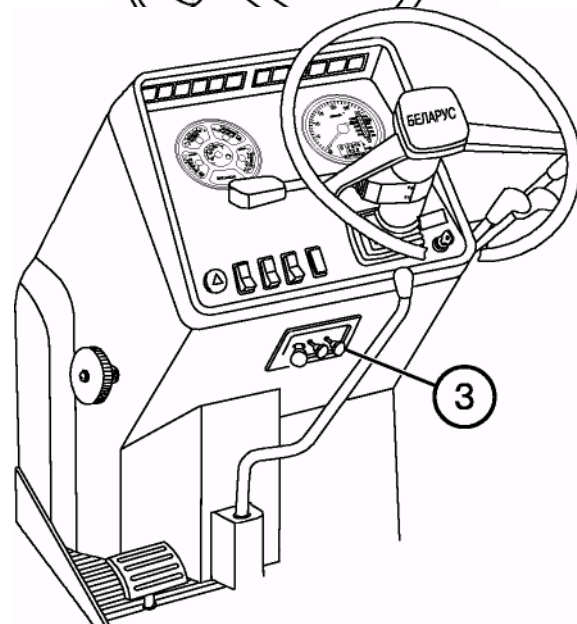

Cab heater control

When switching the heater on, ensure that the following conditions are met:

1. After filling the cooling system, start the engine and let it work at a medium rotational speed to heat water to the temperature of $+50^{\circ}\text{C} \dots +60^{\circ}\text{C}$, after which open the valve (1), increase the engine rotational speed and after 1-2 min make sure that the cooling fluid circulates through the heat exchanger by opening slightly the drain valve cap (5) on the cab right side. The heat exchanger shall start warming-up. Then the cooling fluid level in the engine cooling system radiator will decrease.

2. Add cooling fluid into the radiator to the required level (50...60 mm below the upper edge of the filler neck).

3. Turn the heater fan on by means of the switch (3) and direct the air flow by means of air distributors (4).

4. The flow of fresh air delivered to the cab can be controlled by opening the recirculation flaps (2).

To drain the cooling fluid from the heating system, the drain plugs (5) are provided on the right and left sides of the cab. After draining the cooling fluid, it is necessary to blow out the system, having closed preliminary the valve on the cylinder block and unscrewed the plugs (5). After blowing-out, tighten the plugs.

NOTE: The valve shall be closed to operate the system in the ventilation mode during warm season.

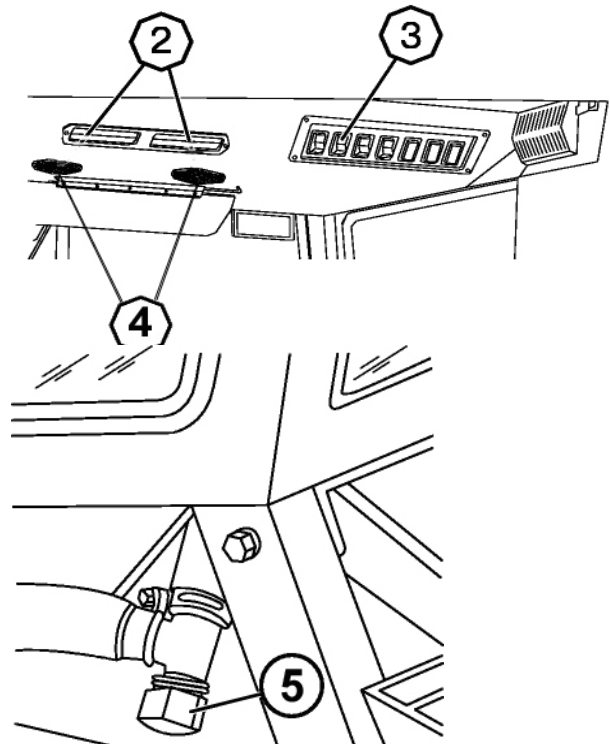
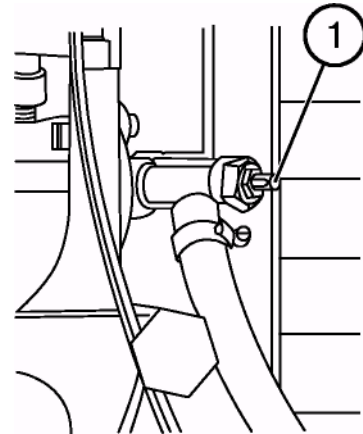

Belarus Seat

The seat is provided with mechanical suspension consisting of two spiral torsion springs and a gas-filled two-way shock absorber. Shear-type guiding mechanism ensures strictly the vertical displacement of the seat. Dynamic motion of the seat is 100 mm.

The seat has the following controls:

1. Adjustment by operator's weight within the range from 50 to 120 kg with indication of the suspension travel middle position. Turn the handle (1) clockwise (as seen from the operator's seat) to adjust the seat to larger weight and vice versa.
2. Transverse adjustment within ± 80 mm from middle position. Lift the lever (2) upwards to the stop and move the seat forward or backward to comfortable position.
3. Back inclination adjustment within the range from 5° to 25° . Lift the arm (3) upwards to the stop, turn the back and release the arm. The back will be fixed in the given position.

The seat can be adjusted by height within ± 30 mm by moving consequently it manually upwards to increase the height. To decrease the seat height, lift it abruptly upwards to the stop and then push it down.

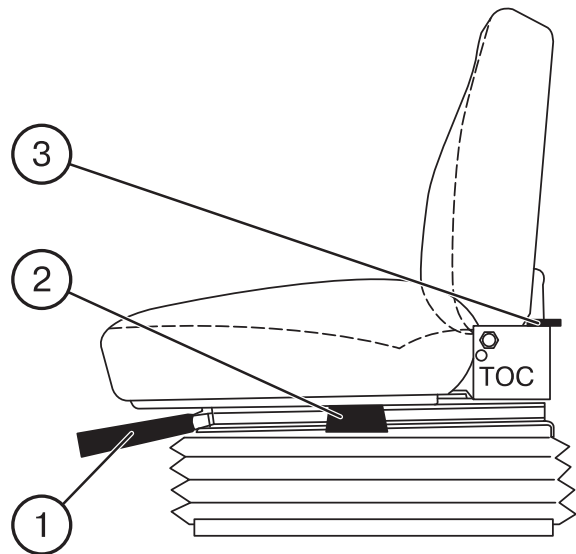

Grammer Seat (if installed)

Important! Prior to beginning the operation of the tractor, adjust the seat to the position being the most convenient for you. Perform all the adjustments while sitting on the seat.

The seat is provided with mechanical suspension having the total travel of 100 mm and hydraulic shock absorber protected by a rubber boot. The armrests being adjustable to height and safety belts are standard.

The seat is equipped with the following controls (handles):

1. Back inclination: to 12.5° forward and 5° backward with the step of 2.5° .
2. Weight indicator.
3. Weight control: from 50 to 130 kg steplessly.
4. Forward/backward motions: within the range of 150 mm with the step of 15 mm.

The adjustment of the seat height within 60 mm is provided in three positions. To set the required height, pull the seat upwards. The indicator click determines a new position. Should the seat be pulled upwards from the uppermost position, the lowering mechanism will operate and the seat will be lowered to the lowermost position.

Note: Do not use solvents for cleaning the seat upholstery. Use only warm water with small amount of detergent.

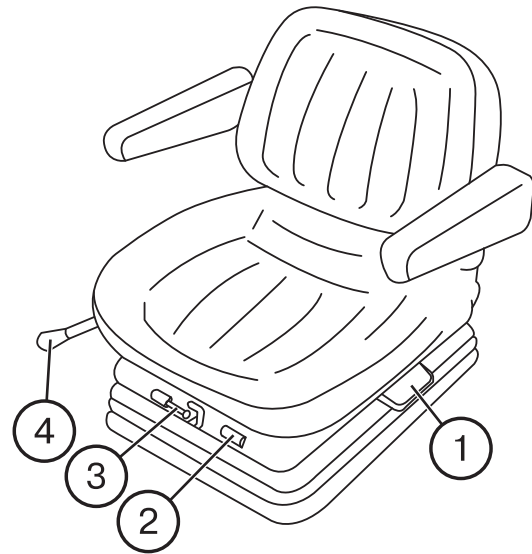

OPERATING INSTRUCTIONS

Tractor pre-operation

When preparing a new tractor for operation, re-activate it: To do this:

- remove protective covers and plugs fitted on the engine;
- install peacocks of the radiator and cylinder block;
- fill in all the refill tanks;
- unpack the silencer put in the cab and fit it onto the exhaust manifold so that exhaust pipe outlet cut would be directed forward along the tractor motion. Install the retaining clip at the distance of 8...12 mm from the silencer branch end. Tighten the clip nuts with the torque of 44...54 Nm;
- drain the sediment from the coarse and fine fuel filters and fuel tank;
- fill the fuel supply system with fuel and bleed the system to remove air from it;
- check the fan belt tension;
- check and adjust the air pressure in the tyres;
- make the service of the storage battery;
- tighten the fasteners;
- grease all the lubrication points using a gun;
- check and adjust, if necessary, the front wheel toe-in.

WARNING! To avoid injuries, make sure that all protective guards are in their places prior to starting the diesel engine.

ATTENTION! Starting a new engine, which is not run-in, by towing is not allowed to avoid the intense wear of the engine parts.

Running-in

Your new tractor will work reliably and for long time, provided that running-in is made properly and necessary maintenance is provided within the recommended terms. When executing the 30-hour running-in, observe the following rules:

1. Watch constantly the instrument readings and operation of lubricating, cooling and feed systems. Monitor the oil and fluid levels in refill tanks.
2. Check the tightening and retighten the external fastening junctions.
3. Run in the tractor on light transport and field works (harrowing, cultivation, sowing, etc.), gradually increasing the load at different gears.
4. Do not overload the engine, do not allow fuming or drop of the rotational speed. The overload symptoms are abrupt drop of the rotational speed, fuming and failure to respond to higher fuel feed.
5. The operation of the tractor at very low gear with small load at high rotational speed of the engine will result in excessive fuel consumption. The correct gear selection for each particular work provides the fuel saving and reduces the engine wear.
6. Regularly perform time-shift maintenance in accordance with recommendations stated in this Manual.
7. After running-in the tractor, perform the maintenance works (see Section "Maintenance").

Starting the engine

Starting under normal conditions:

Check the level of oil in the crankcase and of cooling fluid in the radiator and the presence of fuel in the tank.

IMPORTANT! Never start the engine with the empty cooling system!

IMPORTANT! Start the engine and check the instrument operation while sitting in the operator's seat only.

WARNING: Never operate with tractor indoors.

IMPORTANT! The BELARUS-900.3/920.3/950/950.3/952/952.2/952.3 tractors are equipped with turbocharged diesel engine. High rotational speeds of the turbocharger require the reliable lubrication when starting the engine. Therefore prior to first starting or after long-term storage, rotate the crankshaft by the starter for 10 s without fuel supply to lubricate the turbocharger bearings. Prior to loading the engine, let it run idle for 2...3 min.

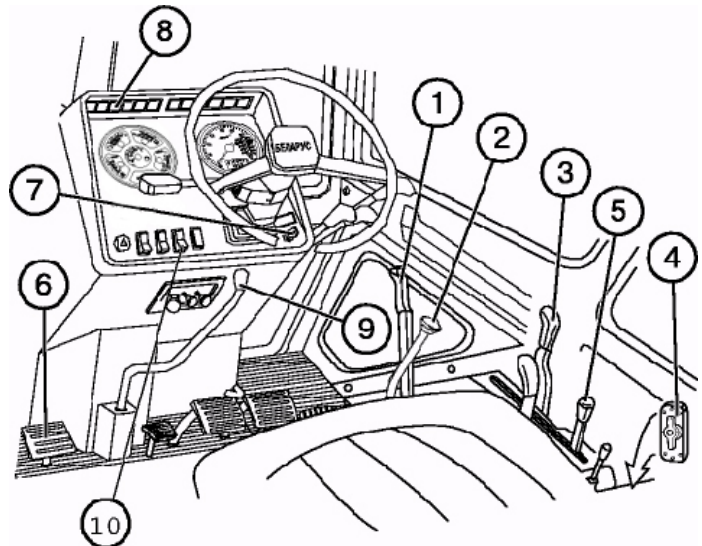

1. Apply parking brake (1);
2. Set the change gear lever (2) to neutral position, move it to the leftmost position and hold it in this position until the start is completed and the step-down reducing gear lever (9) to the extreme position (back or front);
3. Set the PTO lever (3) to the OFF position and the "Synchronous-Independent" switching lever – to the "Neutral" position;
4. Set the ground switch (4) to the ON position;
5. Set the fuel feed arm (5) to the middle position;
6. Step on the clutch pedal (6);
7. Turn starter key (7) to the position II (Start) and hold it until the engine is started, but not more than 15 s. Then the start control light in the pilot lamp block unit (8) will light up. When the engine starts running, the light shall become dim. If the engine fails to start, repeat starting after at least 30...40 s.

start locking circuit. If the light blinks at high frequency (about 3 Hz), there is a failure in the alternator circuit (terminal "W" or "~").

8. Release the clutch pedal (6). After starting the engine, check the operation of all indicating lamps and instrument readings (cooling fluid temperature, oil pressure in the engine and storage battery charge). Let the engine run at 1000 rpm to stabilize the oil pressure in the operating range.

ATTENTION! If the starter fails to operate and the pilot lamp of the starter control board blinks at low frequency (about 1.5 Hz), this indicates that the change gear lever is not in neutral position or there is a breakage in the

Starting at low temperatures (+4°C and below)

Important! To avoid the damage of the power gear, do not push or pull the tractor to start the engine by towing.

The engines of the BELARUS-900.3/920.3/950.3/952.3 tractors are equipped with glow plugs. When energizing them, the plugs get red-hot and heat the air taken into each engine cylinder.

At steadily low temperatures, use the winter oil grades in the engine crankcase, gear box and hydraulic system in accordance with the recommendations of this Manual.

Keep storage batteries always charged.

Use pure winter diesel fuel not contaminated with water.

To avoid failures, drain sediments from the coarse fuel filter and fuel tanks every day.

Attention! If the tractor is equipped with electric torch pre-heater, use previously published "Operating instructions".

Procedure of starting the engine at low temperatures:

- Switch off the hydraulic system oil pump drive to reduce the resistance to the crankshaft turning;
- Check the level of oil in the engine pan and of cooling fluid in the radiator;
- Apply the parking brake to keep the tractor from motion;
- Set the change gear lever and the range lever (2) to the neutral position, move it to the leftmost position and hold it in this position until the start is completed and the step-down reducing gear lever to the extreme position;

- Set the PTO control lever (3) to the OFF position and the "Synchronous-Independent" switching lever – to the "Neutral" position;
- Set the ground switch to the ON position;
- Set fuel feed control arm (5) to the mid position;
- Step on the clutch pedal;
- Hold the key in the "I" position for more than 2 s. Then the starting aid warning lamp will light up at the pilot lamp block, signalling about the glow plugs energizing. Hold the key in this position. As soon as the warning lamp starts blinking at the frequency of 1 Hz, the glow plugs and the engine are ready for starting;
- Turn the starter key to the "II" position and start the engine under normal conditions as stated above. After starting the engine, the pilot lamp will become dim and audible warning will be silenced.

Note: The system ensures the operation of the glow plug within 3 minutes after starting the engine (then the pilot lamp is off).

Attention! If the glow plug pilot lamp lights up in the blinking mode at the frequency of 2 Hz after starting the engine and operation within 3 minutes, this indicates that the glow plugs are not switched off after finalization of the full cycle by the system. Shut down the engine, turn the ground switch off and eliminate the failure. A probable reason can consist in sticking the electromagnetic relay contacts.

- Release the clutch pedal. Warm up the engine.

Starting the tractor motion

ATTENTION! When selecting the required gear, use the gearbox switching diagram.

To start the movement, proceed as follows:

- step on the clutch pedal fully;
- select the required gearbox range;
- shift the lever (1) to the leftmost position and set the range II or I, respectively, by moving the lever forward or backward;
- return the lever to the neutral position and then to the right, select the required gear and set the required speed by moving the lever (1) forward or backward;
- set the lever 2 to the required extreme position (forward or backward)*.

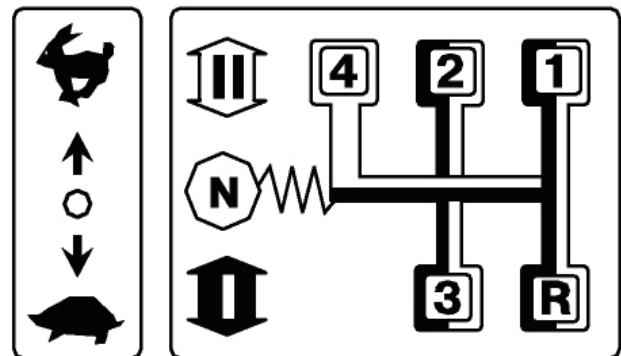
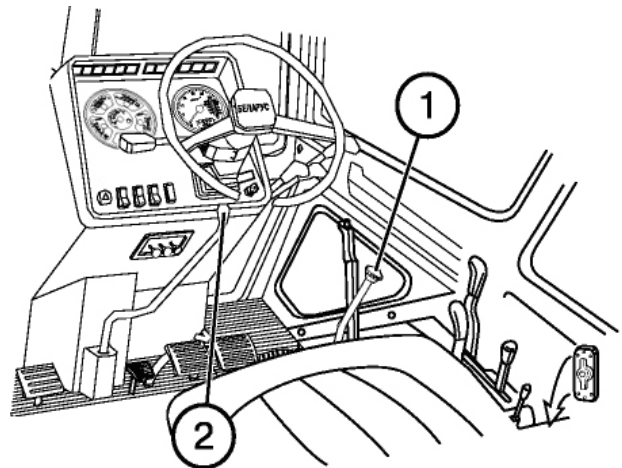

Release the parking brake and release smoothly the clutch pedal while increasing slightly the fuel feed. On starting the motion, increase the fuel feed.

Avoid starting the motion with high traction load (e.g. a plough deepened into the soil).

ATTENTION! Always step on the clutch pedal prior to engaging the range (step) and putting in the gear. Do not hold the foot on the clutch pedal during operation on the tractor, since this can lead to clutch slipping, its overheating and failure.

* Forward – direct gear, back – reducing the speed for tractors with reducing gear and increasing the speed for tractors with multiplier.

Stopping the tractor

To stop the tractor:

- Reduce the engine crankshaft speed;
- Step on the clutch pedal;
- Set the change gear lever to neutral position;
- Stop the tractor by applying the service brakes;
- Apply the parking brake.

IMPORTANT! To stop the tractor in case of emergency, step on the clutch pedal and twinned service brakes pedal at the same time.

Shutting down the engine

IMPORTANT! Prior to shutting down the engine, lower the implement onto the ground and let the engine operate at 1000 rpm within 1...2 min. This will decrease engine temperature.

To shut down the engine, proceed as follows:

- set manual fuel feed arm to minimal feed position (back to the stop);
- disengage the PTO and set all the distributor's levers to neutral position;
- lower the implement onto the ground;
- pull engine shut-off lever cord handle to fully stop the engine;
- turn ground switch off to avoid storage battery run-down.

Steering control

IMPORTANT! The tractors are equipped with the hydrostatic power steering system. If the engine is stopped, the pump does not supply the system and it begins automatically operating in the manual mode where turning the tractor requires applying more force to be applied to the steering wheel.

Switching over the transmission with a shuttle gear (if installed)

Switch the gearbox and the shuttle gear in accordance with the changeover scheme. Using the tractor in the “shuttle” mode makes it possible to change quickly the direction of the tractor motion by means of the lever (2) without using the change gear lever (1).

The shuttle gear control lever (2) is located under the steering column (unlike the reducing gear lever, it is bent to the left) and has two positions:

- “Reverse OFF” – foremost position;
- “Reverse ON” – rearmost position.

IMPORTANT! When changing motion direction, step on the clutch pedal and stop the tractor.

NOTE: When the shuttle gear is engaged and the change gear lever (1) is set to the gear I-R and II-R, the tractor moves forward.

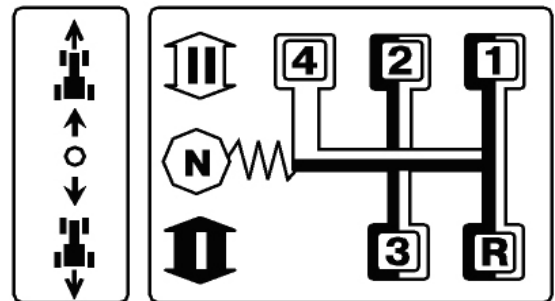
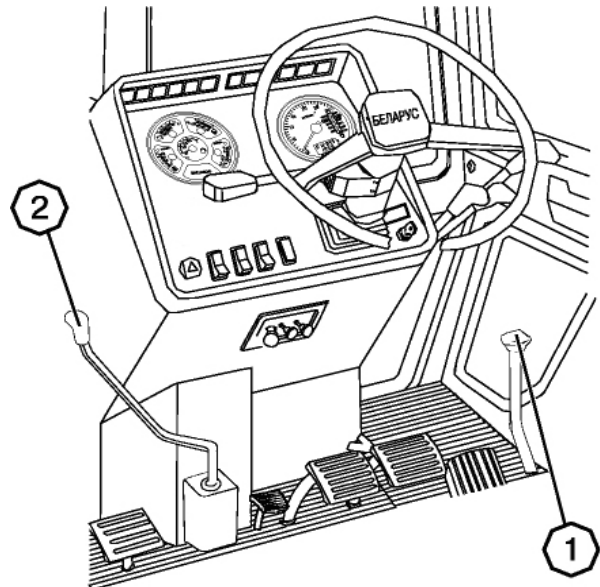

Operation of the tractor equipped with a speed reducer (optional)

1. Set the change gear lever (4) to neutral position and reducing gear lever (1) to foremost or rearmost positions.
2. Set the speed reducer controls as follows:

- gear handle (2) to the "ON" position;
- range rod (3) to the "N" position (neutral).

To start the tractor motion:

1. Set the minimum idling speed of the engine.
2. Step on the clutch pedal.
3. Set the speed reducer gear handle from position ON to neutral.
4. Select the required speed reducer gear.
5. Set the required speed reducer range.

ATTENTION! It is forbidden to put in the 2nd gear of the speed reducer range II at the 2nd gearbox reverse gear.

6. Put in the required gear of the gearbox in the range I.
7. Release smoothly the clutch pedal. If necessary, increase fuel feed.
8. Adjust the tractor speed by varying fuel feed.

Speed reducer gear switching

1. Set the minimum engine idling speed.
2. Step on the clutch pedal.

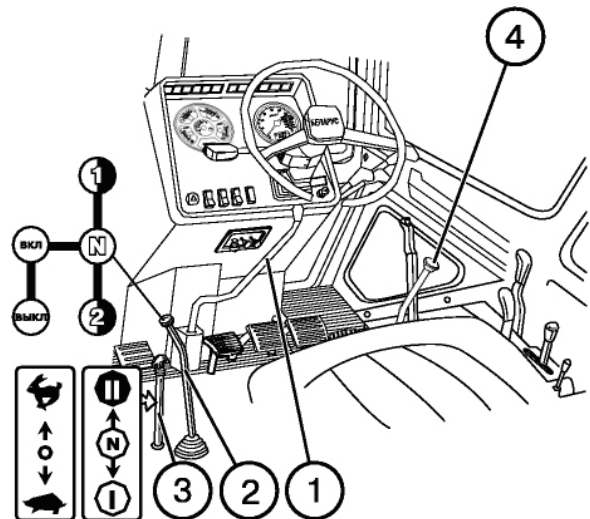

3. Wait for 3...5 s and then set the change gear lever to the neutral position.
4. Put in the required speed reducer drive.
5. Put in the 1st gear of the gearbox.
6. Release smoothly the clutch pedal.
7. Adjust the speed by the foot-operated or manual fuel feed control.

Stopping the tractor

1. Set the minimum engine idling speed
2. Step on the clutch pedal.
3. Wait for 3...5 s and then set the change gear lever to neutral position.
4. Stop the tractor by applying the service brakes. Apply the parking brake.

Hydraulic system

The hydraulic system for three-point rear attachment control is equipped with power governor*, which ensures system operation in the following modes:

- power control;
- position control;
- height control.

Power and position control

The power/position control makes the system sensitive to variation of operating conditions. Effective application of these modes depends on the unitized machines and land conditions.

Position control

It provides the accurate and sensitive monitoring of the position of the attached equipment like spraying machine, leveller and others above the ground. The position control can be used with the tillage machines, semi-hookup ploughs with external cylinders, etc. However, it is not recommended to use this control on uneven fields when using the tillage machines and implements.

Hydraulic lift (if installed)

The HMS with hydraulic lift provides for operation in the following modes:

- lifting the RMA and lowering it under its own weight;
- position control;
- power control;
- combined control (adjusting the cultivation depth according to the soil condition with limiting the maximum depth by the position control).

Power control

It is the most suitable mode for operation with mounted implements, the working parts of which are deepened into the soil. The system is sensitive to traction effort variation (caused by the changes in the soil resistance or soil tillage depth) via central rod of the hitch mechanism. The hydraulic system responds to these changes by lifting or lowering the implement to maintain the given tractive force at constant level. The system reacts to the compressing and stretching forces in the central rod, i.e. is a dual-action system.

Height control

When tilling the soil with greatly varying density and resistance, and uneven surface, if the **power** or **position control** does not ensure satisfactory tillage quality according to land treatment requirements, it is recommended to use the **height** control (using the implements with supporting wheels).

* The Belarus tractors with index “.2” are equipped with RMA hydraulic lift and do not have power governor

Working equipment to attach agricultural machines to the tractor
(for tractors with power governor)

ATTENTION! Prior to attaching the machines read carefully this section.

Rear three-point mounted attachment: to join mounted and semi-mounted agricultural machines – ploughs, seeders, cultivators, spraying machines, etc.

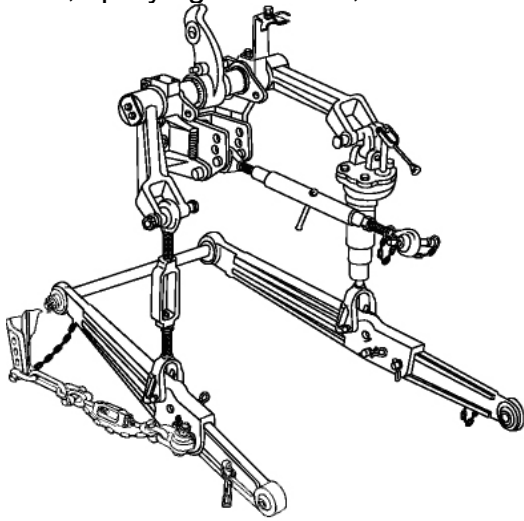

Traction hitch mechanism (cross-bar) TCY-1Ж: to work with trailing machines, potato combines and others (except single-axle ones) with the speed of up to 15 km/h.

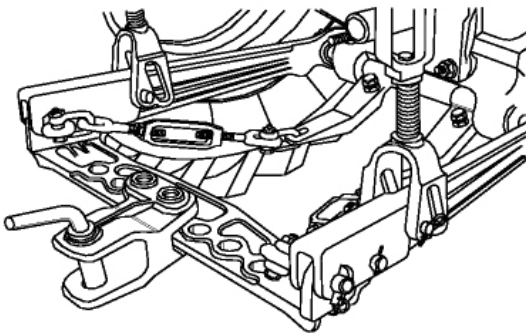

ATTENTION! Using the TCY-1Ж when performing the transportation works is strictly forbidden.

Traction hitch mechanism TCY-2 (hydraulic hook): to operate single-axle trailers and other machines.

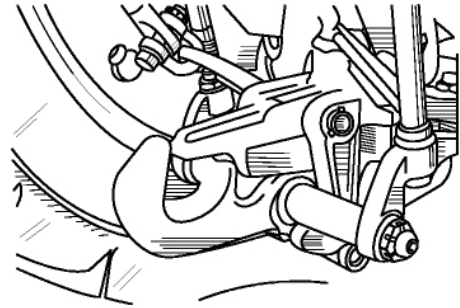

Traction hitch mechanism TCY-1M (floating lever): to operate with heavy trailing machines (optional). A combined variant with a hook for working with the semitrailers.

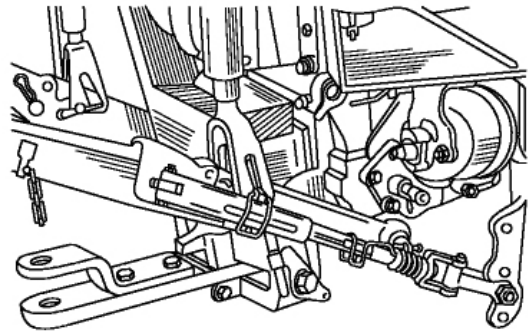

Traction hitch mechanism TCY-3K (trailer gear with automatic hitch): to operate two-axle trailers.

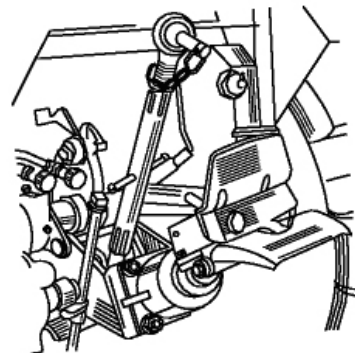

Rear mounted attachment (HMS with power governor)

The second-category three-point mounted attachment ensures the connection of mounted and semi-mounted agricultural machines and implements to the tractor with the following attachment components:

- hanger axle length "L" (distance between joints "A" and "B") is equal to 870 mm;
- machine support height is 460 mm; 510 mm;
- pin diameter to connect to lower rod joints (1) is 28.7 mm;
- pin diameter to connect to upper rod (2) is 25 mm.

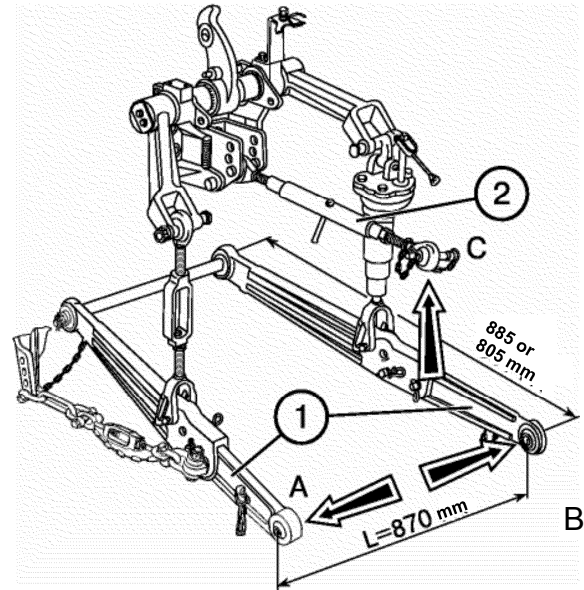

The lower rods consist of two parts:

- front part or rod itself;
- rear end with the ball joints. Standard length of the low rod: 885 mm.

To increase the hanger length, install the rod ends with deflected front joints ($\Phi 70-4605050-01/055-01$).

To increase the load-carrying capacity of the mounted unit, replace the rear rod ends (400 mm long) by the rod ends having the distance of 320 mm between the joint axis and the front aperture (H50-4605040A2/045A2). Total lower rod length will become 805 mm.

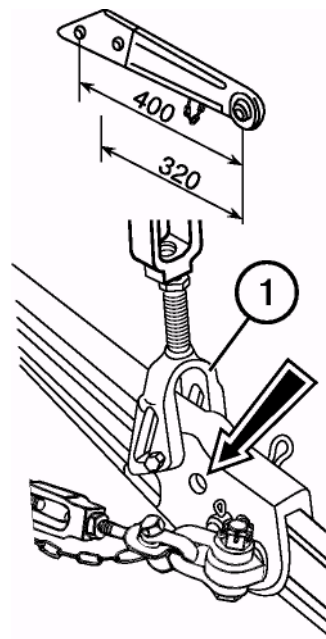

ATTENTION! When the rod length is 805 mm, the carrying capacity of the mounted unit will be increased by 10% with decreasing the lifting height by 10%. The same load-carrying capacity can be ensured by installing the angle brace (1) at the additional points (the lifting height will be also decreased by 10%).

To increase the clearance when cultivating the high-stem crops, install the front ends of the lower rods onto the additional hanger axles located at the distance of 110 mm above the lower rod axis. To imitate field profile crosswise when operating wide-cut implements, connect the angle braces (1) with lower rods (2) via longitudinal grooves.

IMPORTANT! To avoid the damage of the angle brace, the angle brace fork grooves shall be behind the aperture.

Upper rod and angle braces

The upper rod length is adjusted within 500...740 mm. The length of the right adjustable angle brace can be adjusted within 425...520 mm by rotating the handle (1). When being shipped from the factory, the right angle brace length is set to the standard value of 475 mm. When the tractor is shipped from the factory, the left (non adjustable) angle brace length is set to standard 475 mm.

During operation, the left angle brace length can be changed within 395...510 mm, depending on the standard equipment of the tractor and type of unitized machines and implements.

IMPORTANT! Make adjustment of the implement laterally with the right angle brace only.

Depending on the tillage depth and soil nature, install upper rod to one of the three* positions:

- I – light soils and small tillage depth at power control;
- II – medium soils and medium tillage depth at power control;
- III – heavy soils at large tillage depth, as well as at position control or without power governor.

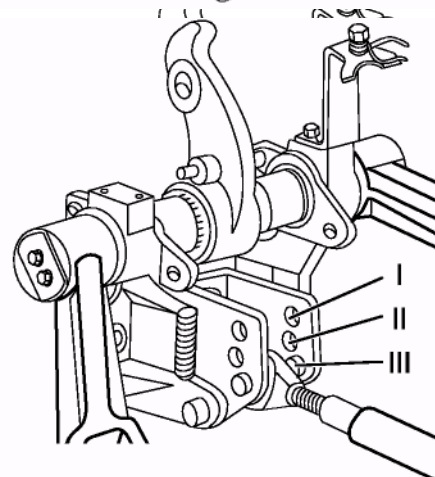
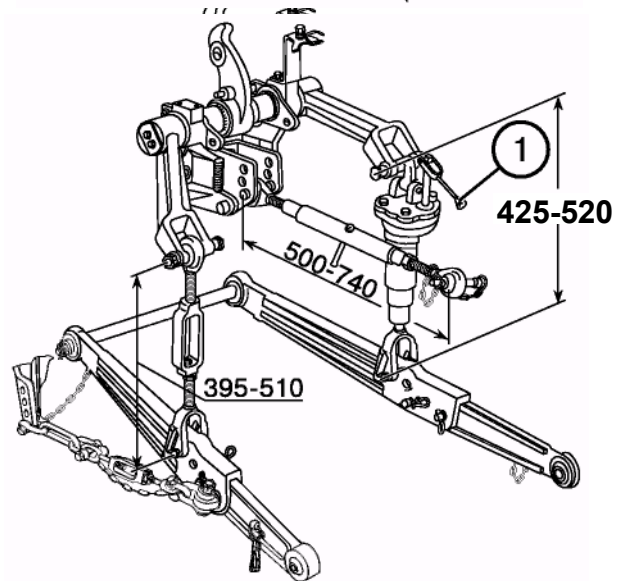
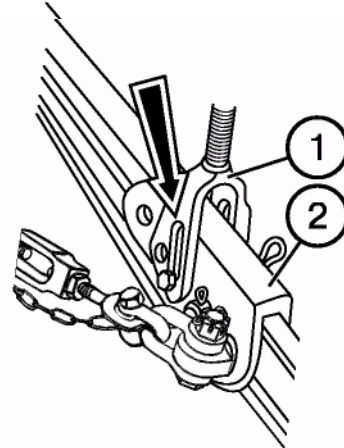
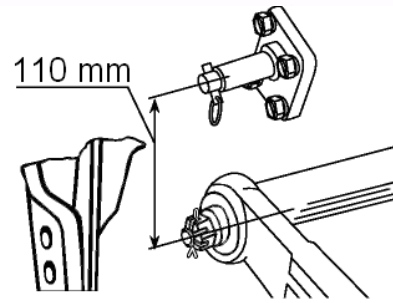

* For tractors equipped with HMS with hydraulic lift, the upper rod is installed in one position.

Reinforced rear mounted attachment

The tractors with power governors may be equipped optionally with a reinforced rear mounted attachment with telescopic lower rods, which are to be installed onto the shaft with the diameter of 35 mm instead of that with the diameter of 32 mm. If necessary, the length of the rods equal to 885 mm may be adjusted stepwise with the step of ± 80 mm, in this case, the carrying capacity of the mounted attachment will be varied.

For working with trailed agricultural machines, the double cross-bar (4) for the lower telescopic rods (1) with the pivot (5) is optionally delivered. In this case, its tips (3) are fitted instead of the rear ends of the rods (2). The distance from the end face of the PTO to the pivot (hitching point) in such version will be 470 mm

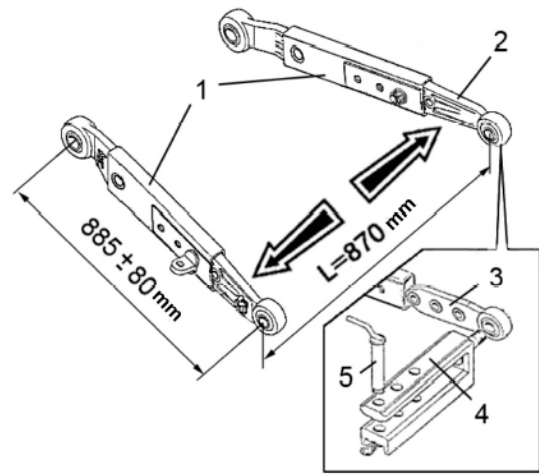

ATTENTION! It is strictly forbidden to use the double cross-bar when performing the transportation works.

Rear mounted attachment of the tractors equipped with the hydraulic lift

Machines: mounted (ploughs, cultivators, seeders, cutters, etc.), semi-mounted (ploughs, soil-tilling units, seeders, potato combines, etc).

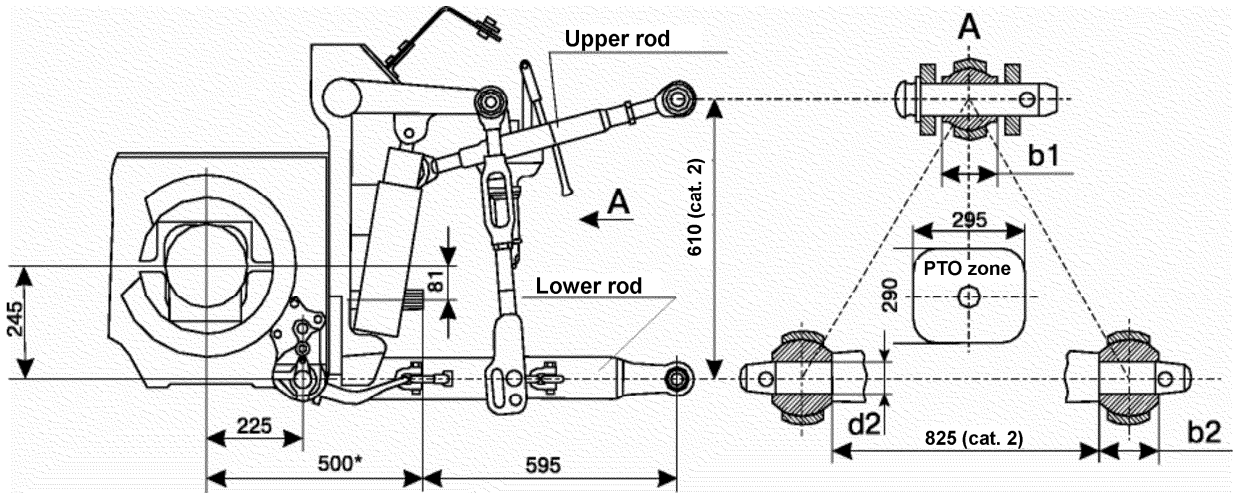

Lower rods	Telescopic, one-piece - optional
Length of lower rods, mm: telescopic one-piece*	805,885,985 885
Rod joint width, mm: upper (b1) lower** (b2)	51 38 or 45
Nominal diameter of attachment components, mm: upper rod pin** lower rod joints (d2)	22 or 25 28
Distance from PTO face to hanger axle	595
Load carrying capacity, kN (kgf): on hanger axle on 610 mm overhang	43 (4300) 27 (2700)

* Optional – rods with quickly connectable attachment

** (Quickly connectable attachment). To be agreed when acquiring the tractor.

Traction hitch mechanisms (THM) of the tractors equipped with hydraulic lift

TCY-1Ж-01 (double cross-bar)

TCY-1* (single cross-bar)

Machines: semi-mounted (seeders, potato-planters, potato combines, vegetable-harvesting machines, etc.), semi-trailer (mowing machines, balers, haulm gatherers, etc.).

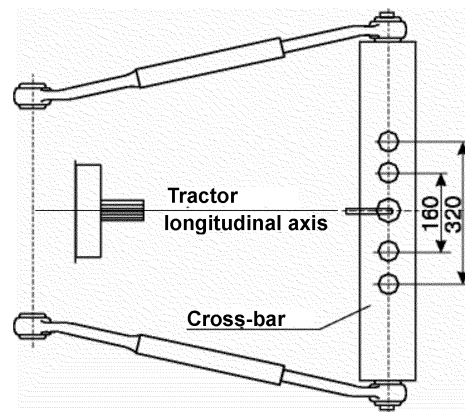
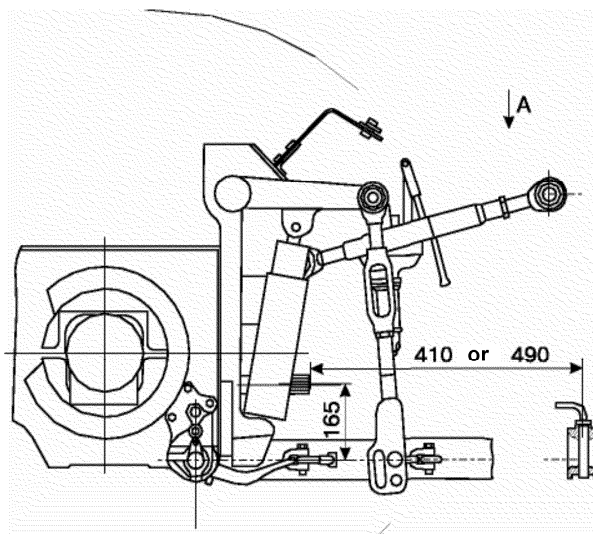

TCY-1Ж-01 (double cross-bar)	as a unit with telescopic rods – optional	
TCY-1 (single cross-bar)	with one-piece or telescopic rods on hanger axle – optional	
Telescopic rod front end length	mm	570
Distance between PTO face to attachment pin axle	mm	410,490,595*
Attachment pin size	mm	030 (0 30)
Vertical load on THM	kN (kg f)	12(1200) 6, 5* (650)*
Machine turning angle relative to the tractor	degree	± 65 (± 80)

* Indices are given for TCY-1

Г15 Lifting THM of the tractors equipped with hydraulic lift

1.TCY-2B (fork)

Machines: semi-trailed (semi-trailers, machines for fertilizing, etc.), trailed (disk harrows, tillers, hoeing ploughs, hitch of harrows, cultivators and seeders, etc.).

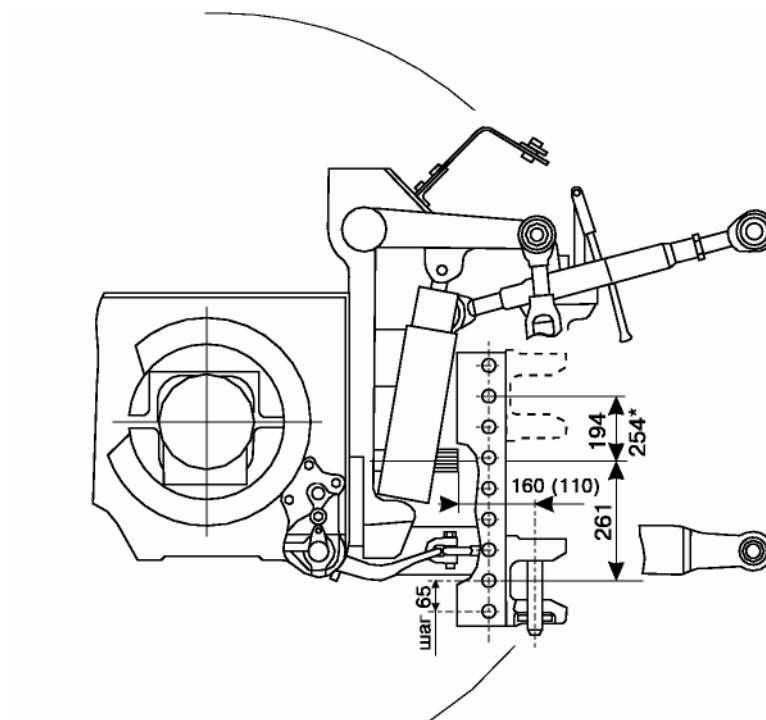

Hitch mechanism	Fork with the possibility of the vertical displacement
Distance from the fork to supporting surface for machines without PTO drive, mm	403.. .858 (91 8*) stepwise via 65 mm
Fork position for machines with PTO drive	Lowermost or uppermost
Distance from PTO face to attachment pin axle, mm	160 or 110
Attachment pin diameter	40
Vertical load on THM, kN (kg f)	20 (2000)
Machine turning angle relative to the tractor, degree	±65

* With turning over the fork

2. TCY-3B (fork)

Machines: trailed (automobile-type two-axle trailers, etc), semi-trailed (same as for TCY-1Ж-01).

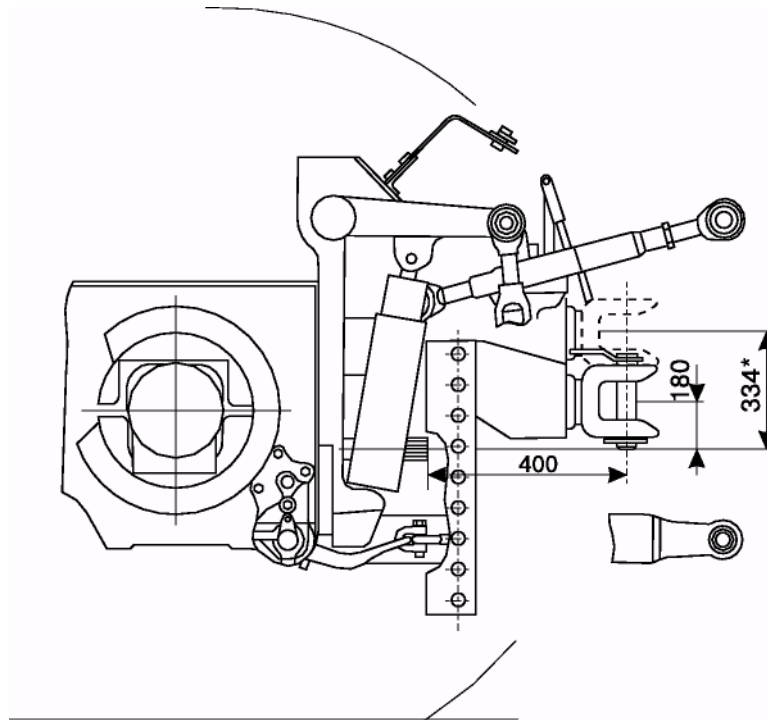

Hitch mechanism		Rotating fork with vertical displacement
Distance from the fork to supporting surface for machines without PTO drive, mm	mm	288.. .808 (962*) stepwise via 65 mm
Fork position for machines with PTO drive		lowermost or uppermost, including overturn
Attachment pin size	mm	040
Distance from PTO face to attachment pin axle, mm	mm	400
Vertical load on THM	kN (kg f)	12 (1200)
Machine turning angle relative to the tractor	degree	± 55 (trailers), ± 85 (agricultural machines)

* With turning over the fork

Г17 3. TCY-1M (dragbar)

Machines: heavy trailed with active drive of driven elements.

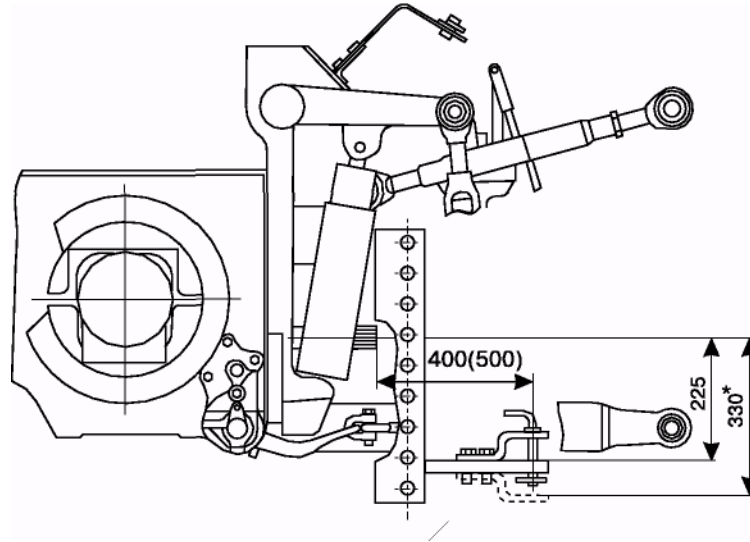

Hitch mechanism	Fork with variation of position relative to PTO face
Distance from the fork to supporting surface, mm	402 (297*)
Distance from PTO face to attachment pin axle, mm	400 or 500
Attachment pin diameter, mm	30
Vertical load on THM, kN (kg f)	12 (1200)
Machine turning angle relative to the tractor, degree	±85

Hitching machines to the tractor

1. When hitching machines to the tractor, make sure first that there is nobody within hitching zone.
2. Lower the attached device to the lower position by using the power governor handle, drive the tractor back and attach the machine to lower rods. Splint the pins. Stop the engine.
3. Make the upper rod (1) longer or shorter and connect the rod ball joint with the machine. Splint the pin.
4. If necessary, adjust the upper rod to initial or required length.
5. If necessary, adjust the machine lateral tilt by using the right adjustable angle brace (2). Increase the angle brace length, turn arm (3) clockwise and vice versa.
6. Prior to operation, check that:
 - the tractor parts are not in dangerous proximity to machine components;
 - the central rod is not in contact with PTO enclosure at the lowest position of the machine;
 - the PTO cardan drive is not extremely long, with large joint angles and there are no thrust forces;
 - the PTO enclosure is not in contact with that of machine cardan drive.
7. Slowly lift the machine and check the clearance of at least 100 mm between the tractor and the machine in lifted position.
8. Check the lateral swing of lower rods and, if necessary, adjust them by using tie rods.

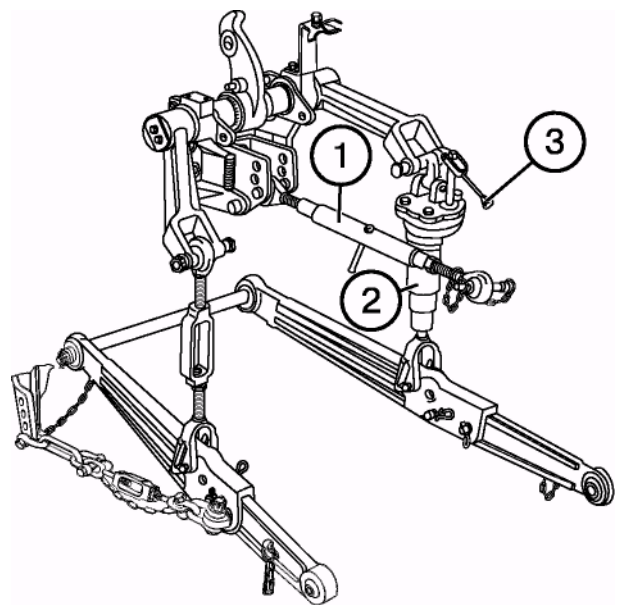

The machine (implement) is also attached to the tractor by the automatic hitch CA-1 connected to the tractor hookup at three points (two rear joints of longitudinal rods and rear joint of the central rod).

To prevent spontaneous disconnection of the machine from the tractor, fix the automatic hitch latch with a spring cotter pin.

Limiting (telescopic) tie bars (A)

The tie bars are used to limit lateral swinging of hanger lower rods both in transport and working states. This is especially required during the works on the slopes, near the excavation pits, wall, etc.

Rear end of the tie bar is attached to the lower rod and the front one – to the holder in one of four positions, depending on the works:

- Position 1. The tie bars exclude implement swinging in transport state.
- Position 2. The tie bars exclude implement lateral swinging both in transport and working states.

IMPORTANT! Positions 3 and 4 should be used only when installing lower rods onto additional axes of the hanger (upper axes).

- Position 3. The tie bars exclude implement lateral swinging in transport state.
- Position 4. The tie bars exclude implement lateral swinging both in transport and working state.

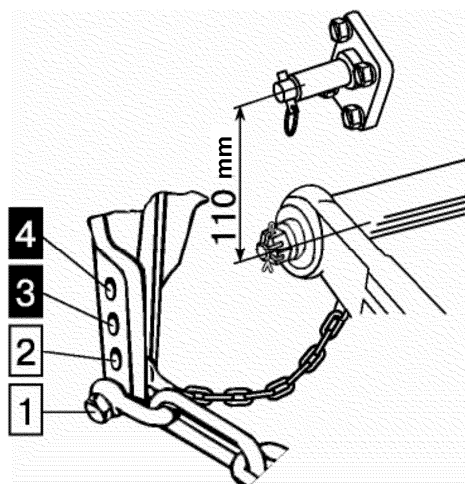
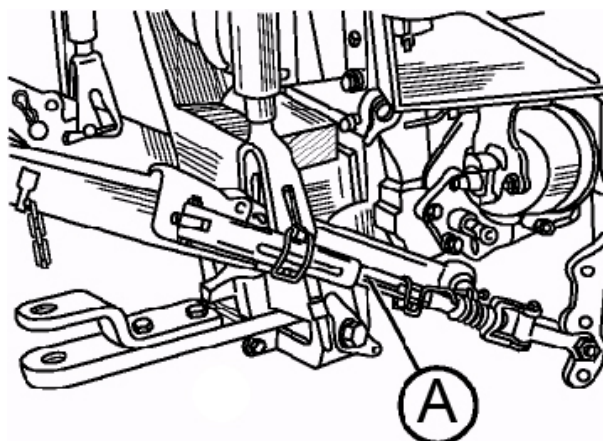

ATTENTION! The tie bars shall be installed only into the second from bottom apertures for holders (position 2) to avoid tie bar failure.

Partial locking of telescopic tie bars

To ensure the required lateral displacement of the machine, e.g., a plough, adjust the tie bars in the operating condition as follows:

- rotating the screw (2), set the handle (3) at the middle of flat "B";
- pull out the cotter (5) from the tie bar;
- attach the machine to the lower rods (7) and raise it a little to pull off the ground;
- having aligned the apertures of the internal tube (4) with the groove of external tube (6), insert the cotter (5) in the middle of the groove

IMPORTANT! Install the cotter (5) so that it is in the middle of the groove or at minimal displacement towards the tractor. Otherwise, tie bars can be damaged.

Prior to transportation, lift the machine to the up position and check its lateral swinging, which shall not exceed 20 mm in each direction. If necessary, adjust the swinging by rotating the screw (2).

Full tie bar locking

For complete locking of the machines, e.g. a cultivator or attached unit, adjust tie bars in the working state similar to their partial locking, except for the last operation during which align the aperture of the internal tube (4) with that of external tube (6) and insert the cotter (5).

Ensure full locking in transport state (the machine being lifted) by tightening screw (2) into tube (4) to the maximum.

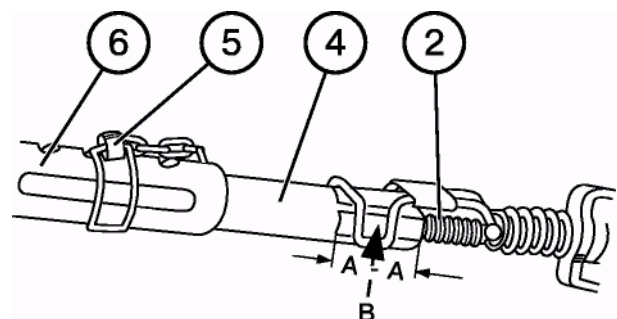
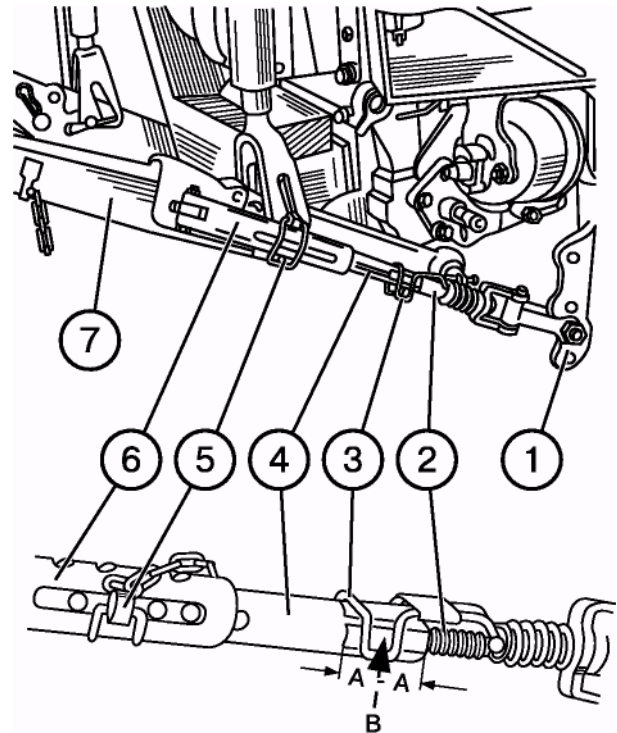

Inner tie bars (2)*

They are also used to limit the lateral swinging of the machines in working and transport states.

NOTE: The telescopic tie bars are installed from the outside only

Partial locking (for tillage)

The adjustments at working position of the machine shall be made as follows:

- screw the adjusting bolts (1) into the holder to the full;
- raise the machine a little so that its driven elements do not touch the ground;
- adjust the length of the right angle brace to the given tilling depth (when operating the plough);
- adjust the length of restricting chains ensuring the machine displacement horizontally to 125 mm in each direction from the mid position or in accordance with the operating manual for the machine by rotating the tie bars (2).

When putting the machine into transport position, screw in the bolts (1) for its partial locking. The machine swinging not exceeding 20 mm in both directions is allowed.

Full locking (for cultivation, sowing, etc.) shall be set as follows:

- screw in fully the adjusting bolts (1);
- shorten the tie bars (2) as much as possible.

IMPORTANT! When changing the length of the right angle brace, do not forget to re-adjust the tie bars.

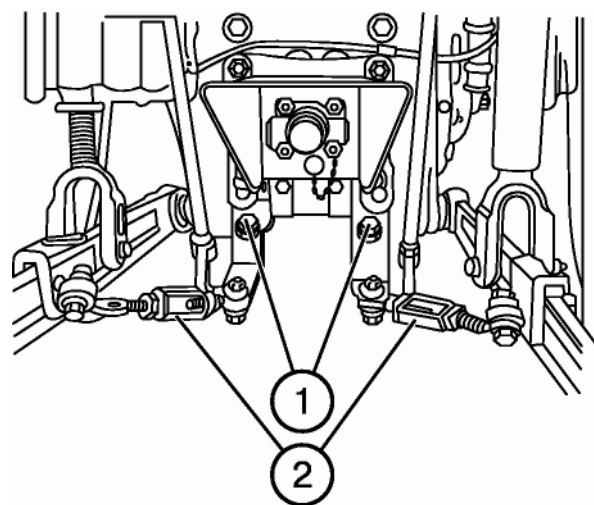

* Not applied for tractors equipped with hydraulic lift.

External chain couplings (2) Partial locking

Ensure the horizontal displacement of the machine under working condition by connecting restricting chains to the bottom apertures of the holder (1) and adjusting the chain length using tie bars (2) to obtain the implement swinging of at least 125 mm in each direction or in accordance with the operating manual for the machine.

When operating the ploughs, adjust the length of the right angle brace to the tilling depth.

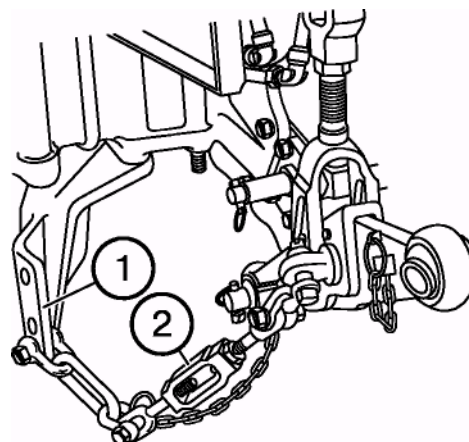

ATTENTION! When lifting the machine to the transport position, keep obligatorily the swinging of the machine to at least 125 mm to prevent the chain from breakdown.

When putting the machine to the transport position, strain the chains by using the tie bars (2). Swinging of not more than 20 mm in each direction is allowed.

Full locking

To lock the machine fully in the working position, attach the restricting chains (2) to the second from bottom aperture of holder (1) and reduce the chain (2) length to the maximum extent.

In the transport position the locking is ensured automatically.

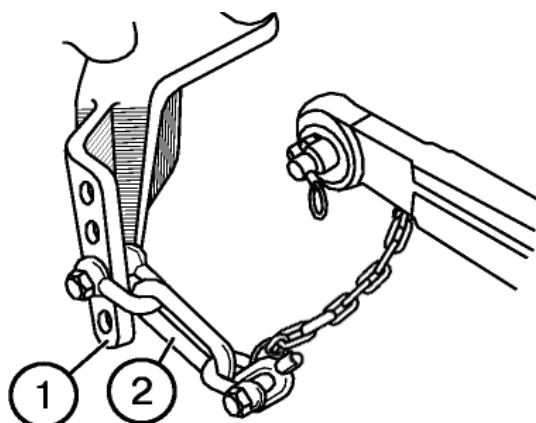

Additional hanger axes of the lower rods of the hinging mechanism

When cultivating high-stem crops, install the lower rods (3) onto the additional hanger axes. When doing this, attach the restricting chains (2) to the third from bottom aperture of the holder (1) for partial locking of the implement and to the fourth one for full locking.

In the transport position the locking is ensured automatically.

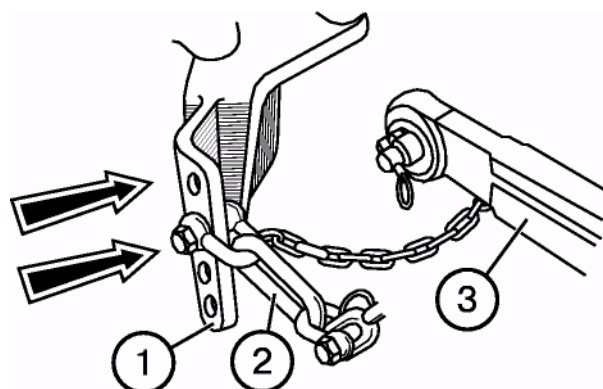

Traction hitch mechanism TCY-1Ж** (cross-bar) (4)

The traction hitch mechanism is used for attaching the machines operating at the speeds of up to 15 km/h. Tractors are shipped from the factory with the cross-bar installed as shown in Fig. 1. To re-adjust from the transport position (I) to the working state (II), proceed as follows:

1. Unsplint and pull out the lug (3) and remove the cross-bar (4).
2. Unsplint and pull out the pin (2) and remove the rear ends of the lower rods (5).
3. Fix cross-bar (4) onto the front ends of lower rods (1), fix it with the lug (3), restricting chains, pins (2) and splint pins (see Fig. II).

In case of external or internal fitting of the restricting chains, ensure the full locking of the traction hitch mechanism. In case of fitting of a traction hitch mechanism with telescopic tie bars, attach them to the second from bottom aperture of the holder and ensure the full locking.

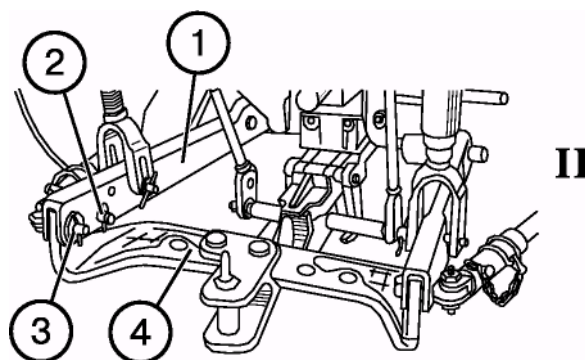
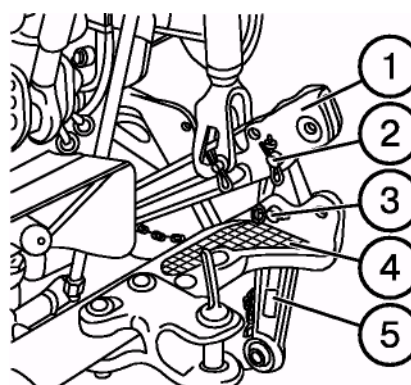

IMPORTANT! Make sure that the traction hitch mechanism is locked against lateral swinging by adjusting the internal or external tie bars.

* Not applied for tractors equipped with a hydraulic lift.

Front weights (1) and (5)

To preserve the normal steerability of the tractor under considerable unloading of the front axle when operating heavy mounted machines and implements, install additional weights (1) (10 pieces of 20 kg each) or weights (5) (10 pieces of 45 kg each). The weights (1) are installed onto a special holder (2) which is fastened to the front beam of the tractor and is tightened with string (4) and nut (3).

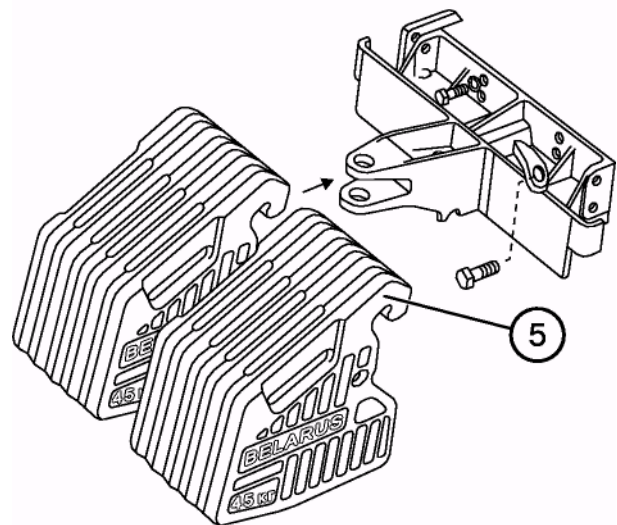
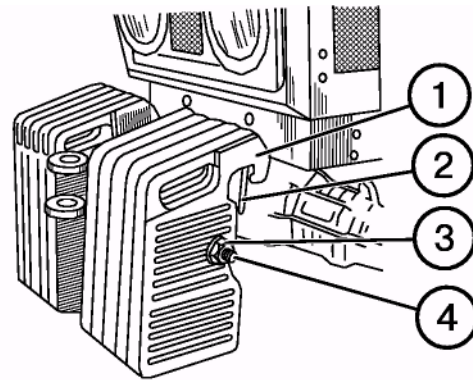

Adjustable limiter of implement lifting (2)*

To limit the travel of drawing of the plunger of the rear cylinder of the hitching mechanism (implement lifting height), use the adjustable rest (2). To do this:

- loosen butterfly nut (4);
- move the adjustable rest (2) along the cylinder plunger (3) to the required position and tighten the butterfly nut (4) by hand. As the implement is lifted to the required height, the rest (2) will shift the stem of the hydromechanical valve (1) and lock the cylinder cavities.

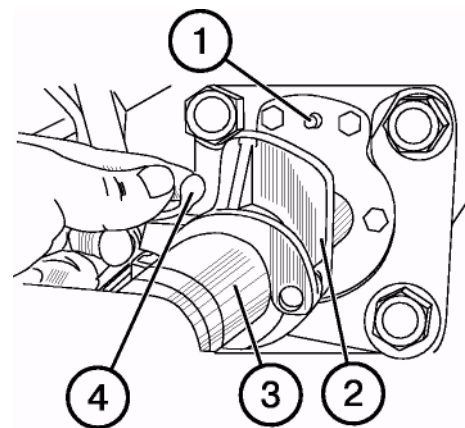

ATTENTION! To prevent the cab damage by the components of the lifted implement, adjust lengths of left and right angle braces in accordance with recommendations.

* Only applied for tractors with independent power cylinder of HMS (with power governor).

Traction hitch mechanism TCY-3K* (trailer gear with automatic hitching)

Attention!

1. Never try to use the trailer gear for working with semi-trailers or single-axle trailers.
2. When towing the trailers, always apply safety chains.
3. Never use rear hinging mechanism when trailer gear is installed on the tractor.

The trailer gear is fastened to the tractor with two pins.

The tractor is shipped from the factory with the trailer gear supported by the upper pin (transport position) only. To set the trailer gear to the working condition, proceed as follows:

- lift slightly the gear and remove pin (1);
- refit the upper rod (2) to the upper opening of the shackle;
- remove the lower pin while holding the gear in the upper position;
- lower the gear, align the holes in the gear, in the holder with those in the shackle and insert the lower pin.

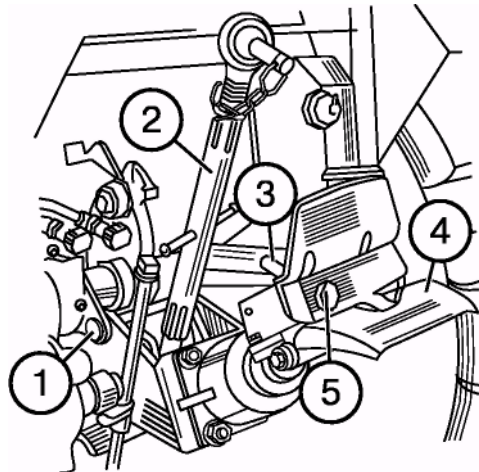

The trailer gear can be installed in two positions:

- lower, for operating the tractor with the trailers not requiring the use of PTO rear shank;
- upper, for operating the tractor with the trailers requiring the drive of active elements from the PTO rear shank (in this case turn the trailer gear by 180°).

When hitching the tractor and the trailer, the gripper (4) serves as a guide for the trailer hitch eye. To attach the trailer, move the tractor back. As a result, the trailer hitch presses and sinks the pin (5) and enters the hook jaw. The hitching takes place automatically. To unhook the trailer, pull the handle (3) and take hitch eye from the hook.

* Not applied for tractor equipped with hydraulic lift.

Mechanism for fixing the hanging in the transport mode*

The fixing mechanism (2) is intended for fixing the mounted attachment in the transport position to prevent the mounted implements from lowering.

Applying this mechanism ensures the mechanical locking of the rotary lever (3) fitted on the rotary shaft (5), and, respectively, lifting levers of the mounted attachment (4) fitted on the same shaft.

To fix the hanging, lift it to the uppermost position and then turn the handle (1) to the left as far as it will go.

To disengage the fixing mechanism, put the handle of the power governor to the "lift" position to release the fixation gear from the load and then turn the handle (1) to the right as far as it will go.

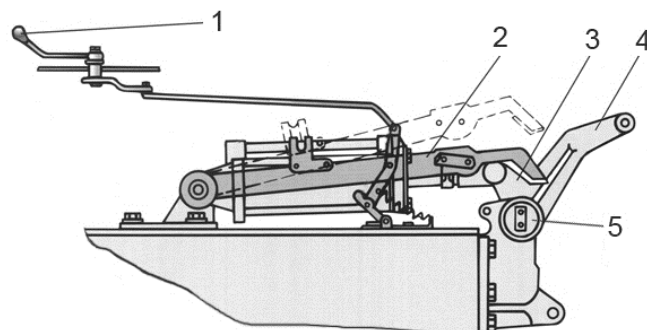

* Only used for tractors with independent power cylinder of HMS (with power governor).

Controlling the hydraulic system and mounted attachment without power governor

On the tractors without power governor, the mounted attachment is controlled by means of the rightmost handle of the distributor.

When operating the mounted machines, use handle positions "lift" and "floating" only.

It is forbidden to put the handle to position "lowering" when operating mounted tillage machines!

Only use the "lowering" position when controlling the external cylinders installed on the machine and designed for adjusting the position of working units (such as a reel, header, opening ploughs, etc.) of harvesting, sowing and other machines. If the distributor handle does not automatically return to the neutral on completion of the cylinder movement, do it manually. And vice versa, in case of earlier return of the handle, hold it by the hand until the operation is completed.

Controlling the hydraulic system and mounted attachments with a power (position) governor

Power control

Using the power control ensures the best improvement of the productivity when performing the power intensive agricultural operations, such as tillage, deep opening and cultivation when operating the tractor with mounted agricultural machines.

When tilling with the ПНЗ-35Б and ПЛН-3-35 ploughs, lift the plough support wheel to the uppermost position.

When ploughing at small depth (less than 20-23 cm) under conditions, where the soil density along the run length varies considerably (sand – clay), lower the support wheel to limit the maximum depth on the plots with low soil density.

When performing the continuous cultivation and deep opening in case of unitization of the tractor with agricultural machines with two support wheels within takeover width measurement plane, put the support wheels to the required height to exclude lateral warps of the agricultural machine, uneven loads on the outermost (right and left) driven elements.

When preparing the unit for operation with power control application, proceed as follows:

1. Install a central rod of the hitch to the upper hole of the shackle (position I).
2. Connect the mounted machine with the tractor hitch.
3. Enable the power control. To do this, lift slightly the mounted machine above the ground and put the switch (1) to the slot of the power arm (2) by turning the switch to the left (down tractor motion). To facilitate the switching on, move the switch forward (in the direction of the tractor motion) to align it with the recess on arm (2) prior to putting to slot.
4. On wide-takeover machines, adjust the support wheels and driven elements to height. When unitizing with the ploughs, lift the support wheel to the top position.

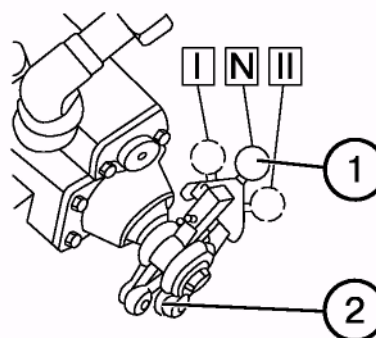
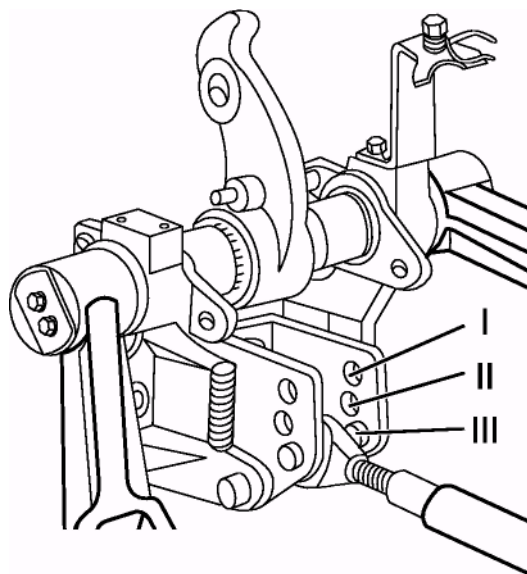

Operation rule and techniques

At the beginning of the run, lower the mounted machine by turning the handle (2) forward. The farther the handle is put, the deeper the soil tillage depth is.

As the arm (2) is pulled towards the operator, the depth is decreased. After adjustment to the required depth, move the limiter (1) along the console slot to the stop against the handle and fix.

To raise the implement at the end of the run, pull the handle (2) to the "lift" position (towards yourself to the stop). As the lifting is completed, the handle shall return spontaneously to the neutral position "N".

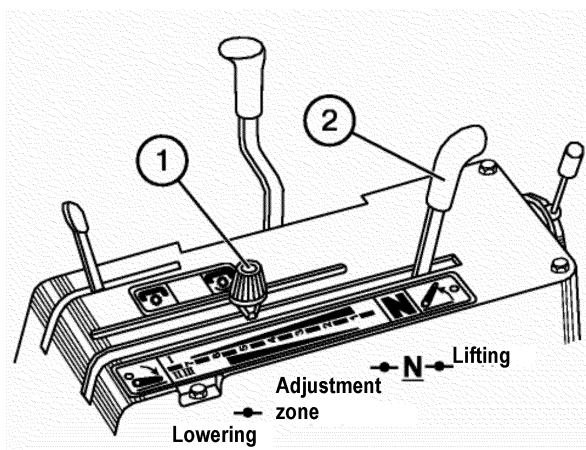

At the beginning of each run, lower the implement by pushing the handle (2) forward to the stop against limiter (1).

Operation of the tractor equipped with a power governor

When the depth obtained during the tillage with the power control handle put to the maximum depth is insufficient, reposition the central rod (1) of the hitch to the middle hole of shackle (2).

When operating using the power control for both tillage and cultivation, adjust the correction rate handwheel (1). Rotating the handwheel clockwise reduces the correction rate and rotating the same counter-clockwise increases the rate.

The handwheel should be adjusted on completion of the plough (cultivator) adjustment; when doing this, achieve the smooth automatic depth control during the operation by rotating the handwheel.

Do not rotate the handwheel clockwise to the stop since it will result in too slow lifting of the agricultural machine and cause higher skidding of the tractor's driving wheels.

Adjust the correction rate handwheel and select the holes in the shackle when installing the central rod for particular soil conditions and each type of agricultural machines. No re-adjustments in the operation are required.

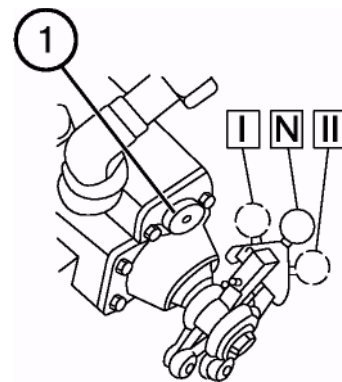
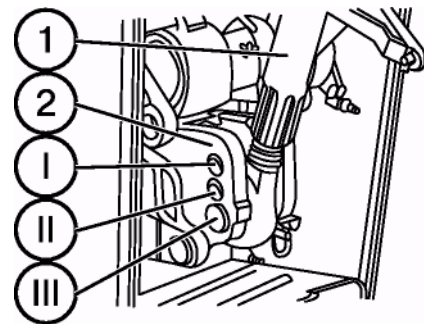

Position control

When applying the position control, the power governor of the hydraulic system ensures the automatic keeping of the specified position of the agricultural machine relatively to the tractor frame.

It is recommended to use the position control during the soil cultivation by using mounted ploughs and cultivators for continuous and multi-row tilling, as well as during the deep opening under the conditions of even field relief.

When operating the wide-cut machines unitized with the tractor in the position control mode, it is necessary to use the support wheels for excluding the lateral warps of the agricultural machine, improving the linearity of the unit motion and creating the better conditions for imitating the relief in the lateral direction (relatively to the tractor motion).

To prepare the implement for operation in the position control mode, proceed as follows:

1. Connect the machine to be mounted with the hitch of the tractor.
2. Lift the mounted machine to upper (transport) position.
3. Switch to the position control mode. To do this, move the switch (3) to the slot of the position lever (1) turning it to the right (in the direction of the tractor motion) to position I.
4. Turn the correction rate handwheel (2) counter-clockwise to the stop, setting the maximum lifting rate for automatic corrections of the position.

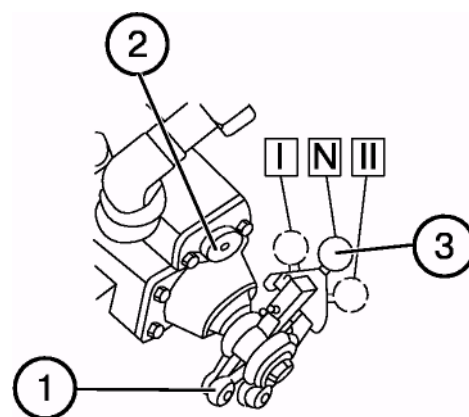

Operation rule and techniques

Set the mounted machine to the required position. To lower it, push the handle (2) forward. The farther the handle is pushed forward, the lower the machine is. Having set the machine to the required height, move limiter (1) to the stop against the handle and fix it.

To lift the machine to transport position at the end of the run, pull the handle (2) towards yourself to the stop. After lifting, the handle shall return spontaneously to neutral position.

Height control

The height control can be used when unitizing the tractor with mounted machines fitted with the support wheels. It is based on the principle that the given tillage depth is ensured by setting a certain height of the support wheel of the agricultural machines unitized with the tractor. When working in the height control mode, set the switch (1) to the middle position (N). To lift the machine, pull the handle (2) towards yourself to the stop and hold it until lifting is completed. When it will be done, the handle shall return spontaneously to the neutral position "N". To lower the machine, push the handle (2) forward to the control zone prior to machine descent.

It is forbidden to set the handle (2) to the "forced lowering" position (forward to the stop) when operating the mounted machines. Only use the forced lowering when attaching the machine to the tractor hitch. For forced lowering, push the handle (2) to foremost position. After releasing the handle, it must return to control zone and hitch lowering must stop.

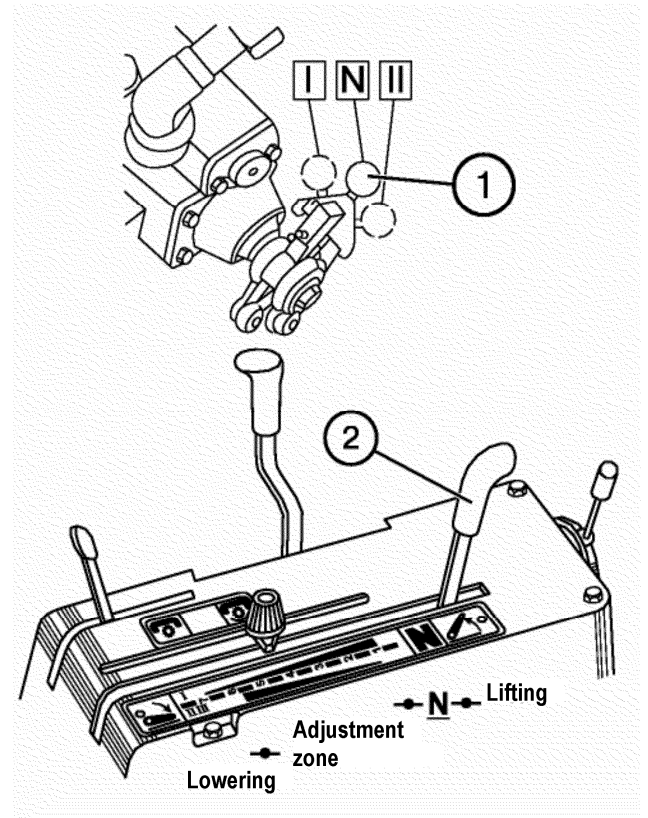
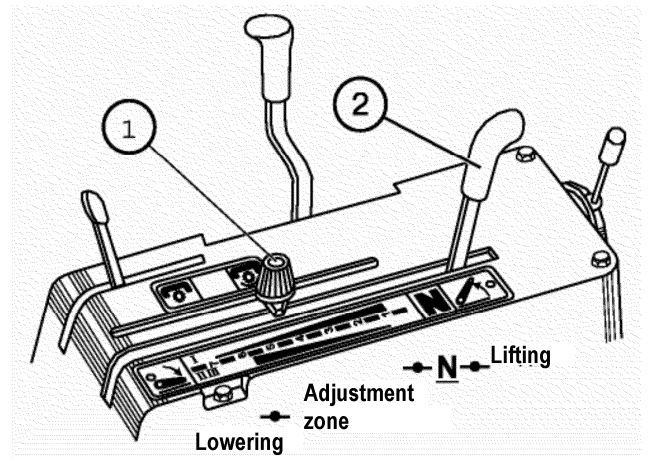

Operation of the tractor equipped with the HMS with a hydraulic lift

Compared to the above-described ADCS system with an autonomous power governor and power cylinder, the HMS with a hydraulic lift is controlled by two levers located in the cab on the right control panel:

- power control handle (1); and
- position control handle (2).

Position control

1. Push the power control handle (1) to the foremost position in the direction of the tractor motion (digit “9” on the board).
2. Set the required height of the machine above the ground using the position control handle (2).

The digit “1” on the board corresponds to transport position of the RMA and digit “9” to the minimum implement height above the ground.

If the maximum lifting height is to be limited (e.g. due to possible failure of the rear PTO parts), set the maximum lifting height by means of the handle (2) and move the adjustable rest (3) towards it.

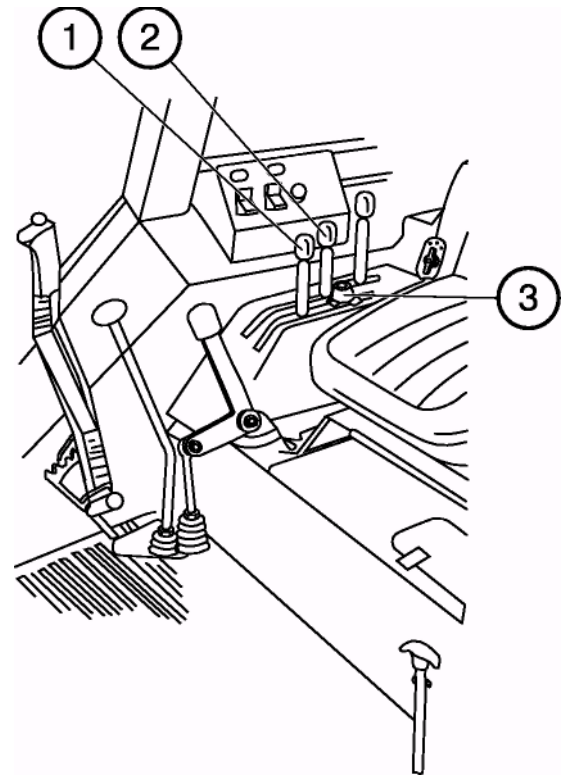

Power control

Use this control mode when operating the mounted machines (ploughs and cultivators). Move the power control handle (1) to foremost position in the direction of the tractor motion (digit "9" on the board).

- Move the lower rod joints to the required position using the position control handle (2) and attach the implement to the rear hitch.
- Having entered the furrow, push the handle (2) to foremost position and adjust the required tillage depth using the handle (1).
- When leaving and leaving subsequently the furrow (when tilling), use the handle (2) only without touching the power control handle (1).

Combined control

If you cannot reach steady soil tilling depth due to non-uniform soil density, limit the maximum depth by the position control handle (2) (combined control mode), having remembered the respective digit on the board.

Peculiarities of operation of the tractor with machines requiring the drive from the rear PTO

- a) prior to attaching the machine to the tractor, make sure of correct adjustment of the rear PTO control;
- b) install and fix reliably the required (8- or 21-spline) PTO shank and engage the drive with the respective rotational speed; here set 540 rpm for 8-spline shank and 1000 rpm for 21-spline one.

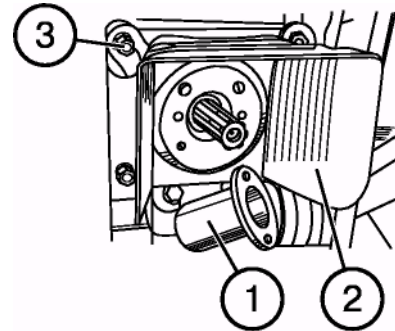

To replace the PTO shank, proceed as follows:

- 1. Unscrew two bolts and remove the cap (1).
- 2. Unscrew four nuts (3) and remove the housing (2).
- 3. Unscrew six bolts (4), remove the plate (6) and take the shank (5) away.
- 4. Install another shank into the spline opening and mount the plate (6).
- 5. Assemble the other parts in the reverse order.

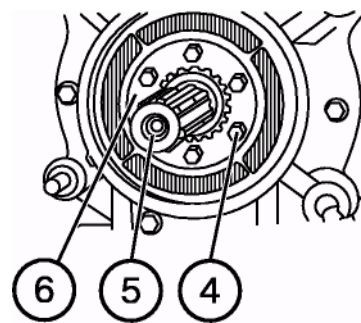

- c) lubricate the shaft and driveline telescopic connection tube with the cup grease. Install driveline joint onto the PTO shank and reliably fasten it in the fixation groove. Make sure that the lugs (2) of the forks (1) of the joint joints (1) of the intermediate (telescopic) shaft lie in the same plane. Non-observance of this requirement causes driveline and PTO overloads;
- d) install agricultural machine cardan shaft housing;

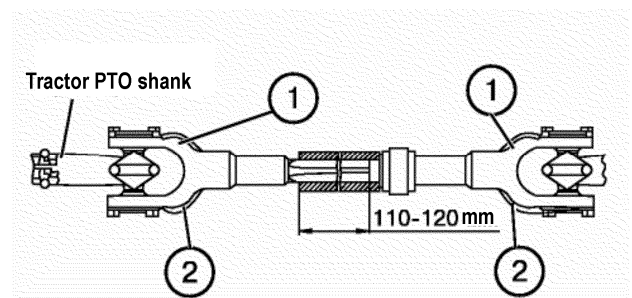

e) having installed the driveline, make sure that the components of the driveline telescopic connection do not abut during extreme machine positions relative to the tractor; the minimum overlap of the driveline telescopic connection shall be 110-120 mm, because lower overlap value could cause the transmission disconnection.

The length of the safety clutch spring (1) of the agricultural machine must be adjusted in such a way that the jaw clutches 2 and 3 would rotate one relatively another during overloads. Excess tightening of the spring causes the failure of the clutch to operate and overloads of the driveline and PTO.

Activate the independent PTO drive when the engine is stopped or running at the minimum speed. The synchronous PTO drive should be activated with the engine running by engaging smoothly the clutch.

When operating the tractor without the PTO, set obligatorily the PTO control lever to the "PTO OFF" position, the two-speed PTO drive clutch – to position 1 (540 rpm) and the lever for toggling between the independent and synchronous PTO drives – to the middle (neutral) position.

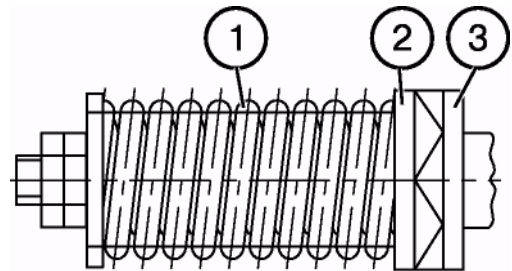

The tractor motion with the synchronous PTO drive engaged is allowed at the speed of not more than 8 km/h;

- f) Disengage the PTO when turning the unit (for trailed machines), as well as when lifting the machine to the transport position (for mounted and semi-mounted machines);
- g) Having unhooked the machine from the tractor do not leave the driveline joint on the PTO shank;
- h) When installing the driving pulley on the rear PTO cover, as well as reducing gear for driving a special machine (cotton-growing, excavating machines, etc.), make sure that they are centred relatively the shank (seated into boring $\varnothing 162$ mm on the rear cover) and their fixing nuts are reliably tightened.

When working with rotary machines for tillage:

- a) Watch the running order and normal operation of safety devices;
- b) Do not engage PTO on when the driven element is on the ground;
- c) Lower the machine with rotating operating parts smoothly during the tractor motion;
- d) Do not engage PTO, if the refraction angle at one of the driveline joints exceeds 35° ;
- e) When operating on hard soils, till lateral strips to enter the field and only after that carry out the tillage in longitudinal direction.

Operating the trailers and trailed machines

The single-axle machines like semi-trailers are hooked up to the tractor by means of the TCY-2 and the trailed ones – via TCY-3K* (trailer gear with automatic hitch). Transporting the machines by using TCY-1Ж (cross-bar) is allowed at the speed of below 15 km/h without entering general-purpose roads and when performing the agricultural works.

ATTENTION!

It is strictly forbidden to unitize the machines like trailers and semi-trailers via TCY-1Ж (cross-bar).

Connect the connecting heads of the trailer pneumatic system with the tractor pneumatic system depressurized.

When working with single-axle trailed machined, install additional weights for loading additionally the front axle of the tractor.

Two-axle trailers are hooked up to the tractor by means of the TCY-3K or TCY-3B (their hitching with the TCY-1Ж fork is not allowed). Having hooked up the tractor with the trailer, make sure that the latch has fully left the body, and connect the trailer to the tractor with the safety chain (cord).

When trailer gear is installed on the tractor, it is forbidden to attach semi-trailers (single-axle trailers) as well as two-axle trailers with non-standard hitch to it.

Via TCY-2B or TCY-3B – for tractors equipped with hydraulic lift.

It is strictly forbidden to use the rear hinging when the trailer gear is installed on the tractor!

The trailers shall be used at the speeds defined by the road conditions. It is allowed to operate the trailers 2ПТС-4-887А with the body capacity of 20 and 45 m³ at the speeds of up to 15 km/h, since their stability is lower. Avoid sharp turns of these trailers and broadcaster 1ПМГ-4 to prevent damage of fenders of their rear wheel.

The trailer eye (2ПТС-4-785А, etc) shall be fixed against slipping to avoid its jamming.

During the operation, the fork TCY-1Ж shall be fastened to the cross-bar of the hitch with two pins. It is forbidden to use the fork fixed with one pin.

Prior to operation, make sure that the pins and the pivot bolt of the hitch fork are reliably splinted. All the trailer signalling units (stop and turn indicator lights, number plate lighting) are to be connected via the plug socket mounted on the tractor.

Trailer brakes with pneumatic or hydraulic actuator are controlled through the tractor pneumatic system.

Using the optional equipment of the tractor

As optional equipment, a rear driving pulley, side PTO, additional weights for loading the front axle, speed reducer, automatic hitching CA-1, spacer plate for installing the twinned rear wheels and other equipment can be mounted on the tractor.

A rear pulley is installed on the rear PTO reducing gear cover and driven by the PTO slotted shank. To prevent the PTO shank deformation, ensure obligatorily the installation of the housing onto four studs with centring the flange in the PTO cover. Use the PTO control lever for engaging and disengaging the pulley.

The side PTO is installed instead of left cover of the gearbox with leading the controls into the cab. It may be used for additional drive of mechanisms and operating elements of the machines of front and side hooking.

The additional weights with the total weight of 220 or 510 kg are mounted onto a special holder, which is fastened to the front beam of the tractor.

To provide the possibility of using the tractor with the machines requiring lower speeds, a speed reducer is installed. The speed reducer additionally decreases tractor speeds at I and II gears during forward and reverse motion (the speed reducer is optional).

To install a speed reducer on the tractor, follow the recommendations stated in the "Technical Description and Operation Manual for the Speed Reducer" enclosed to each speed reducer shipped against the customer's order.

IMPORTANT! Having installed a speed reducer on the tractor, fill in power transmission with oil to the check plug level and add more 10 litres.

Tyres

IMPORTANT!

1. Never exceed air pressure values recommended by the manufacturer for the tyres.
2. Do not perform welding the disk or other repair works with the tyre inflated. To unfit and repair the tyres, contact the workshop staffed with trained personnel.

Tyres used on the 900 series tractors

	900/900.3/950/950.3		920/952		920.2/920.3/952.2/952.3	
	front	rear	front	rear	front	rear
Standard	9.00-20 9.00R20	18.4R34 (mod. Φ-11)	13.6-20	16.9R38	360/70R24	18.4R34
Optional:	7.50-20	18.4R30 or 18.4/78-30 15.5R38 18.4R34 (Φ-11) 16.9R38 9.5-42 11.2R42	11.2-20	15.5R38 18.4R34 18.4R30 or 18.4/78-30 (18.4L-30) 9.5-42 11.2R42	13.6-20 11.2R24	16.9R30 15.5R38 9.5-42 11.2R42

IMPORTANT! For tractors equipped with a FDA (920/920.2/920.3/952/952.2/952.3), the properly selected combination of front and rear tyres should be used. Using proper front and rear tyre combination will ensure maximum performance of the tractor, increase the tyre service life and reduce the wear of the power transmission components. Simultaneous use of worn-out and new tyres, or tyres with different diameters or rolling radii can lead to violation of the requirements concerning the kinematic non-conformance and excessive tyre wear. The table below gives recommended combinations of front and rear tyres.

Allowable combinations of front and rear tyres for the Belarus 920/920.2/920.3, Belarus 952/952.2/952.3 tractors

Rear tyres \ Front tyres	920/952		920.2/920.3/952.2/952.3		
	11.2-20	13,6-20	360/70R24	11.2R24	13,6-20
9.5-42	+	-	+	+	-
11.2R42	+	-	+	+	-
15.5R38	+	-	+	+	-
18.4R34 (Φ-11)	+	-	+	+	-
16.9R38	-	+	-	-	-
18.4R30 or 18.4/78-30 (18.4L-30)	+	-	-	-	-
16.9R30	-	-	-	-	+

To ensure the normal operation of the tractor, set the air pressure in the tyres according to the table given below. The pressure must be set in cold tyres. When carrying out the works requiring traction forces, set the pressure as for the speed of 30 km/h. When performing the transport works on the roads with hard surfaces, increase the pressure by 30 MPa. When operating the front lift, set the maximum pressure specified for the front tyres.

Norm of the tyre loads for selecting the operating mode at different inner pressures

Tyre size	Speed symbol	Tyre load, kg at the inner pressure, MPa and at the speed designated by the symbol										
		0.08	0.1	0.12	0.14	0.16	0.18	0.2	0.22	0.24	0.26	0.28
7.50-20	A6				580	625	670	715	760	800	835	875
9.00R20	A6	580	640	715	780	840	900	960	1020	1070	1120	
11.2-20	A6		765	850	930	1000	1080	1145				
13.6-20	A6	1020	1100	1200	1300	1400						
11.2R24	A8	785	895	995	1090	1180						
360/70R24	A8	1090	1180	1285	1400	1500						
16.9R30	A8	1535	1745	1945	2125	2300						
18,4R30	A6	1750	1975	2200	2425	2650	2800					
18,4/78-30 (18.4L-30)	A8		2005	2225	2430							
18.4R34	A8	2020	2220	2410	2610	2800						
15.5R38	A8	1420	1620	1810	1945	2120						
16.9R38	A8	1700	1920	2140	2355	2575						
9.5-42	A6	710	810	910	990	1065	1145	1220				
11.2R42	A6	895	1020	1140	1240	1335	1435	1525	1620	1700		

For tyres with speed symbol A6, the loads are given for the speed of 30 km/h.

For tyres with speed symbol A8, the loads are given for the speed of 40 km/h.

Allowable load variation on guide and drive wheel tyres, depending on speed

Speed, km/h	Load variation, %, on the guide wheel tyres with the speed symbol	
	A6 (30 km/h)	A8 (40 km/h)
10*	+50	+67
15	+43	+50
20	+35	+39
25	+15	+28
30	0	+11
35	-10	+4
40	-20	0
45	-	-7

* For tyres with ply-rating 6 and more, inner pressure shall be increased by 25%.

When using tyres with ply-rating 6 and more on front lifts, load increase of up to 100 % per tyre is allowed only in loading mode.

Speed, km/h	Load variation, %, on the drive wheel tyres with the speed symbol	
	A6 (30 km/h)	A8 (40 km/h)
10*	+40	+50
15	+30	+34
20	+20	+23
25	+7	+11
30	0	+7
35	-10	+3
40	-20	0
45	-	-4
50	-	-9

* The inner pressure shall be increased by 25%.

Load variation is allowed shortly, for not more than 10 % of the shift time.

Note. Depending on speed, load variation is applied in cases, when the tyre is not subjected to long-term operation under high torques. When performing the field works and under other conditions of long-term operation at high torques, the values corresponding to 30 km/h speed shall be applied.

When performing the transport works on hard surface roads, increase the pressure by 30 MPa (0.3 kgf/cm²)

In case of twinning the wheels, their total capacity shall not exceed that of a single tyre more than 1.7 times.

In case of twinning the wheels, set the air pressure in the tyres of the outer wheels to be 1.2...1.5 times lower than in those of the inner wheels.

Allowable loads on front and rear axles

Tractor model:	Allowable load, kN (without tyre carrying capacity)	
	On the front axle	On the rear axle
BELARUS		
900/900.2/900.3/950/950.2/950.3	17.5	50.0
920/920.2/920.3/952/952.2/952.3	24.0/30.0*	50.0

Note:

1. The loads on the axles shall not exceed the total carrying capacity of the single tyres of the front and rear wheels.
2. When setting the track above 1800 mm, the loads on axles shall be reduced on the basis of 5% per each 100 mm of increase of the track.

Set the air pressure in the tyres in accordance with the tables above.

Liquid ballast

Filling the tyres with liquid ballast is only used in case of insufficient grip of the wheel with the soil under unfavourable conditions (overwatered soil, etc.).

NOTE: It is not recommended to fill the front tyres with ballast, since it impairs the tractor steerability.

In cold season it is recommended to use the mixture of calcium chloride with water on the basis of:

Ambient temperature, °C	Amount of calcium chloride, g/l of water
up to -15°C	200
up to -25°C	300
up to -35°C	435

This ensures the low freezing point and higher density of the solution and provides safe and economical ballast. If used properly, it does not cause any damages to tyres, tubes or rims.

When filling the tyre with water solution of calcium chloride, the tyre valve shall be at the highest point of the wheel.

The table below gives the amounts of solution to be poured into the rear tyres:

Tyre size	Amount of solution filled, l/tyre
16.9R38	280
15.5R38	206
18.4R30 or 18.4/78-30 (18.4L-30);	320
18.4R34	360
16.9R30	250

IMPORTANT! The tyres may be filled to 75% of their volume. In case of excessive filling, air volume will be insufficient for impact absorption, which can result in tyre damage.

WARNING: when mixing the solution, calcium chloride flakes have to be added into water and stirred to reach complete dilution of CaCl₂. **Never add water into calcium chloride.** When preparing the solution, put on safety goggles. If the solution gets into eyes, cleanse then with clean water within 5 min. Apply for medical assistance as soon as possible.

Installing twinned rear wheels

To increase cross-country ability, twinned rear wheels with the standard size of 9.5-42 and 15.5R38 can be installed on the tractor with the use of additional spacer plates. To mount an additional wheel, remove the main one, press out short bolts (2) from the hub (1) and press in the long bolts included into the spacer plate set. Place the main wheel on the bolts (2) and fix it with the nuts (3). Then install the spacer plate (4) on the same bolts (2) and fix it with nuts (5). Then mount the additional wheel on the spacer plate bolts (6) and fix it with nuts (7). The nut tightening torque for fastening the rear wheels is 300...350 N•m (30...35 kgf•m).

ATTENTION! It is forbidden to use twinned wheels to increase traction force on the hook.

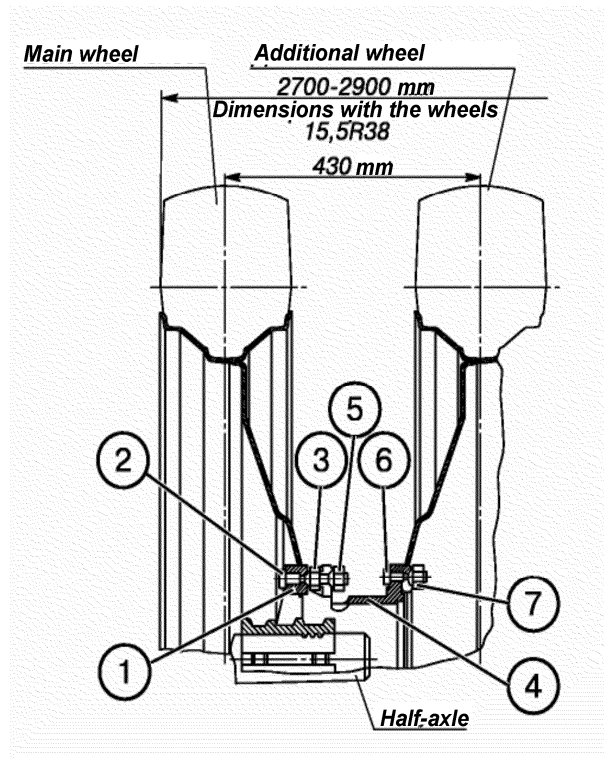

Pneumatic system of trailer brake control

Single-line pneumatic actuator

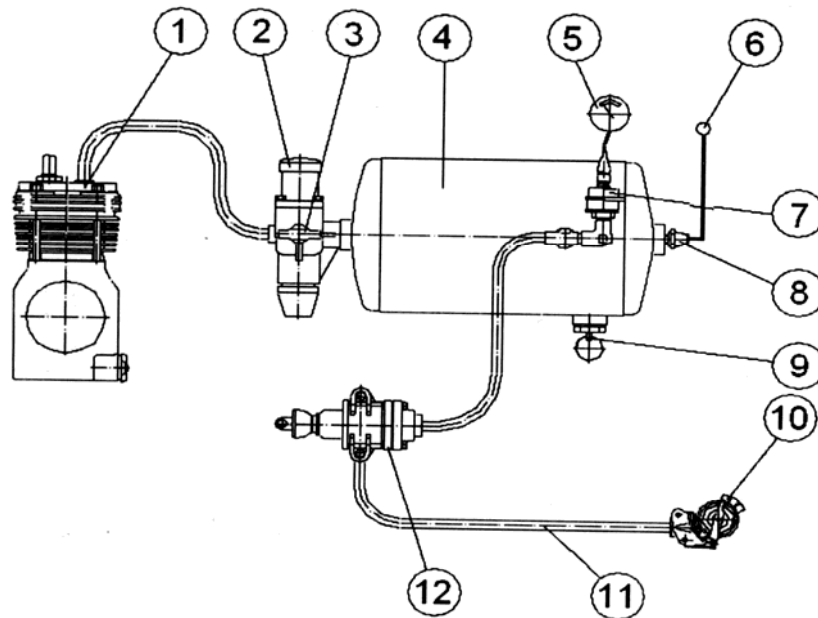

1 – compressor; 2 – pressure regulator; 3 – air intake valve; 4 – tank; 5 – pressure indicator; 6 – emergency pressure pilot lamp; 7 – pressure transducer; 8 – emergency pressure sensor; 9 – condensate removal valve; 10 – connecting head; 11 – control line; 12 – brake valve.

The tractor is equipped with the pneumatic system controlling the brakes of the trailers and other agricultural machines equipped with pneumatic brake actuator.

The pneumatic system is also used for inflating the tyres and other purposes, when compressed air power is required.

The pneumatic system is also used for inflating the tyres and other purposes, when compressed air power is required.

Air is taken to the system from the engine intake manifold. Air is compressed in the compressor (1) and supplied to tank (4) via pressure regulator (2) maintaining the required pressure in the tank. Compressed air is supplied from the tank via pipeline to the brake valve (12). From the brake valve air is passed via control line (11) to the connecting head (10) and then to the pneumatic system of the trailer. The air intake valve (3),

which used for inflating the tyres and other purposes, is installed in the pressure regulator. To monitor air pressure in the system, there is a pressure transducer (7) and the emergency pressure drop sensor (8) and on the dashboard – pressure indicator (5) and red pilot lamp (6). To remove condensate from the tank, the valve (9) is provided.

The brakes of the trailers and agricultural machines are controlled in two modes: direct and automatic.

The direct control of the brakes is exercised at the cost of the pressure drop in the connecting line when braking the tractor to zero.

The automatic brake control is exercised by at the cost of the pressure drop to zero in the trailer connecting line in case of its disconnection (detachment) from the tractor. Here the valve in the connecting head of the tractor is automatically shut

off that prevents compressed air outflow from the tractor system.

Two-line pneumatic drive (Belarus-900.3/920.3/950.3/952.3)*

The tractors may be equipped with two-line pneumatic brake actuator for the trailers equipped with pneumatic brake actuator.

Pneumatic drive is also used for inflating the tyres and other purposes, when the compressed air power is required.

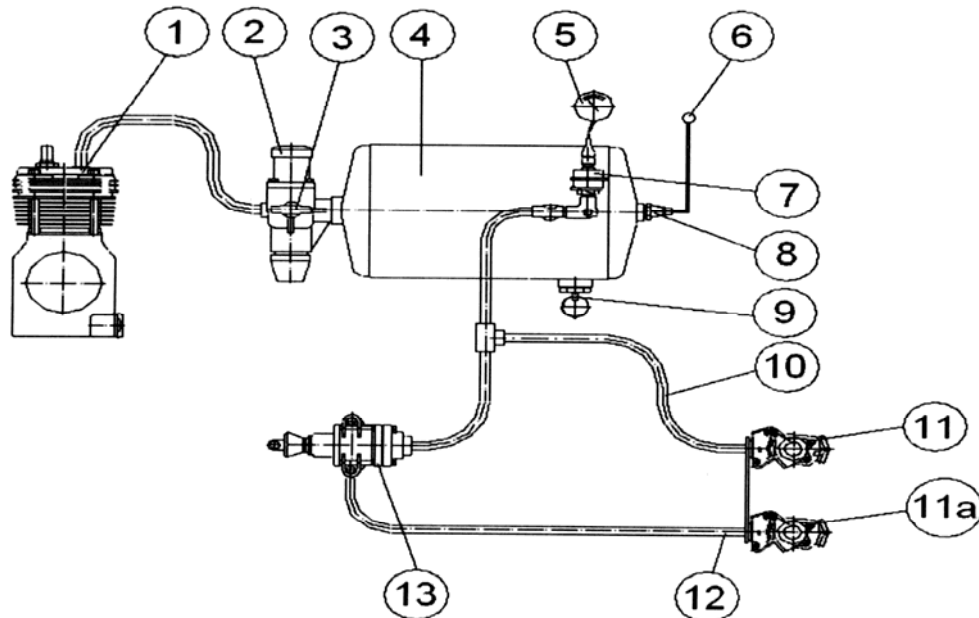

1 – compressor; 2 – pressure regulator; 3 – air intake valve; 4 – tank; 5 – pressure indicator; 6 – emergency pressure pilot lamp; 7 – pressure transducer; 8 – emergency pressure drop sensor; 9 – condensate removal valve; 10 – supply line; 11, 11a – connecting heads; 12 – control line; 13 – brake valve.

Air is taken into the system from the engine intake manifold. Air is compressed in compressor (1) and supplied to tank (4) via pressure regulator (2) maintaining the required pressure in the tank. Compressed air is supplied from the tank via pipeline to the brake valve (12). From the brake valve air is passed via supply line (10) with the connecting head (11) (with red cover), which is constantly under pressure.

The brake valve with connecting head (11a) (yellow cover), where there is no pressure. Controlling the brakes of the trailers and agricultural machines is exercised in two modes: direct and automatic.

The direct control is exercised by the pressure build-up in the control line (12) to 6.5-8.0 kgf/cm² when braking the tractor.

In this case, the supply line (10) remains pressurized and compressed air feeding to the trailer pneumatic system goes on.

Automatic brake control is exercised at the cost of pressure drop to zero in the trailer supply line during in case of its disconnection (detachment) from the tractor. Here the valve in the connecting head (red cover) is automatically shut down preventing compressed air outflow from the tractor system.

* For other models – optional.

AGGREGATION

The section “**TRACTOR AGGREGATION**” contains the necessary information on the peculiarities of the intended use of the BELARUS tractor of your model including the recommendations on the aggregation, selection of machines, conditions of safe use of the tractor and determining the steerability criterion, rules of correct completing of machine-tractor aggregates (hereinafter referred to as the MTA or tractor-based aggregate) as well as some other necessary documentation, making it possible to assess the possibility of using the tractor with machines within MTA's.

The recommendations for aggregation of the specific technical means differing at to their nomenclature and performance characteristics, including description of their design, information on their adjustment, procedure of completing the MTA and technique of performance of the works are provided in the operating documentation for agricultural machines.

1. Intended use of the tractor

- Purpose and specialization:

Wheeled universal agricultural-purpose tilling tractor providing the operation of machines as a power source.

- Kinds of the main agricultural works to be performed:

Cultivation and harvesting of row crops, sowing of cereal crops, harvesting of straw and grasses, transportation works, fertilizing and spraying of fields and gardens, overall tillage, harrowing and ploughing.

- Method of use:

Aggregation of machines with the help of three-point mounted attachments and hitching mechanisms within the MTA.

- Conditions of aggregation of machines:

The tractor provides for the possibility of operation of the machines, the performance characteristics of which are compatible in the part of the aggregation capability with the overall dimensions and allowable vertical static loads on the traction hitch mechanisms and running gear of the tractor as to connecting dimensions, possibility of motion at the necessary speed, power intake and realization of a tractive force under specific operation conditions, overall dimensions and allowable vertical static loads on the traction hitch mechanisms.

- Operation constraint:

The possibilities of use of the tractor under specific conditions are determined by the allowable range of the rated tractive forces at the hook and power of the engine and limited by the maximum allowable loads on the tractor, hitching capabilities of the running gear and allowable skidding, working motion speed, allowable power intake and mass of the machines to be aggregated.

- Operation guidelines:

The tractor shall be operated and the safety requirements when aggregating and servicing the same shall be met in full compliance with the Operating Manual for the tractor, normative documents for labour protection and road regulations. The manufacturer only guarantees the possibility of reliable and safe operation of the tractor provided the customer observes the rules and conditions of the operation, maintenance, transportation and storage specified in this Manual, as well as intactness of the seals. Subject to observance of all the guidelines of the tractor manufacturer, including the speed mode, it is allowed to use the

tractor for performing non-agricultural kinds of works as a power source by aggregating the machines in the MTA using standard working equipment intended for aggregating.

- Qualification of the servicing personnel:

The operation of the tractor by driving and aggregating the same shall be allowed to the persons (hereinafter referred to as tractor drivers, operators) having passed special training and instruction on the matters of the labour protection, having the documents in the form provided by the legislation for the right of driving a tractor and having obtained the permit for operation of a specific tractor.

The owners as well as officials and other persons responsible for the technical condition and operation of the tractor are barred from allowing the tractor to participate in the road traffic and be operated with violation of the requirements of the road regulation and this Manual for the tractor. The owner of the tractor (or person responsible for its operation) shall read carefully this Manual and fulfil all the safety requirements and operation rules stated therein.

Should the owner of the tractor (or person responsible for its operation) does not work on the tractor him/herself, he/she shall make sure obligatorily that all the persons pertaining to the tractor have got the instructions for safety precautions and correct aggregation of the tractor with machines as well as read carefully the Operating Manual for the tractor and understood comprehensively the same.

The tractor driver working on the tractor bears the personal responsibility for observance of the road regulations and safety precautions as well as for correctness of using the tractor in accordance with the Operating Manual for the tractor. Prior to performing the works, the tractor driver shall read also the technical documentation for the machine to be operated with the tractor.

2. Types and classification of agricultural machine-tractor aggregates based on the BELARUS tractors

The agricultural aggregates operated on the basis of the BELARUS tractors are classified according to the following operational signs:

- ✓ **Kind of the process to be carried-out:** ploughing, sowing, planting, soil-cultivating, harvesting and others.

- ✓ **Method of performing the works:** mobile (performing the work in the process of motion; stationary-mobile (performing the work in the stationary or moving state); stationary (performing the work under stationary conditions, when the tractor does not move).

- ✓ **Type of driving the tools of the machine:** tractional, tractional-and-driven and driven. The tractor-based tractional aggregates utilize the whole useful power through a traction hitch mechanism or mounted attachment.

- ✓ The useful power of the tractional-and-driven MTA is utilized simultaneously by traction via traction hitch mechanism of the tractor and through mechanical and/or hydraulic power intake via PTO shaft and free hydraulic outlets of the tractor. The driven MTA's perform the work under stationary conditions (the tractor does not move) through mechanical and/or hydraulic power intake via PTO shaft and free hydraulic outlets of the tractor. A transport MTA is a particular example of the tractional aggregate.

✓ **The number of machines within the MTA:** single- and multi-machine aggregates. A machine performing several working functions, the process modules of which are not intended for using as separate technical mean, is considered to be a single machine.

✓ **Arrangement of the tools relatively to the longitudinal plane of the tractor:** symmetrical and asymmetrical.

✓ **Arrangement relatively to the rear wheels and longitudinal plane of the tractor:** rear, left- and right-side (in the interaxle clearance between the front and rear wheels), front and combined.

✓ **Quantity of the jobs to be performed:** similar tractor-based aggregates performing a single job; combined or complex ones performing two and more jobs simultaneously by means of several machines; combined ones performing several jobs by means of a single machine; universal ones equipped with replaceable tools capable of performing different operations in different time.

According to the method of aggregating with the tractor, the agricultural machines are divided into the following types:

1. **MOUNTED**: to be fastened to the joints of the upper and lower rods of the traction hitch mechanism at three points. The weight of the machine in the transport position is perceived completely by the tractor. The constructional elements of the machine in the transport position have no contact with the bearing area. When re-arranging the machine from the working position to the transport one, the point of connecting the machine with the tractor is moved forcedly to a new height.

2. **SEMI-MOUNTED**: to be fastened at three points to the joints of the upper and lower rods of the traction hitch mechanism, but at only two points – to the joints of the lower rods of the traction hitch mechanism. The weight of the machine in the transport position is perceived partially by the tractor and, to a greater extent, by its own transport wheels (usually one or two). When re-arranging the machine from the working position to the transport one, the point of connecting the machine with the tractor is moved forcedly to a new height.

The two-point articulated joint is implemented by fastening the link pins of the machine mounting axle with the joints of the lower rods of the traction hitch mechanism (the upper rod is not used). The option of use of a cross-bar from the equipment of the tractor or machine is also possible.

3. **SEMI-TRAILED**: to be fastened commonly to the hitching mechanism at one point by means of a hitching loop. The option of the two-point articulated joint with the mounted attachment (without using the upper rod) is also possible. The weight of the machine in the transport position is perceived partially by the tractor and, to a greater extent, by its own transport wheels (usually at least two). When re-arranging the machine from the working position to the transport one, the point of connecting the machine with the tractor is not repositioned.

The semi-trailed machines include also various general- and special-purpose transport facilities, such as general-purpose semitrailers, tank semitrailers, dump semitrailers and special semi-trailed transport facilities for mechanization of jobs in the agriculture. Transportation facilities aggregated by means of saddle-type coupling arrangement are particular examples of semi-trailed machines.

4. **TRAILED:** to be coupled usually by means of a hitching loop to the hitching mechanism. The option of the two-point articulated joint with the mounted attachment (without using the upper rod) is also possible. The weight of the machine in the transport position is perceived completely by the machine's running gear, only the load from the weight of the machine's coupling arrangement is born by the traction hitch mechanism (or mounted attachment) of the tractor. When re-arranging the machine from the working position to the transport one, the point of connecting the machine with the tractor is not repositioned.

The trailed machines include also various general- and special-purpose transport facilities, such as general-purpose trailers, tank trailers, dump trailers and special semi-trailed transport facilities for mechanization of jobs in the agriculture. Transportation facilities aggregated by means of saddle-type coupling arrangement are particular examples of semi-trailed machines.

When aggregating the mounted, trailed, semi-mounted and semi-trailed machines, it is allowed to fasten their individual components (automatic control system boards, markers, limit rods, connecting accessories, brackets, etc.) subject to observation of all the guidelines of the Operating Manual.

5. **ATTACHED:** to be fastened by fixing the assembly units (usually connecting frame) from the complete set of the machine to the mounting holes of the tractor. The joints of the mounted attachment roads fixed at the top position against spontaneous lowering can serve as connecting accessories; in this case, the required position of the machine relatively to the bearing area may be achieved by extending the braces or attaching the special braces from the complete set of the machine. The weight of the attached technical facility is perceived completely by the tractor.

The equipment of this type includes the attached front and grab loaders. It is allowed to use the holes of the semiframe and rear-axle tube for fastening the auxiliary components (tension buckles, brackets, markers and hitches) included in the agricultural machines aggregated by means of three-point mounted attachments and traction hitch mechanisms of the tractor without special permit.

Attention!

1. Aggregation of the attached machines (loaders, bulldozers) is not related to the intended use of the BELARUS tractor.
2. No permit for joint operation of the BELARUS tractors with the mounted, trailed, semi-mounted and semi-trailed machines is required provided such operation comply fully with this Operating Manual for the tractor and does not fall outside the allowable framework of its use. In this case the Minsk Tractor Works shall not bear any responsibility for the failures, breakages and other troubles in the operation of the tractor arisen due to incorrect selection and/or improper use of the machines with the tractor. The agreement of the aggregation of the mounted, trailed, semi-mounted and semi-trailed agricultural machines is a recommended procedure.

3. Recommendations for selecting the agricultural machines for aggregating

The consumer shall select and purchase the agricultural machines to the tractor on his/her/its own based on his/her/its needs and with the account of the characteristics of the machine and tractor as well as local conditions (requirements of the agricultural technologies, soil conditions, personal experience, recommendations of the respective regional advisory centres and organizations for the agricultural production). It shall be kept in mind that the agricultural machines of the same purposes, but from different manufacturers can differ

in the aggregation peculiarities and have different performance characteristics and adjustments.

Usually, the operational documentation for the machines manufactured by reputable manufacturers considers the matters of correct intended use of the machines including the recommendations for selecting and aggregating the tractor as well as safety procedure in sufficient details. In any case, the manufacturer (seller) of the machine shall provide you on your request with the information on the basic minimum characteristics of the tractor which shall ensure the possibility of aggregation of the machine.

The formation of a tractor-based aggregate consists in determining the number and characteristics of the machines to be coupled with your tractor, the hitch (if necessary) and additional equipment to be used, adjustments and settings to be performed and the gear to be engaged. However, it is necessary first of all to purchase the machines. The procedure of formation of the tractor-based aggregates and peculiarities of the work are given in the operation manuals for the technical means to be aggregated. In every case, it is necessary to check the compatibility as to coupling members, load-carrying capacity of the mounted implements and tyres as well as allowable load on the traction hitch mechanism and axles of the tractor.

The BELARUS tractor can be aggregated with the machines having the rated resistance of the tools of 1.4 kN.

The grasp width of the aggregate and operating depth depend mainly on the specific resistance of the soils, which determine the range of operating speeds with the account of agricultural requirements. The heavier is the soil, the higher is the specific resistance.

Based on the tractive force range of 12.8...18 kN provided by the BELARUS tractor on the stubble field, the approximate calculation of the grasp width of the commonly used power-intensive agricultural machines with these tractors (see Table 1). The specific resistance is given for the operating speed of 5 km/h. Variation of the speed by 1 km/h varies the specific resistance by the value of up to 1%.

The interrow cultivation of row crops is provided using the narrow tyres from additional equipment in the row-spacing of 450 to 900 mm. However, the interrow cultivation of maize, cotton and similar cultures using the tyres from the standard equipment is also possible.

Based on its tractive capacity, the tractor can be aggregated with a 4...6-row complex of machines for cultivation of potato in stitches, a 12-row complex for cultivation of sugar beet, 8...12-row complex for cultivation of maize, sunflower, soya and other similar crops.

Table 1

Technical mean	Specific resistance, kN (kgf)	Approximate grasp width, m
Ploughs		
soils: heavy	18...25 (1800...2500)	0.7
medium	12...14 (1200...1400)	1.0
light	6...8 (600...800)	up to 1.7
Disk harrows	1.6...2.1 (160...210)	up to 6.0
Hoeing ploughs		
share scufflers	6.0...10.0 (600...1000)	up to 1.4...2.0
Cultivators	1.6...3.0 (160...300)	4...8
Sowing machines	1.2...1.8 (120...180)	up to 7.2
Harvesters	1.2...1.5 (120...150)	up to 9
Combine harvesters:		
ensilage harvester	2.6...3.3 (260...330)	1.4
potato harvester	10...12 (1000...1200)	1.4

Attention!

It is very important that the manufacturer (seller) of the machine would provide the information on the characteristics of the tractor, which would ensure the possibility of operation of the machine in sufficient details. If such information is unavailable, we recommend to refrain from purchase (operate) such a machine to avoid possibly heavier troubles in the process of its aggregation, which could cause the breakdowns of the tractor

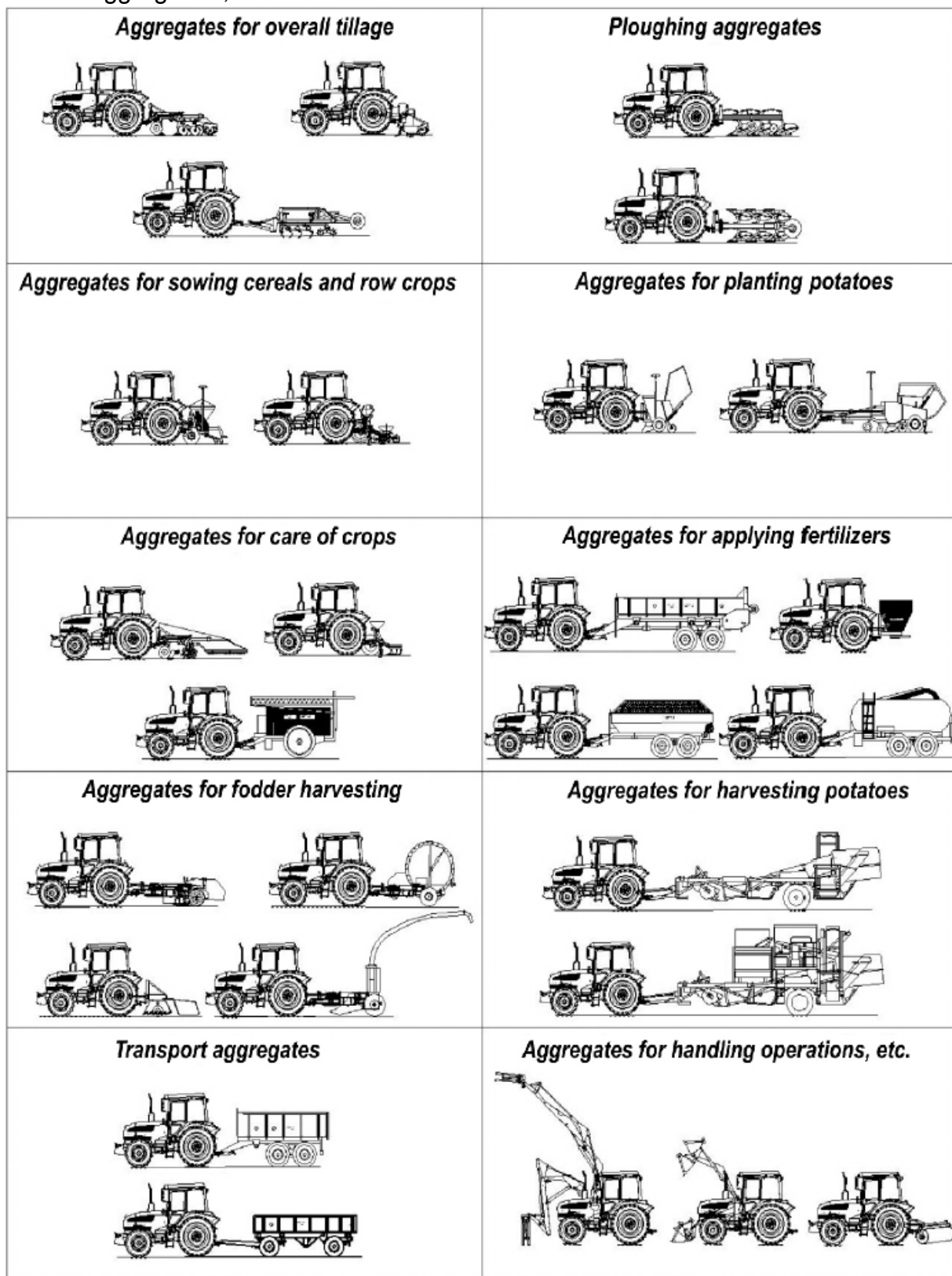

Fig. 1. Main kinds of the machine-tractor aggregates based on the BELARUS tractor

The possibility of aggregation and selection of the machines for the tractor can be determined independently by experimental or calculating method or on the basis of tests performed previously by the respective organizations, for example, zonal machine-testing stations, as well as recommendations of the machine manufacturer.

Calculation method of aggregation. When using the calculation method, the calculations are performed according to the appropriate formulae on the basis of the initial data and technical reference literature, the respective characteristics of selection of the tractor and machine are compared and on the basis of this comparison the conclusion on the possibility of their aggregation is made. This method can be recommended for approximate calculations in cases where experimental data are unavailable or where it is necessary to know immediately the approximate composition of the machine-tractor aggregate. Since the calculations use the medium values and all the peculiarities of the aggregation may not be taken into account, the tractor-based aggregate formed in such a way can be inoperable in some cases and its additional adjustment in the process of field work can be required. This method can be recommended for approximate calculations in cases where experimental data are unavailable or where it is necessary to know immediately the approximate composition of the machine-tractor aggregate.

When using reliable data and taking into account all the power inputs and local conditions, the possibility of aggregation of the machine with the tractor can be checked sufficiently accurately. Such operational calculations are recommended prior to purchasing a new machine.

Experimental method of aggregation. When using the experimental method, the machines are selected and aggregates are further completed by performing the practical check on the basis of the available operational documentation, normative and reference data as well as with the account of the gained experience of forming the aggregates at the specific farm or enterprise.

The initial data for selecting the machines to be aggregated with the tractors include the kind and characteristic of the soil to be ploughed or crops to be cultivated, dimensions and relief of the fields, agrotechnical requirements for the work to be performed (operating speed, agrotechnical clearance, track, tyre width, working travel direction, operation weight, aggregation method, vertical load on the coupling arrangement), draught resistance and power requirements of the working machines, haulage capacity and power of the tractor.

When selecting the machines, pay special attention to the variable characteristics of the conditions of operation of the agricultural machinery under field conditions. For example, the tractor with the drawbar category of 1.4 shall work with the three-furrow plough with the grasp width of 1.5 m under usual conditions, but on the areas with light soils and without slopes it ensures the operation of the four-furrow plough with the grasp width of 1.6 m.

When forming the machine-tractor aggregate, it is extremely significant to select correctly the gear, on which the tractor shall work. Of course, it would be more beneficial to work at high speed and with large grasp width and operating depth of the tools of the aggregated machines. Unfortunately, it is impossible to increase the speed of motion of the aggregate and its grasp width and operating depth. The higher is the speed, the lesser is the tractor's tractive force, therefore, it is necessary to reduce the grasp width and operating depth and vice versa. It is necessary to keep also in mind that the speed and operating depth are often limited by the agrotechnical requirements.

The determination and assessment of the possibility of aggregation of the BELARUS tractor with agricultural machines shall be performed in several stages.

Stage I

Data preparation and acquisition

a. Read carefully the Operating Manual for the tractor. Determine the main technical characteristics of the tractor: drawbar category, rated tractive force, engine power, allowable mechanical and hydraulic takeoff power, coupling dimensions/type (of the traction hitch mechanism or mounted attachment; PTO shanks, hydraulic outlets, electric socket and pneumatic head), positional relationship of the PTO shank end face relatively to the centre of the axis of the mounted attachment hanger or link pin of the traction hitch mechanism; standard equipment, speed and track range, availability of the necessary working equipment and maximum allowable weight of the tractor, allowable loads on the axles and wheel tyres and total weight of the trailer towed.

b. Read carefully the Operating Manual for the machine. Determine the main technical characteristics of the machine: draught resistance, mechanical (power intake shaft), electric and hydraulic power takeoff, coupling dimensions/type (of the hitch bar or tongue loop; coupling triangle; power intake shaft shanks, hydraulic outlets, electric plug and pneumatic heads), positional relationship of the power intake shaft shank end face relatively to the centre of the axis of the coupling triangle or hitch bar or tongue loop; possibility of modification of the standard equipment, power intake shaft type and rotation direction, operating speed range, full service weight with the adjustment rotor, presence of the brakes and cardan shaft (type, length, presence and type of the protective clutch). If necessary, consult with the seller (manufacturer) of the machine and request the missing data about the machine.

Stage II

Checking the assemblability

Assessment of the construction compatibility of the mating members of the tractor (traction hitch mechanisms, three point mounted attachments; hydraulic and electrical connections; pneumatic heads; PTO shanks) with the respective members of the machine including the compliance of the track and standard size of the wheels with the requirements of the technique of the works performed, location of the PTO, power intake shaft and cardan shaft of the machine as well as possibility of the installation of the system for automated monitoring of the process and installation of the monitoring board from the complete set of the machine in the cab.

Check the availability of the necessary equipment for aggregation in the standard equipment of the tractor: required type of traction hitch mechanism, pneumatic head, electric socket, required type of the PTO shank, wheel tyres of the required standard size for twinning, front or rear mounted attachment, reverse control station, spacers for twinning the wheels, availability of the hitching hoses and quick-connection cut-off clutches. The missing equipment of the tractor shall be acquired additionally. After checking the availability of the necessary working equipment and installation of the necessary additional equipment of the tractor, perform the completing and preparation of the MTA with the account of the recommendations of the operating documentation for the technical means to be aggregated.

When purchasing the new machines to be used together with the tractor, it is necessary to specify the presence of the necessary working equipment providing for the possibility of aggregating with the BELARUS tractor of your model.

For the machines located behind the tractor and driven from the PTO, it is necessary to order the cardan shaft of the necessary length and type, with the respective coupling dimensions. The machines driven from the PTO can be equipped with a reduction gear providing for rotation of the cardan shaft both clockwise and counter-clockwise. When purchasing the machine, it is necessary therefore to specify whether it is required to equip the machine with a reduction gear to be driven through the cardan shaft with the direction of rotation of the power intake shaft counter-clockwise, if looked from the side of drive of the machine towards the end face of the cardan shaft yoke.

Stage III

Checking the correspondence of the vertical static load on the traction hitch mechanism or carrying capacity of the mounted attachment to the load created by the machine with the account of the weight of the adjusting load.

Make sure in the possibility of lifting and lowering of the attached machine with the total operating weight by the mounted attachment. Keep in mind that the load created by the machine shall not exceed the recommended values of the carrying capacity of the mounted attachment and allowable vertical load on the traction hitch mechanism.

Stage IV

Checking the vertical static loads on the axles of the tractor including the steerability criteria and necessity of additional ballasting.

Determine the total weight of the tractor with the machine, load on the axles and maximum allowable load on the tyres, weight of the necessary ballast and adjusting load by the calculation or experimental method. The weight of the tractor within the MTA distributed between the tractor's axles shall not exceed the permitted values. In any case, the load on the front and rear axles shall not exceed the total load-carrying capacity of the tyres according to the total load-carrying capacity of the rear or front wheels.

Stage V

Checking the possibility of motion of the tractor aggregated with the machine including checking the turn angles and maximum height of lifting of the mounted attachment until it rests against the tractor members, sufficiency of the length and free space of the cardan shaft when performing turns and transferring the machine to the transport position.

Stage VI

Assessment of the correspondence of the power capabilities of the tractor and power required by the machine (draught resistance and power consumption including that through the PTO). The assessment may be performed by the calculation tee given the initial data or based on the test report.

Stage VII

Checking the possibility of performing the work by the machine aggregated with the tractor.

a. Trial aggregation for performing the jobs in accordance with the purpose of the machine and with obligatory observance of the safety requirements.

b. Checking the fitting of the tractor within the row-spacing of the crops to be cultivated with determining:

- the correspondence of track and tyre profile width;
- agrotechnical clearance;
- protective zones to the tyres.

Stage VIII

Checking the total cross-country ability, static stability on slopes and efficiency of brakes under local conditions:

a. possibility of overcoming the ups and downs by the tractor with the machine loaded with process material;

b. possibility of motion along the slope.

Assess the clearance value and steerability of the tractor aggregated. During the motion, the front wheels of the tractor shall not be taken off the road surface. The front axle of the tractor shall perceive at least 20% of the load (steerability criterion $K_s \geq 0.2$) from its own operating weight in any case of its use.

Stage IX

Carrying out the control shifts for the purpose of determining the operating characteristics:

- a. time and labour intensity of forming the MTA;
- b. average operating speed;
- c. productivity per 1 hour of basic (shift, operating time);
- d. volume of the work performed for the reference time;
- e. hourly (specific) fuel consumption.

Checking the correctness of forming the machine-tractor aggregate

The operation of the tractor with the aggregated machines being either overloaded or underloaded shall not be allowed. In the first case, there will be increased wear of the parts of the tractor, excessive fuel consumption and decrease of the productivity of the aggregate while in the second case there will decrease of the economic characteristics and, particularly, productivity and increase of the fuel consumption.

Therefore, the tractor driver shall first of all make sure that the MTA has been formed correctly and its recommended speed in the most favourable.

In the tractor operation there are **two main speed modes**: operating motion speed and near-transport speed (in idling when performing the turns and motion to another place) with the tools disengaged. The main of these modes is the operating speed, the variation of which affects the quality of performing the job in accordance with the agrotechnical requirements. The operating manuals for individual machines contain the allowable operating speed ranges. Any variation of the working motion speed of the tractor with the aggregated machine including the operating manoeuvring during the operating motion is only allowable within the limits to be determined by the agrotechnical requirements. The initial operating speed is set usually within these limits together with the machine grasp width. The speed mode of the tractor with the machine in the near-transport mode is generally limited by the safety requirements. Due to relatively short duration of the turns and necessity of following the guidelines for limitation the transport speed when moving from one field to another, the respective tractor speed in the mode is often close to the operating one.

If the machine to be aggregated has been selected, it is only necessary to determine the operating speed and respective gear.

The operating speed of the tractors during the operation under field conditions is limited first of all by the quality of the work to be performed. Besides, for traction machines it is limited by the tractive and hitching capabilities of the tractor and for traction and driven aggregates – by the allowable power of the PTO and hydraulic takeoff as well as by the through-put capacities of the machine tools.

Checking the correctness of formation of the aggregate according to the rotational speed of the engine crankshaft. In practice, the operating motion speed of the tractor is selected based on the tachospeedometer readings. While knowing the range of agrotechnically allowable speeds, the tractor gear (motion speed), in which the tractor shall enter this range is determined.

The normal load on the tractor should be considered such a load, at which the readings of the crankshaft rotational speed on the tachospeedometer would be lower (by not more than 6%) than the rated value specified in the manufacturer's documentation. Drop of the rotational speed by the value exceeding 6% indicates the engine overloading. The increase of the rotational speed above the rated one indicates the engine underloading.

The main condition of the optimal aggregation of the BELARUS tractor is proper use of the engine power which is characterized by the load factor expressing the degree of use of the tractor's rated power for performing the jobs by the aggregated agricultural machines. For each group of agricultural operations exist objectively the approximate values of the degree of use of the engine's rated power.

The correctly selected operating mode of the tractor is understood as such aggregation of the tractor with observing all the operating rules and limitations, which ensure not only performance of the work in accordance with the agrotechnical requirements for the working operation to be performed, such as engine loading mode, speed mode of the aggregate, allowable skidding mode as well as compliance with all the recommendations for safe use of the tractor (speed selection, loading modes).

The engine loading degree can be varied by increasing or reducing the number of machines, varying the grasp width, operating depth as well as motion speed in the process of the operating motion of the aggregate. If the efficient loading of the engine by varying the number of machines and operating speed is impossible, the respective partial operating mode should be chosen by reducing the fuel feed.

The engine loading degree is determined from the crankshaft rotational speed. It is necessary to work at the crankshaft rotational speed exceeding slightly the rated value (indicated on the tachospeedometer). If the operating speed is below the required value, a lower gear shall be put in.

Allowable skidding mode. One of the main special requirements consists in observance of the allowable skidding limits: 16% for wheeled tractors with two driving axles and up to 18% for wheeled tractors with one driving axle. The MTA shall be completed and the speed mode shall be selected within the limits of allowable skidding. Excessive skidding of the tractor propulsion devices causes the destruction of structural particles of the soil with subsequent development of the wind and water erosion.

4. Using the rear mounted attachment and hydraulic system

The rear mounted attachment of the standard size HY-2 is manufactured according to State Standard ГОСТ 10677 (corresponds to category 2 according to ISO 730/1). The main parameters of the rear mounted attachment specified in the technical data are given for fitting the tractor with the standard size of the basic tyres with the standard static radii specified by the tyre manufacturer.

The rear mounted attachment consists of three rods (one upper and two lower ones) the front ends of which are coupled by means of joints with the tractor and the rear ends of which are coupled with the free joints for connecting with the link pins of the aggregated machines. It is intended for coupling the rear-mounted machines to the tractor, transmission of tractive force during the operation and adjustment of their position during the operation or motion in the transport state.

The mounted attachment provides the aggregation of the following types of the machines and implements:

- mounted ones using the three-point mounting (upper and lower rods);
- semi-mounted (lower rods);
- semi-trailed using the crossbar on the mounting axle (lower rods).

The external limit rods with adjustable length serve for preventing the attached machines from swinging.

The following adjustments of the rear mounted attachment in the vertical and horizontal planes by means of the upper rod, braces and limit rods are provided for ensuring the required position of the machine:

A. Altering the length of the upper rod

- equal penetration (equalizing the depth of travel of the tools located one after another in the direction of the tractor motion); if the frame of the mounted plough is tilted forward as seen in the direction of the tractor motion and the front plough body ploughs deeper than the rear one does, elongate the upper rod and shorten the same, if the front body ploughs with less deeply than the rear one does.

B. Altering the brace length.

- position of the machine in the horizontal plane;
- uniform operating depth provided by the tools of the mounted machine over the grasp width;

Important: The length of the left brace of the mounted attachment is **475** mm and not to be altered without special necessity, usually the length of the right brace is to be adjusted. When using the crossbar on the mounting axle and operating one-way ploughs, the length of the braces shall be equal.

D. Altering the length of both braces and upper rod for the transport position of the machine.

- clearance: at least 300 mm;
- sufficient safe distance between the members of the tractor and those of the machine excluding the contact of the machine members with the tractor (the clearance shall be at least 100 mm).

E. Altering the length of both braces

- when transporting the machine (with the top position of the mounted attachment), the limit rods shall be shortened to the maximum extent within the existing adjustment for limiting the swinging of the machine during the motion to avoid the damage of the tractor members in possible emergencies;

- when operating the mounted and semi-mounted soil cultivating machines with passive tools intended for overall tillage (share and chisel ploughs, stubble-breaking ploughs, deep tillers and other machines), it is necessary to ensure the free motion (swinging) of the lower rod in the horizontal plane to the distance of 125 mm to each side from the longitudinal plane of the tractor unblocking the limit rods; no limitation of the grasp width by means of the rods is allowed;

- when operating agricultural machines (except for ploughs, deep tillers and other similar machines for overall tillage of the soil with passive tools), ensure a partial blocking to limit the swinging of the lower rods in the horizontal plane to not more than 20 mm.



Failure to follow the recommendations for adjusting the limit rods and braces can cause the rupture of the rods and support brackets or other breakages.

C. Adjusting the brace

During the operation, the braces are connected usually with the lower rods through the holes in the brace forks.

To improve the transversal contour following (cultivators, sowing machines, etc.) and reducing the loads on the mounted attachment during the operation with the wide-coverage machines, it is necessary to ensure the free movement of one lower rod in the vertical plane relatively to another rod. To do this, it is necessary to adjust the braces in such a way that a free movement of one lower rod in the vertical plane relatively to another rod would be achieved. Such adjustment is ensured by connecting the braces through the slots.

The rear mounting attachment is controlled by moving the respective hydraulic distributor control levers from the cab as well as by the external pushbutton panel which provide the positioning of the lower rods of the rear mounted attachment to the necessary height. The method of adjustment of the position of the rear mounted attachment is selected by the tractor driver in the manual mode by turning the handle for selecting the adjustment method on the control board of the rear mounted attachment.

Attention!

The necessary peculiarities and method of adjustment of position of the machines aggregated by means of mounted attachments in accordance with the peculiarities of performing the job and agrotechnical requirements are given in the operation documentation for the machines. If such data are unavailable, obtain obligatorily the necessary information from the manufacturer or seller of the machine.

The universal hydraulic system for controlling and adjusting the mounted attachments of the tractor provides additionally the following functional capabilities for the rear mounted attachment:

- correction of the speed of lifting and lowering the lower rods;
- restriction of the height of lifting the lower rods;
- selection of the necessary method of adjustment of position of the lower rods;

- correction of the operating depth;
- possibility of operation with the machines provided with height-related method of adjustment of the height of travel of the tools (the depth is adjusted by the carrier wheel of the machine).

The hydraulic system provides the following methods of adjustment of the position of the mounted and semi-mounted machines and their tools:

a) having no carrier wheels:

Power: the depth is adjusted in accordance with the draught resistance of the machine;

Position: the machine is held in the specified position relatively to the tractor body;

Combined: the power and position methods in any relationship;

b) provided with carrier wheels:

Combined: the power and position methods in any relationship.

The hydraulic system for controlling the mounted attachments ensures the possibility of additional oil takeoff for providing the operation of the aggregated machines.

The tractor is provided with free hydraulic outlets for servicing the aggregated technical means by means of the applied high-pressure hoses.

The oil consumption is 35...45 l/min (depending on the technical state of the hydraulic pump). The oil takeoff by the hydraulic cylinders of the aggregated machine shall not exceed 16 l. The level in the hydraulic oil tank should be checked with the plugs of the working cylinders retracted.

The shutting off and rupture members included in the spare parts and accessories kit of the tractor (optionally) are provided for preventing the losses of oil when aggregating the technical means or unforeseen disconnection. The hydrostatic power intake is possible through one of the outlets for supplying the special-purpose hydraulic motors. To avoid the overheating of the hydraulic system, the work pressure shall not exceed 11 MPa (110 kgf/cm²) that corresponds to the power of 11 kW, not more. A separate pipeline (optional) is provided for draining oil from the hydraulic motor with bypassing the distributor.

The tractor is equipped with fittings having the conditional flow passage $D_c = 12$ mm and connection thread M20x1.5. In case of necessity of connection of the aggregated machines with different thread, the required adaptors with the conventional flow passage of at least $D_c = 12$ mm should be manufactured.

ATTENTION! The oil in the working cylinders of the aggregated machine shall be clean and correspond to the brand used in the tractor. Failure to fulfil these requirements can cause failure of the hydraulic units of the tractor.

The adaptation and modification of the structural elements of the hydraulic system of the tractor except for those permitted by this Operating Manual is only allowed after consultation with the manufacturer.

5. Using the traction hitching mechanisms

The tractor can be equipped with traction hitch mechanisms of various types providing the aggregation of trailed and semi-trailed machines, the coupling arrangements of which meet the following requirements:

- compatibility of the coupling dimensions;
- the machines are provided with fixed drawbars;
- the trailer hitches are equipped with a device facilitating the coupling of the trailer with/uncoupling of it from the traction hitch device of the tractor;
- the hitches of the semi-trailers are fitted with adjustable support.

The tractor is equipped with a rear lifting device in the form of vertical guiding plates. The device is intended for fastening the traction hitching mechanisms TCY-2 and TCY-3 of the design provided by the manufacturer.

It makes it possible to reposition the connection link of the traction hitch device to the height and facilitated the dismantling.

The traction hitch mechanism TCY-1 (the crossbar is on the mounting axle of the mounted attachment HY-2) is only intended for aggregating with semi-mounted and semi-trailed machines for performing the jobs at the speed of ≤ 15 km/h. The crossbar has a number of holes for connecting. The normally aggregated machine is coupled through the middle hole of the crossbar.

In case of necessity of matching the track of the tractor with the aggregated machine (mainly harvesting) with insignificant draught resistance, an asymmetric connection is allowed. The crossbar shall be acquired to the consumer's order.

6. PTO and drive of the machines

The design and location of the rear power takeout (PTO) of the tractor complies with the international standards. Therefore, in case of correct location of the machine's power intake shaft (PIS) relatively to its coupling link, the cardan shafts of the standard design can be used.

The tractor is provided with the PTO shank 3 and PTO shank 4 (included in the spare parts and accessories kit) for driving machines from the complete set of tractors of the K-700 type or from the complete set of tractors belonging to the drawbar category 3 in the mode of 1000.0 rpm. There is an economical PTO mode making it possible to ensure the shank rotational speed of 1000 rpm in the partial operating mode at the rotational speed of the engine of 1435.0 rpm.

The parameters of the PTO shanks are given in Table 6; the characteristic of the PTO drive is given in Tables 2 and 3.

Attention!

1. For providing the protection of the PTO drive, it is expedient to equip the machine with a protective coupling.
2. To avoid the overloads of the PTO drive when aggregating with the inertial machines (fodder harvesters, etc.), it is necessary to use the cardan shaft with the overrunning clutch on the PIS side.
3. The working torque on the cardan shaft shall not exceed the allowable torque on the PTO.

The rear PTO of the tractor is provided with the shank of the type BOM1/BOM1C/BOM2.

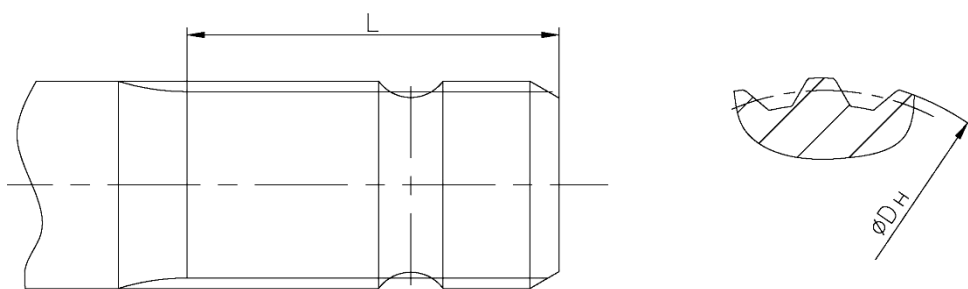

Fig. 2

Characteristics of the PTO drive

Table 2

Characteristic	Designation	PTO 1	PTO 1C	PTO 2
Spline length, mm	L	76	78	64
Outer diameter, mm	DH	35	38	35
Number of splines	n	6	8	21

Table 3

PTO	Shank type	Rotational speed, rpm		Transmitted power, kW (h.p.)
		of the PTO	of the engine	
Rear separate PTO	PTO 1C	540	2081	58.8 (80)
	PTO 1	540	2081	
	PTO 2	1000	2081	
Rear synchronous	BOM1C BOM1 PTO 2	3.4 revolutions/1 m of travel		

7. Installation of the cardan shaft

Installation of the cardan shaft with the protective cover fitted with a protective apron of the PTO ensures the safety of the coupling (a).

The end yokes shall be in the same plane (b)

Table 4 (c)

PTO	Angle of tilting of the cardan joints (degrees, not more than)	
	Universal	Of equal angle speeds
Engaged	22.0	25.0 (50 for short

		term)
Disen- gaged	55.0	55.0

Overlapping the telescopic elements of the cardan shaft shall be at least 110...200 mm to avoid the disconnection and jamming of the coupling (d).

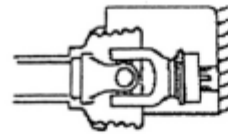

a)

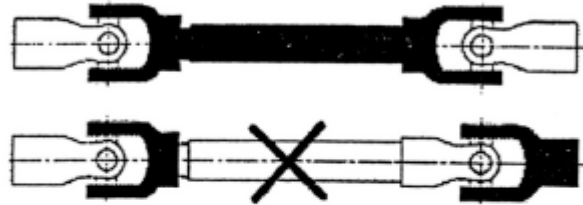

b)

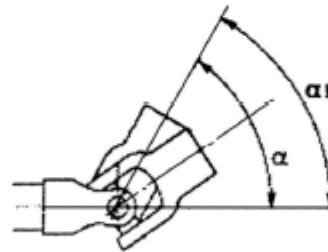

c)

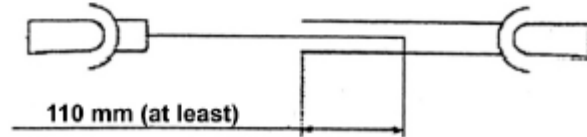

d)

8. Determining the weight of the tractor, machine and ballast, loads on the traction hitch mechanism and mounted attachment, tyres and axles of the tractor and steerability criterion

The tractor and its structural members including also tyres are designed for trouble-free operation in a certain range of vertical loads and speeds specified in the Operation Manual for the tractor. In case of failure to follow the recommendations concerning the loading and speed modes of the tractor and tyres, the manufacturer does not guarantee its trouble-free operation and warns about inadmissibility of such operation. Each pneumatic tyre is designed for operation within a certain range of vertical loads. The width of this range is determined by the size and design features of the tyres.

The most accurate and reliable method of determining the weight and loads consists in weighing on the balance for motor transport means.

Attention!

The load on the mounted attachment, traction hitch mechanism, axles, tyres and body of the tractor from the weight of the aggregated machines shall not exceed the maximum allowable values specified by the manufacturer. Here the load on the front axle of the tractor in every case of its use shall be always at least 20% of the own operating weight of the tractor without ballast weights and water solutions in the tyres.

The practical determination of the weight of the tractor and machines and vertical loads on the axles of the tractor is performed usually on any suitable balance having an appropriate capacity and intended for heavy-load motor transport means. Weighing on the balance makes it possible to determine also the real load on the coupling arrangements of the trailed, semi-trailed and semi-mounted machines.

The value of vertical loads on the coupling arrangements of the trailed, semi-trailed and semi-mounted machines can be determined by means of a special dynamometer. **It is not recommended to use a dynamometer for determining the load on the front and rear axle due to large weight of the tractor.**

Important: To determine the load on a certain axle of the tractor by means of a balance, the tractor shall be placed so that the wheels of the axle to be measured would be on the balance platform and the wheels of another axle – outside the weighting zone at the same level with the platform. We recommend measuring the load on a separate axle of the tractor within a MTA using the following technique:

Standard equipment A: Tractor with a rear-mounted machine or mountable ballast weights; the front mounted attachment is not used.

- the front axle (with the rear mounted attachment lowered) is weighed;
- the rear axle (with the rear mounted attachment lifted) is weighed.

Standard equipment B: Tractor with a front-mounted machine or mounted ballast weights; the rear mounted attachment is not used.

- the front axle (with the front mounted attachment lifted) is weighed;
- the rear axle (with the front mounted attachment lowered) is weighed.

Standard equipment C: Tractor with the front and rear machines and mounted ballast weights.

- the front axle (with the rear and front mounted attachments lifted) is weighed;
- the rear axle (with the rear and front mounted attachments lifted) is weighed.

The value of the load on the coupling arrangement of the machine can be determined using the following two methods:

1. On a balance.

The machine is placed on the balance in such a way that there would be only coupling arrangement of the machine on the balance with the support of the hitching loop (as regards the trailed and semi-trailed machines) or mounting axle (as regards the semi-mounted machines) resting upon the platform through a stand with the weight of less than 50 kg and height of 300...500 mm, while the remaining (major) portion of the machine would be outside the weighing zone. The load on the coupling arrangement of the machine can be only determined on a platform balance provided the length of the coupling arrangement is sufficient to place the machine outside the weighing zone.

2. By means of a dynamometer.

The load on the coupling arrangement of the machine can be determined by weighing the coupling arrangement on a beam crane through a dynamometer.

Allowable loads T on the axles of the tractor:

Axle	Range of the loads, min....max, kN
Front	T _f =8...35
Rear	T _r =16...50

but not more than the total load-carrying capacity of single tyres of rear or front wheels.

In case of twinning the wheels with the tyres of the same or different standard sizes, their total load-carrying capacity shall be reduced by 20%.

In case of setting the wheel track exceeding 1800 mm, the loads on the axles shall be reduced by 5% per each 100 mm of increase of the track.

In every case, the total load on the tractor wheels shall not exceed $T_f + T_r \leq 70$ kN. (7000 kgf)

The soil compaction depends considerably on the number of passages of the MTA on the track. Therefore, it becomes expedient to reduce the number of passages at the cost of combining the operations by means of combined aggregates.

Twinning the wheels makes it possible to reduce considerably the specific pressure on the soil and preserve the soil structure, especially, on moistened fields.

Twinning the wheels on dense soils makes it possible to improve the tractive and hitching capabilities of the power source, especially in combination with correct ballasting or loading of the tractor.

The steerability criterion K_s is determined from the formula:

$$K_s = (m_f \cdot g) / M_T \cdot g \geq 0.2,$$

where $g=9.8$ m/s; m_f is a value of a portion of the operating weight of the tractor within the MTA perceived by the front axle of the tractor, kg; M_T is the standard operating weight of the tractor, kg.

9. SELECTING THE MOTION SPEED

The speed of motion of the tractors on public roads can be limited by the technical possibilities of the tractor and aggregated machine in accordance with the sign provided on the technical mean, characteristics of the machines (method of aggregation, overall dimensions, operating weight and absence of the braking system) as well as motion conditions.

Table 5

Work to be performed by the tractor	Aggregation peculiarities	Motion speed, km/h, not more than	Remarks
1. Towing the trailers and semitrailers	The tractor is only ballasted with standard basic or additional front and wheel weight manufactured by the Minsk Tractor Works Republican Unitary Enterprise		Selection of the traction hitch mechanisms for the aggregation is determined by the coupling dimensions and allowable static vertical load on the hitch mechanism of the tractor
a) on public roads		30.0	
b) under field conditions and on roads without category		20.0	
2. Transfer of the agricultural machines to the place of operation and movement within machine-tractor aggregates from one field to another			
a) by means of the traction hitch mechanisms TCY-1M, TCY-2 and TCY-3	The machine is equipped with the service brake system	30.0	The machine weight is not more than 6000 kg
		20.0	The machine weight is over 6000 kg
	The machine is not equipped with the service brake system	20.0	The machine weight is not more than 6000 kg
		15.0	The machine weight is over 6000 kg
b) by means of the traction hitch mechanisms TCY-1, TCY-1Ж-01		15.0	
c) by means of the HY-2		20.0	The weight of the tractor within the MTA is not more than 5500 kg
		15.0	The weight of the tractor within the MTA is over 5500 kg
d) twinned rear wheels of the tractor		20.0	
e) twinned front wheels of the tractor		15.0	
f) Solution in the tyres of the tractor's wheels			
- front		10.0	

- rear		15.0	
3. Motion on slopes and sharp turns; overcoming obstacles		10.0	
4. Performing the agricultural-purpose jobs		1.94...15.6	When selecting the working motion speed, it is necessary to follow the agrotechnical requirements for performing the job by the machine with the account of the working conditions, allowable tractor speed range and recommendations of the manufacturer of the tractor and the machine.

10. Safety of aggregation of the tractor

To ensure the trouble-free operation of the tractor and aggregated machines as well as to exclude accidents and emergencies, we recommend you to read carefully this Operating Manual for the tractor and follow strictly the recommendations contained herein at any time. Observe strictly all the safety recommendations and accident prevention regulations.

Failure to observe the accident prevention regulations can cause the threat for the life and material damage due to breakdown of the tractor or aggregated machine and loss of all the rights for the compensation for damages including that according to the warranties. Do not risk your health or life due to failure to observe the accident prevention regulations. The worker shall not be allowed to operate the tractor including aggregating the machines with it or perform its maintenance unless he/she has read and understood **ALL** the guidelines concerning the operation of the tractor and accident prevention regulations.

Attention!

The operating documentation (concerning both the tractor and the aggregated machine) shall be stored obligatorily in the cab so that it could be used in case of arising of any questions during the work. If the Operating Manual for the machine or tractor is lost, acquire a new one without delay.

Below are stated the accident prevention guidelines, which shall be observed rigorously when aggregating the tractor with various machines, but are often unconsciously ignored by you during the everyday use of the tractor and machines.

10.1. MOTION ON PUBLIC ROADS AND TRANSPORTATION WORKS

Actually for the half of the time of its operation, the tractor is used for transporting purpose with driving to public roads. Therefore, the transport MTA's are subject to exclusive safety standards. The vehicles such as tractor trailers or semitrailers shall be equipped with service and parking brakes and safety chains (ropes).

The load-carrying capacity of the vehicles (trailers, semitrailers, fertilizer distributors and spraying machines) depends on the relief of the locality, slope and condition of the roads. With the account of the allowable longitudinal slope of 12 degrees, the total weight of the semitrailer (trailer) equipped with brakes shall not exceed 9000 kg and that on relatively flat area (with the slope of less than 4%) with dry hard road pavement – not more than 12000 kg.

The tractor's track value shall correspond to the conditions of the works to be performed, technical characteristics of the tractor and ensure the safe use of the tractor within machine-tractor aggregates. When driving the tractor on the slopes and sharp turns increase the tractor's track for increasing the stability.

The service brake actuator is made as a single-wire scheme which is controlled from the workplace of the tractor operator. The parking brake actuator shall be located on the machine.

Aggregation of the general-purpose vehicles (trailers and semitrailers) shall be made through the traction hitch mechanisms TCY-2 or TCY-3. For the safety reasons, the coupling with the traction hitch mechanisms TCY-1Ж and TCY-1 is strictly forbidden.

On rear left part of the machines such as trailers or semitrailers there shall be a sign of limitation of the maximum speed of the MTA. The hole with the diameter of 24 mm in the both cheeks of the lifting device serve as a place of attaching the safety chains (ropes) on the tractor (the fasteners are included in the standard equipment of the technical mean to be aggregated).

The tractor aggregation with the train (tractor + semi-trailer + trailer) is only allowed on dry roads with hard pavement and slopes not exceeding 4%. When driving to the public roads, the overall dimensions of the MTA shall not exceed: width – 2.6 m and height – 3.2 m.

In case of deviations from the provided norms, the consultation with the state authorities responsible for the traffic safety is required.

IMPORTANT! When performing the transportation works on the roads with hard pavements, increase the pressure in the tyres to the maximum value allowed by the manufacturer.

To connect the signaling equipment of the facilities to be aggregated, the tractor is provided with a receptacle with the socket for supplying the instruments of the aggregated machine.

When driving the tractor on the public roads follow the following requirements:

- 1) The forward motion shall be only performed with the flashlight beacon switched on;
- 2) The reverse motion on the public roads is not allowed, because the light signalling devices are only oriented to the forward motion;

- 3) Using the working lights is not allowed because it causes the dazzling of other traffic participants;
- 4) The motion of the tractor aggregated with agricultural machines with the vessels filled (process material – fertilizers, seeds, etc.) on public roads is prohibited.

10.2. On the intended use of the tractor and machines within the MTA

- The tractor and machines either separately or within the MTA should be only used in accordance with their purpose as specified in the operating documentation for them, under the conditions and in the modes specified by the manufacturer. Using the technical means including of the tractor for any other purposes is considered to be unintended use. The manufacturer shall bear no responsibility for damages caused due to such use of the aggregate. In this case, the total responsibility shall be born by the user.

- The concept of “*intended use*” includes also meeting the conditions of the operation, maintenance and care specified by the manufacturer. The use, maintenance and care of the tractor and machines shall be carried out by the personnel appointed for this purpose and informed duly about the potential hazard.

- Observe the existing accident prevention prescriptions, such as commonly known safety regulations, medical recommendations for labour protection and road regulations.

- Any unauthorized modification of the construction of the aggregate releases the manufacturer from the responsibility for the damages caused by such modification. It is equally applied to the cases where faulty units have been improperly dismantled or repaired, the tractors or machines without full standard equipment or equipped otherwise than it is provided by the technical specifications have been used as well as where the original manufacturer's parts and assemblies have been replaced by other special or unoriginal ones not provided for by the manufacturer or where the seals are broken.

10.3. General guidelines for observing the aggregation safety precautions

- Prior to beginning the work, check every time the tractor within the MTA for the motion and operation safety.

- Follow all the existing prescriptions concerning the safety precautions and accident prevention as specified in the instructions for labour protection.

- The plates attached to the machines aggregated contain the warnings and important guidelines for safe operation.

- Observe the traffic regulations.

- Prior to beginning the work, become familiar with all the parts and assemblies of the aggregated machine, control elements and functions to be performed. It would be too late to do this during the work!

- The clothes of the persons working on the tractor shall be tight-fitting. Wearing free clothes is not allowed!

- To prevent a fire, keep the tractor and machines clean!

- Prior to starting the tractor and beginning of its operation, make sure that nobody is present near the tractor and machines. Take care of good vision from all the sides. Pay special attention to children.

- The machines shall be coupled with the tractor in strict compliance with the operation manuals. When doing this, use only recommended methods and equipment for aggregating.

- Be especially careful when connecting the machines to and disconnecting them from the tractor. When connecting or disconnecting the technical means, make sure that the used supporting facilities are positioned properly (assess the stability!).

- Mount the ballast weights and counterweights only in the fastening points provided for

this purpose in accordance with the recommendations.

- Observe the allowable values of the vertical static loads on the axles, tyres, total operating weight and dimensions in the transport position!
- Check the condition of the transport equipment of the machines (lighting set, warning and safety devices). Mount this equipment on the machine!
- The disconnecting ropes for the rapid-action coupling shall hang freely and shall not become disconnected simultaneously in the bottom position.
- During the motion, it is forbidden to leave the cab of the tractor!
- The machines coupled with the tractor as well as ballast weights affect the transport characteristics, steerability and braking capability. Keep it in mind when driving and braking the tractor, especially within the MTA. Observe the distance! Take into account the possibility of skid, overhang and inertial mass of the aggregated machines in the turn!
- The tractor with the machines shall be only driven provided all the safety facilities of the machines are installed and brought to the appropriate working position!
- It is strictly prohibited to be in the working zones of the machines! It is prohibited to be in the zones of turning or revolution of the machines, their tools and other elements!
- The hydraulically folding frames of the machines shall be only actuated when there are no people in the turn or lifting zone!
- The remotely controlled elements of the machines (for example, having hydraulic control) can cause injuries (squeezing and cuts)! During the movement of the aggregate at high speed, the driven tools cause danger due to possibility of their extension under the action of their inertial mass! Wait until the tools are completely stopped!
- Prior to leaving the cab of the tractor, lower all the machine elements to the ground, stop the engine and remove the ignition key!
- It is strictly prohibited to stand in the zone between the tractor and the machine, unless the transportation mean is secured against accidental rolling down by means of a parking brake and/or chock and the engine is stopped!
- The folding frame and bucket of the loader shall be secured in the transport position!
- Prior to starting the transportation on public roads, the swinging lever of the additional equipment of the machines, for example, packing wheel shall be turned inwards and fixed! The markers shall be also fixed in the transport position!
- The loading platform on the machine aggregated shall be only used for filling the machine with planting material and fertilizers! It is strictly prohibited to stand on the platform during the work!
- When driving the tractor on slopes and sharp turns, the track should be increased for improving the stability.

10.4. Mounted and semi-mounted machines

- Prior to aggregating the machines by means of the three-point mounted attachment as well as prior to disconnecting the machines from the three-point mounted attachment, the control of the above attachment should be set to the position excluding the unintended lifting or lowering of the aggregate!
- When connecting the machine to the joints of the three-point mounted attachment, ensure the matching of sizes of the respective connecting members (category or type: tractor + aggregate)!
- The stay in the zone of the three-point mounted attachment is dangerous due to probability of serious injuries such as squeezing and cuts! When exercising the remote control during the mounting of the machine on the three-point mounted attachment, it is strictly prohibited to stand in the zone between the tractor and the aggregate!
- Ensure the reliable side fixation of the lower rods of the three-point mounted attachment of the tractor by means of rod, if the aggregate is in the transport position! When driving the tractor on public roads with the machine in the transport position or lifted aggregate, secure the three-point mounted attachment in the top position to prevent the aggregate from spontaneous lowering and ensure the sufficient clearance between the machine members and road (at least 300 mm)!

10.5. Trailed and semi-trailed machines

- Take measures excluding the involuntary rollback and movement of the machines fitted with the transport wheels!
- When connecting the trailed or semi-trailed machine to the tractor, ensure the matching of the sizes of the respective coupling members of the tractor and the machines!
- Observe the maximum allowable vertical static load on the traction hitch mechanisms of the tractor!
- When using the single-point hitch of the agricultural machines by means of the hitching loop (hitch bar or tongue), ensure the necessary mobility at the connection point and exclude the possibility of jamming!
- The single-point coupling arrangement (hitch bar or tongue) of the machine shall have a support and safety connecting chain or rope.
- The coupling arrangement of trailed and semi-trailed machines shall be stiff to exclude the collision of such machines with the tractor.

10.6 For the machines driven from the PTO

- Only use the cardan shafts, which are recommended by the manufacturer of the machine! Inspect regularly the technical condition of the cardan shaft.
- The cardan shaft shall have an appropriate protective cover! The cover of the cardan shaft shall be secured against turning by means of a chain!
- Prior to connecting or disconnecting the cardan shaft, disengage the power takeoff, stop the engine and remove the ignition key!
- Control at all times the correctness and safety of installation of the cardan shaft!
- Prior to engaging the power takeoff, make sure that the selected rotational speed of the tractor's power takeoff does not contradict the allowable rotational speed of the aggregate!
- When using the synchronous power takeoff, make sure that the rotational speed depends on the motion speed and the rotation direction changes of opposite when reversing!
- Prior to engaging the power takeoff, make sure that no people are present in the dangerous zone of the aggregate!
- Never engage the power takeoff when the engine is stopped!
- When working with the power takeoff, make sure that there are no people in the zone

of rotation of the power takeoff and cardan shaft!

- Disengage at all times the power takeoff when beginning driving on a step slope as well as in cases where its operation is unnecessary!
- After disengaging the power takeoff, the hazard due to the inertial mass remains for some time. Do not approach the connected machine during this time! Performing any works is only allowed after complete stop! Stop obligatorily the engine and remove the ignition key!
- Cleaning, lubricating or adjusting the aggregate driven from the PTO or cardan shaft shall be only performed provided that the power takeoff is disengaged, the engine is stopped and the ignition key is removed!
- The disconnected cardan shaft shall be secured on the respective bracket!
- After removing the cardan shaft, fit the protective cover to the end of the power take-off!
- Inspect visually the cardan shaft, power takeoff and power intake shaft. Eliminate immediately the faults revealed!

10.7. Rules concerning the pressurized instruments and mechanisms of the machines and tractor

- Caution! Do not forget about the presence of high pressure in the hydraulic and pneumatic systems of the tractor and machines aggregated!
- When connecting the hydraulic cylinders and hydraulic motor from the complete set of the machine, check the correctness of connection of the hydraulic hoses!
- Prior to beginning connecting the hydraulic hoses to the hydraulic system of the tractor, make sure that the hydraulic circuits of the tractor and aggregate are depressurized!
- When performing the hydraulic connection between the tractor and the machine, it is necessary to mark beforehand the components to be connected in order to avoid errors in the control of the units of the hydraulic system of the aggregated machine! Erroneous connection of the reverse function (for example, lifting or lowering) can cause an accident!
- When connecting the hydraulic hoses of the machine to the tractor's hydraulic system, make sure that the system is depressurized; observe the correctness of the connections between the hydraulic system of the tractor and the hydraulic system of the aggregate in accordance with marking the hoses and connecting diagram. The connecting diagram shall be given in the Operation Manual for the machine.
- Check regularly the condition of the hydraulic hoses. Should any damages or ageing signs be revealed, the hoses shall be replaced without delay! The new hoses intended for substituting the old ones shall comply completely with the manufacturer's requirements!
- To avoid injury when determining the leakage places, use appropriate aids! A liquid (hydraulic oil) flowing out under pressure can penetrate under skin and cause heavy injuries! In case of injury, call immediately for medical aid! Hazard of blood poisoning!
- Prior to beginning the work with the use of the hydraulic system of the tractor, lower the machine, depressurize the hydraulic system, stop the engine and remove the ignition key!
- Any works with the hydraulic and pneumatic connections of the hydraulic accumulators and receivers of the machines shall be performed with the pressure released!
- Improper installation and operation of the hydraulic accumulators with violation of the labour protection requirements can become a cause of heavy accidents.

10.8. Tyres, braking system

- Caution! Do not forget that the pneumatic systems of the tractor and aggregated machines contain high pressure.
- Each time prior to departure check the intactness and operability of the brakes!
- The brake system shall be regularly and thoroughly controlled! The braking system shall be only adjusted and repaired by a qualified specialist or reliable service department! Use the recommended brake fluid only! Pour the brake fluid in accordance with the operating documentation!
- When operating the machines with transport wheels, it is necessary to ensure the stable position of the machine (wheel chocks!) to prevent the involuntary rollback!
- Fitting the tyres requires appropriate habits! It shall be performed by means of special fitting tools!
- The repair works on the tyres and wheels shall be only performed by a qualified specialist with the use of appropriate fitting tools!
- Monitor regularly the pressure in the tyres! It shall correspond to the specified norms!

10.9. Maintenance and repair of the machine-tractor aggregates

- The repair, maintenance, cleaning as well as elimination of functional faults shall be performed on obligatory condition that the hydraulic system, driving mechanisms and engine are stopped and the ignition key is removed!
- Check regularly the degree of tightening of bolts and nuts! If necessary, retighten them! Pay attention to the fasteners of the tractor body, wheels, coupling arrangements including the traction hitch mechanisms and three-point mounted attachments.
- Do not perform welding, brazing or mechanical works on the hydraulic accumulators.
- When performing the maintenance works on the lifted machine, ensure the stable position of the machine by means of the respective supporting structures!
- When replacing the tools of the machines having sharp cutting edges, it is necessary to use appropriate tools and gloves!
- The oil, grease and filters shall be disposed of appropriately!
- Prior to commencement of the maintenance works and repair of the electric equipment, disconnect obligatorily all the electrical instruments and devices!
- When performing the electric welding on the tractor and machine, set the battery disconnect switch to the OFF position and disconnect the cable and bundles from the storage batteries and alternator.
- Storing the gas implies high risk of explosion!
- The spare parts for the tractor and machines shall comply completely with the manufacturer's specifications! To ensure your safety, use original spare parts!

10.10. Additional guidelines for safety of aggregation

- The tractor is a high-technology product and belongs to the category of motor vehicles covered by the road regulations and other normative documents regulating the operation of railless transport.
- When reading the Operating Manual for the tractor, pay special attention to the recommendations for selecting the motion speed and maintaining the allowable loads on the traction hitch mechanism, mounted attachment, axles and tyres of the tractor. The possibility of safe motion of the tractor with satisfactory steerability and stability is evaluated by the **steerability criterion**, which is characterized by the ratio of the value of the load on the front axle of the tractor to its standard weight. The steerability criterion is determined by calculation.
- The aggregation of the technical means with the tractor is prohibited, if the value of

the vertical static loads on the axles, tyres, traction hitch mechanism and mounted attachment of the tractor obtained from the results of weighing, calculations and ballasting exceeds the allowable values specified in the Operating Manual for the tractor.

- To ensure the steerability, stability and stable traction, hitching and braking capabilities, especially, on the areas of fields with slopes and on soft soils, we recommend providing the load on the front wheels of the tractor within the MTA 25...40% of the standard operating weight of the tractor.

- **To ensure your safety** and prevention of operational failures and breakdowns of the tractor, it is necessary to perform the following actions:

- Determine the value of operating weights of the tractor, machine and process material.

- Determine the loads on the axles and tyres of the wheels of the tractor.

- Test the tractor within the MTA for compliance with the requirements for the minimum allowable load on the front wheels of the tractor with the machines in the transport position, allowable loads on the traction hitch mechanism, axles and tyres of the wheels, required load-carrying capacity of the mounted attachment for lifting the machine and total maximum load on the tractor axles.

- Ascertain the possibility of aggregation of a specific aggregate or machine from the results of weighing.

- Select the minimum necessary weight of the ballast.

- Determine the degree of loading the machine with the process materials ensuring the safe operation of the tractor.

- Determine the necessity of twinning the wheels and filling the tyres with water solution.

- Assign the required pressure in the tyres depending on the maximum load and speed under specific working conditions. The value of separate loads on the front and rear axles of the tractor within the MTA shall not exceed the total allowed load-carrying capacity of the front and rear tyres of the tractor, respectively, at the given speed and internal pressure as specified in the Table of load-carrying capacity of the tyres.

ADJUSTMENTS

HPS with a cylinder in steering trapezium

The optimal front wheel track necessary for majority of agricultural works (1550 mm for front wheels and 1600 mm for rear wheels) has been set at the factory. Front wheel track can be adjusted for different row-spacing or installation of front-lift by shifting retractable knuckles. Front wheel track width 7.5-20 and 9.0-20 varies from 1440 mm to 1740 mm with the step of 100 mm, and with wheel transposition – from 1500 to 1800 mm.

The operations for changing the front wheel track

1. Brake the tractor with the parking brake. Put the stops in front and behind the rear wheels.
2. Put the jack under one side of the front axle side. Lift the wheel until it takes off the ground.
3. Loosen the nuts of the coupling bolts (1), remove the pin (2) for fixing the retractable knuckle (3), loosen the tightening of the nuts (4) at the ends of steering rod tube (5).
4. Detach the cylinder (8) from the holder (7).
5. Move the retractable knuckle (3) inside or outside the front axle body. At the same time, rotating the tube (5) to vary the steering rod length by the value corresponding to the track to be set.
6. Insert the fixation pin (2) of the retractable knuckle and tighten the bolt nuts (1).
7. Insert and fix pin (6) of the cylinder into the respective hole of the holder (7) (see the table).
8. Repeat the operations on the opposite side of the front axle.
9. Adjust the front wheel toe-in.
10. Tighten the nuts (4) of the steering rod tube.

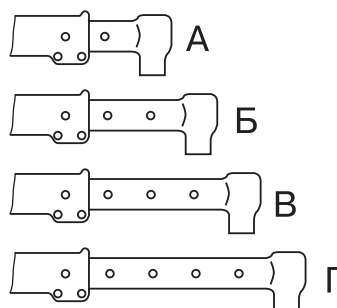
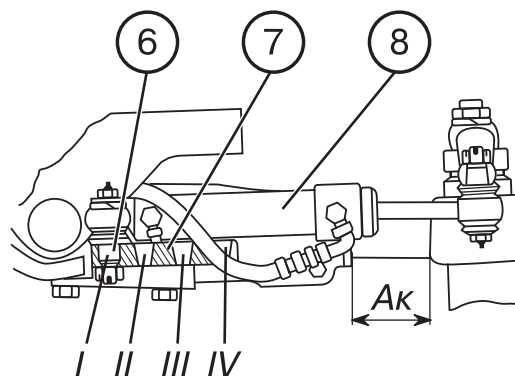
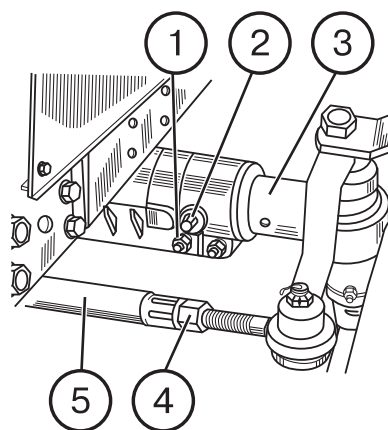

Wheel mounting scheme	Hole number			
	I	II	III	IV
	Size Ak			
	105	155	205	255
	Retractable knuckle position			
	A	Б	B	Г
	1440	1540	1640	1740
	1500	1600	1700	1800

Adjusting the front wheel track of the tractors with the FDA (Belarus 920/920.2/920.3/952/952.2/952.3)

I. FDA with bevel gear speed reducers; HPS with the cylinder in the steering trapezium

The track width of the tractor with the FDA can be adjusted (for the tyres of the basic scope of delivery of 13.6-20) within the range from 1430 mm to 1650 mm and with the wheel transposition – from 1770 to 1990 by extending the housings of the wheel reduction gears (with bevel gearings).

To adjust the track, proceed as follow:

1. Brake the tractor with the parking brake. Put the stops in front and behind the rear wheels.
2. Put the jack under one left side of the front driving axle. Lift the wheel until it takes off the ground.
3. Loosen the 4 bolts fixing the adjusting screw cover and remove the cover (2).
4. Turn out the two nuts (1) and remove the two wedges from the left side of the FDA.
5. Loosen the tightening of the nuts (3) at the ends of steering rod tube (4).
6. Remove the split pin and then the fixing pin (5) from the left side of the FDA. If the distance "H" exceeds 70 mm, refit the fixing finger (5) (position II).

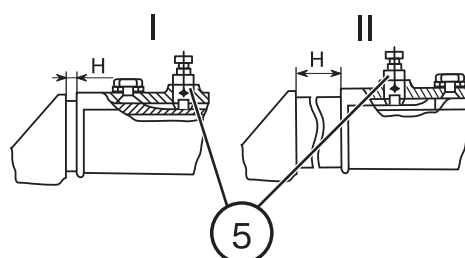
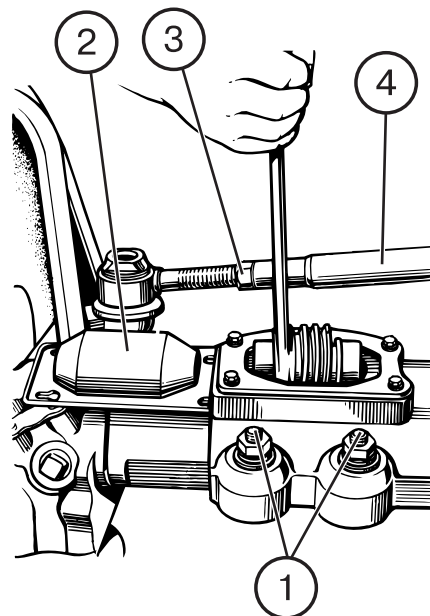

7. Detach the hydraulic cylinder (2) from the holder (1).
8. Move the wheel reducing gear housing by rotating the left adjusting screw using a wrench to obtain the required distance "A". At the same time, alter the steering rod length to the value corresponding to the track to be set by the rotating tube (4).
9. Install and fix the pin of the cylinder (2) into the hole of the holder (1) according to the Table above.
10. Insert and tighten the wedges and adjusting screw cover.
11. Repeat the operations on the right side. Set the size $A_R=A_L$.
12. Adjust front wheel toe-in (see recommendation below).
13. Tighten the nuts of the steering rod tube.
14. When transposing the wheels, tighten the disk fixing nuts to the flanges with the torque of 210...260 N·m. Then make sure that wheel rotation would coincide with the arrow on the tyre sidewall.

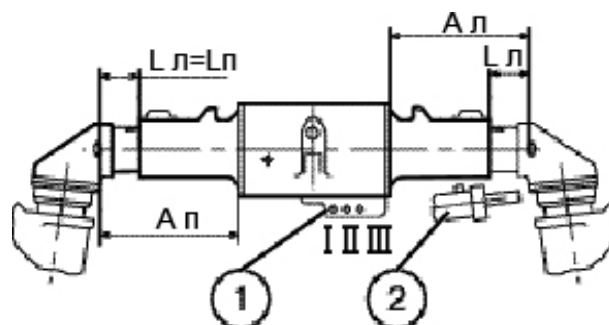

Wheel mounting scheme	Size of the wheel/tyre	Disk off-set, mm	Hole meter		
			I	II	III
			Size A		
			270	325	380
	W9x20/ 11,2-20	+80	1410	1520	1630
	W12x20/ 13,6-20	+70	1430	1540	1650
	W9x20/ 11,2-20	-90	1750	1860	1970
	W12x20/ 13,6-20	-80	1770	1880	1990

II. FDA with planetary reducing gears; HPS with the cylinder in the steering trapezium

Front wheel tractor track is adjusted within the range 1420 to 1970 mm by transposition of the wheels and mutual positioning of the wheel disks and rims.

To adjust the track, proceed as follow:

- Brake the tractor with the parking brake. Put the stops in front and behind the rear wheels;
- Lift the tractor front (or front wheels in turn) by means of a jack while keeping the clearance between the wheels and the ground;
- Remove the front wheels;
- Turn out the nuts fixing the rim to the disk.

Depending on the required track, set respective rim and disk arrangement as shown on the diagram.

When doing this, pay attention that wheel rotation would coincide with the direction of the arrow on the tyre sidewall.

When transposing the wheels, tighten the nuts fixing the disks to the flanges with the torque of 210...260 N m and those fixing the disks to the rims with the torque of 180...240 N m.

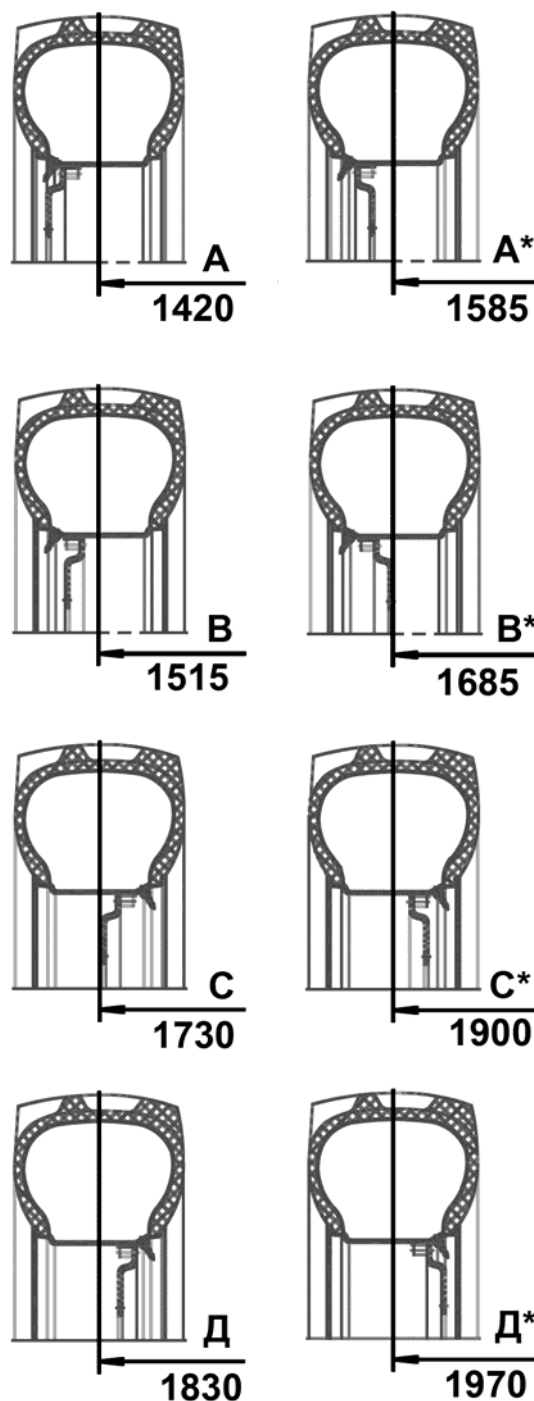

A, B, C, D – standard fitting of the disk with transposing the rim;
A*, B*, C*, D* – transposing the disk and rim.

The wheel position with transposing the disk (letters with asterisks) should be used in exclusive cases.

III. FDA with bevel reducing gears. Steering booster without the cylinder in the steering trapezium (if installed)

The front wheel track is adjusted steplessly by means of a screw mechanism located on the front axle cantilevers within the three intervals: 1350-1500 mm, 1500-1600 mm, 1600-1800 mm.

To obtain the required track width, set the appropriate positional relationship of the wheel rim relatively to the disk as shown in the figure below.

For the wheels with permanent disk offset, the track is adjusted steplessly within the range of 1400...1600 mm and 1750...1950 mm.

To alter the track, lift the tractor front (or front wheels in turns) while keeping the clearance between the wheels and the ground; brake rear wheels, after which:

- a) turn out the bolts (4) and remove the cover (2);
- b) release the cantilever wedges (3) having unscrewed the nuts so that the free movement of the bevel pair housings would be ensured.

The movement of the reducing gear housings in the front axle cantilevers with the wheels and obtaining of the required track within the specified intervals is provided by rotating the adjusting screw (1) with a wrench. The rotation of the adjusting screw shall be accompanied by steering rod length variation.

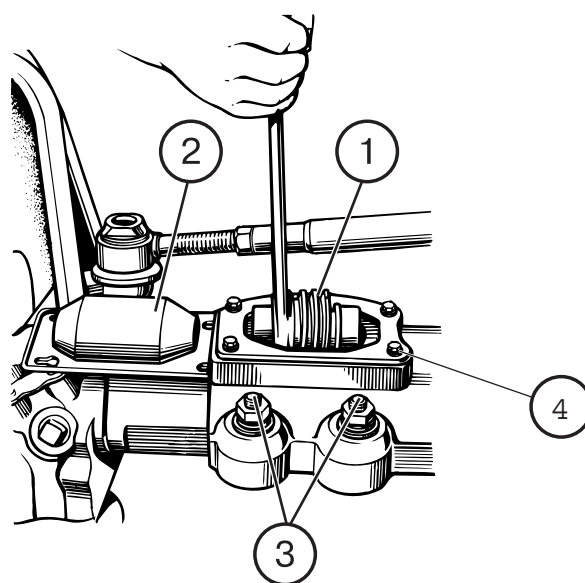

Adjusting the front wheel toe-in (tractors with the HPS)

Having changed front wheel track width, adjust the toe-in by altering steering rod length.

1. Inflate the tyres to the required pressure.
2. Drive the tractor forward on the flat ground to the distance of at least 3 m and stop it. Apply the parking brake.
3. Measure the distance "B" between two opposite points on the rim edge, behind FDA at the wheel axis height.
4. Drive the tractor forward so that the front wheels would turn by 180° and measure the distance "A" in front of FDA between the same points as when measuring the distance "B". The toe-in is set correctly when the value "A" is less than "B" by 0...8 mm. If toe-in does not correspond to these values, proceed as follows:
 5. Release the nuts (1) of the steering rod adjustment tube (2).
 6. Rotating the tube, set the required toe-in value.
 7. Tighten the nuts (1).

FDA with bevel reducing gears

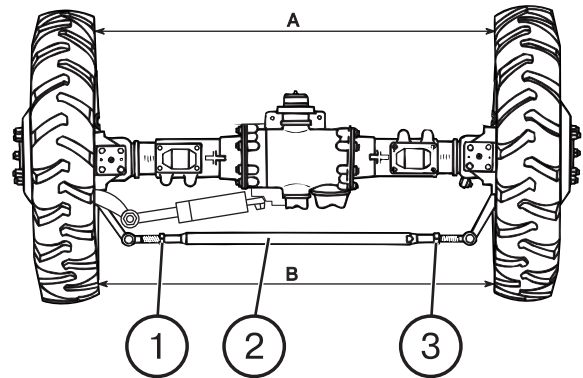

Front axle

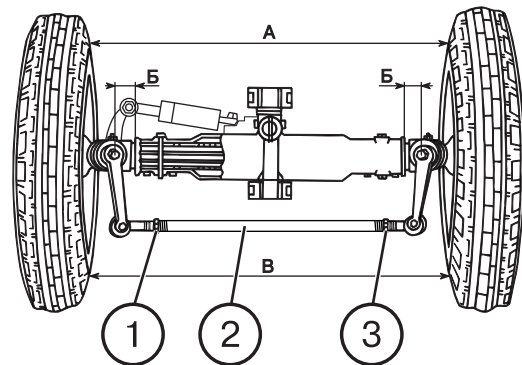

FDA with planetary cylindrical reducing gears

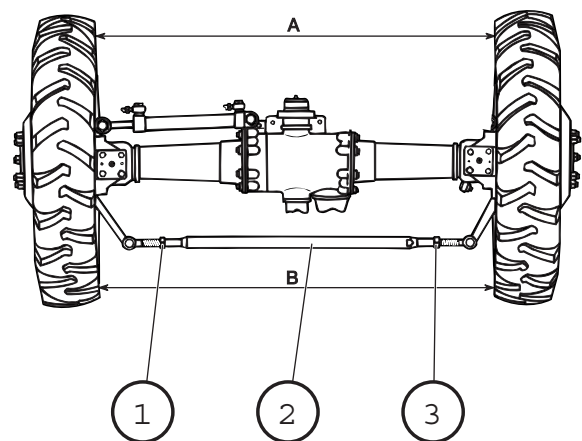

Adjusting the rear wheel track

1. Jack-lift the tractor rear part to separate the wheels from the ground.
2. Unscrew the wheel fastening nuts (1) and remove the wheels.
3. Loosen the four bolts (2) of the rear wheel hubs by 3...5 turns.
4. Move the hub in one or other direction to obtain the track width (use the table given below to determine the track width by measuring the distance "A" from the half-axle end to the hub face).
5. Tighten the four hub fixing bolts with the torque of 280-300 N m (28...30 kgf m).
6. Mount the wheel and tighten the nuts with the torque of 210-260 N m.
7. Repeat these operations on the opposite wheel.

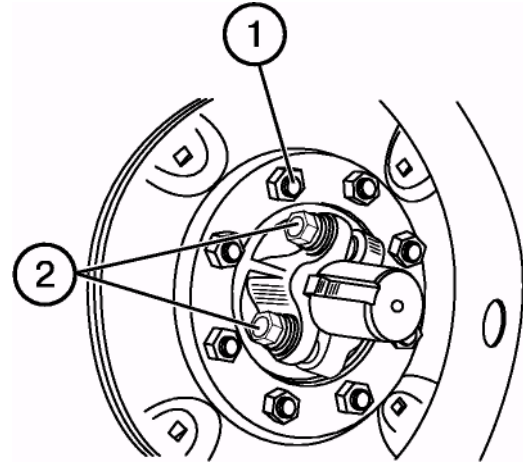

NOTE: Track width of up to 1600 mm can be obtained without changing the wheel disk position. To obtain the track width up to 2100 mm, transpose the rear wheels assembled with the hubs as shown in the figure.

Track width, mm	Distance "A", mm
1500	50
1600	0
1800	164
1900	114
2000	64
2100	14

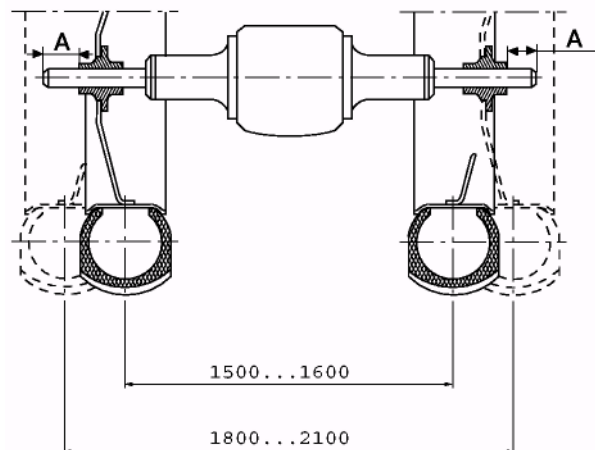

When transposing the rear wheels, pay attention that wheel rotation would coincide with the direction of the arrow on the tyre sidewall.

Adjusting the power takeoff shaft

External readjustment of PTO brake bands

During operation adjust PTO brake bands, if:

1. PTO slips.
2. When being repositioned, the PTO control lever rests against the front or rear part of the control panel slot.
3. When passing through the neutral position, there is neither click nor higher resistance.
4. The force to be applied to the control lever (1) exceeds 150 N (15 kgf).

Procedure of the external readjustment:

1. Put the arm (9) to the neutral position (the holes in the arm (9) and in the rear axle housing coincide), fix this position by means of a rod $\varnothing 8$ mm or a bolt M 10x60.
2. Remove the PTO enclosure together with the plate.
3. Turn out the bolt (17), take the lock bar (16) off the butt of the supplementary shaft (15) and turn the axle with the brake band clockwise using a wrench $8=13$ mm to take out the gap between the brake band and the drum (this will be clear by the impossible turning of the PTO shank by hand), then turn the axle counter-clockwise by $10-15^\circ$.
4. Mount the bar (16) and lock it with the bolt (17).
5. Remove the rod or bolt from the lever (9).

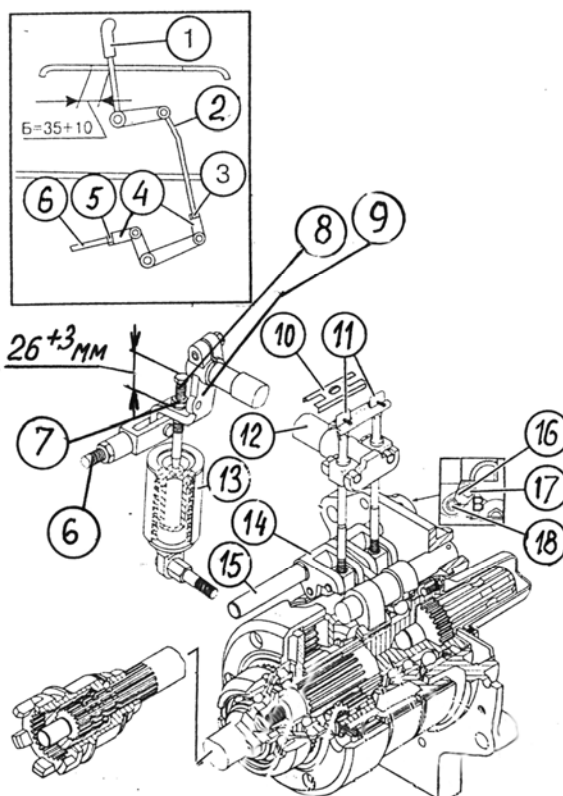

If the adjustment is made properly, the lever (1) in position "ON" will be at the distance of at least 35 mm from the control panel slot edge and will be neatly pass through neutral position (dead centre).

IMPORTANT! After several external readjustments, the eccentric shaft (15) can take the leftmost position (the flat is on the left vertically), which indicates the missing reserve of external adjustment. In this case, set the eccentric shaft to initial position by rotating it counter-clockwise (the flat is on the right vertically). Then make adjustments as described according to the section "Adjusting the control when repairing the PTO".

Adjusting the control when repairing the PTO

Put the eccentric shaft (15) to the right-most position (flat is on the right vertically) and lock it with a bar (16) and bolt (17).

1. Put the arm (9) to the "Neutral" position (holes in the arm (9) and rear axle housing coincide), fix this position using a rod $\varnothing 8$ mm or a bolt M 10x60.
2. Remove the cotter pin and lock bar (10), having released the screws (11) to make adjustment.
3. Tighten the adjusting screws (11) with the torque of 10 N·m (1 kgf·m) and then release them by 2-2.5 turns.
4. After adjustment, refit the lock bar (10) and cotter pins.
5. By adjusting the length of the rods (2) and (6) by means of the forks (4) and locknuts (3, 5), set the lever (1) to the middle position relatively to the control panel slot.
6. Turn the adjusting bolt (8) into the lever (9) to the dimension $A=26...28$ mm and fix it in this position by means of a locknut (7).
7. Remove a supplementary rod (or bolt M10x60) from the hole of the rear axle housing and the lever.
8. Check the correctness of performing the adjustment. When being moved, the lever (1) shall be clearly fixed in the extreme positions and in the "PTO ON" position the distance from the edge of the lever to that of the control panel slot shall be $35+10$ mm and the rods (2) and (6) shall not touch the nearby parts of the tractor during the motion.

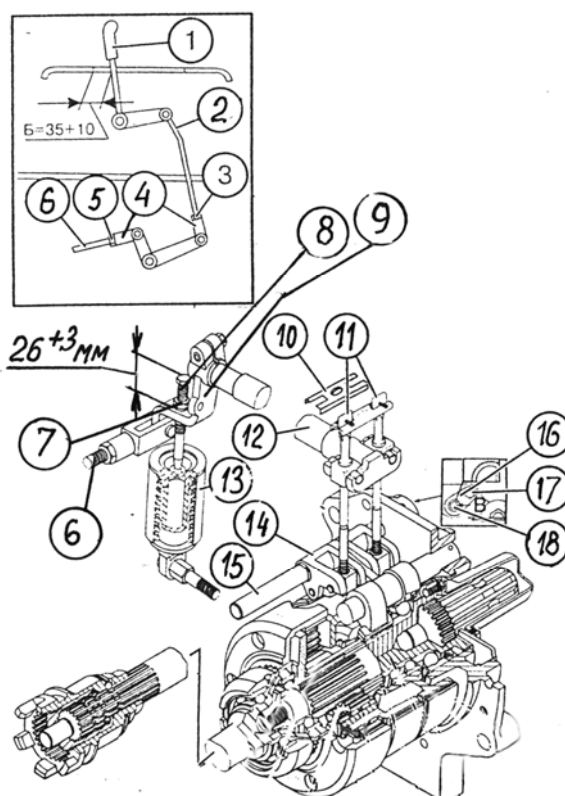

Adjusting control rod of FDA drive transfer box

To adjust the rod, proceed as follows:

- Put the lever (7) to position "PTO forcibly ON" (upper fixed position, catch ball (5) is in the lower indent "A" of the rod (4)).
- Turn out the locknut (3) by 2-3 turns, remove the cotter pin and then the pin (1).
- Turn the arm (11) clockwise until the full engagement of the transfer box (10), i.e. gear clutch is coupled with external and internal casings of the free travel coupling.
- Adjust the length of the rod (4) by rotating the fork (2) in such a way that the pin would enter freely the holes of the fork and arm (11) turned clockwise to the stop.
- Tighten the locknut, refit the pin and fix it with the cotter pin.

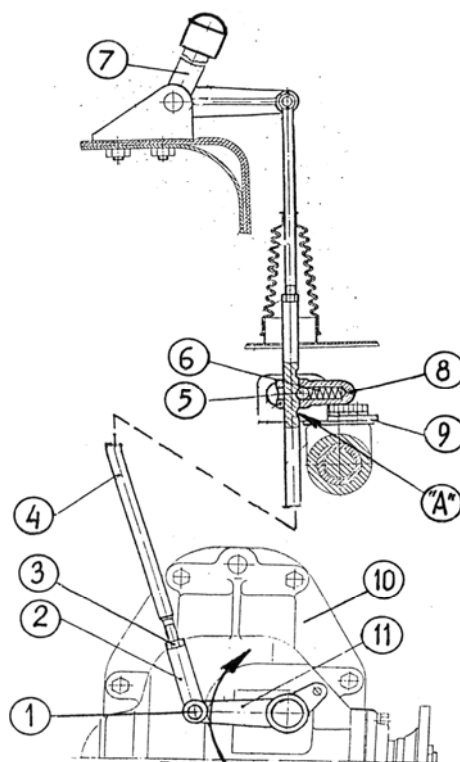

Adjusting the control of the power (position) governor

1. To adjust the control rod of the governor, proceed as follows:

Adjust the length of the rod (1) by means of the nuts (2) in such a way that a clearance of 18 to 24 mm would be formed between the rubber roller (5) and edge of the sector (4) when moving the lever (3) to the rearmost position with respect to the tractor motion.

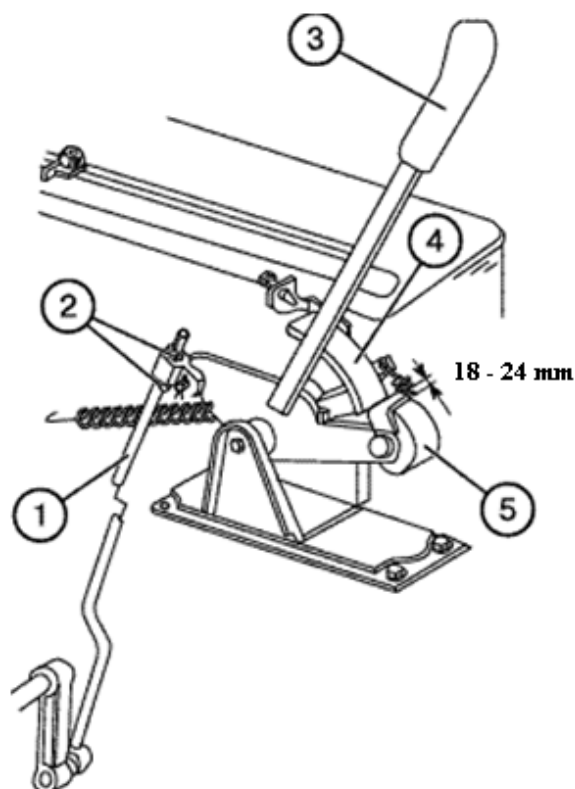

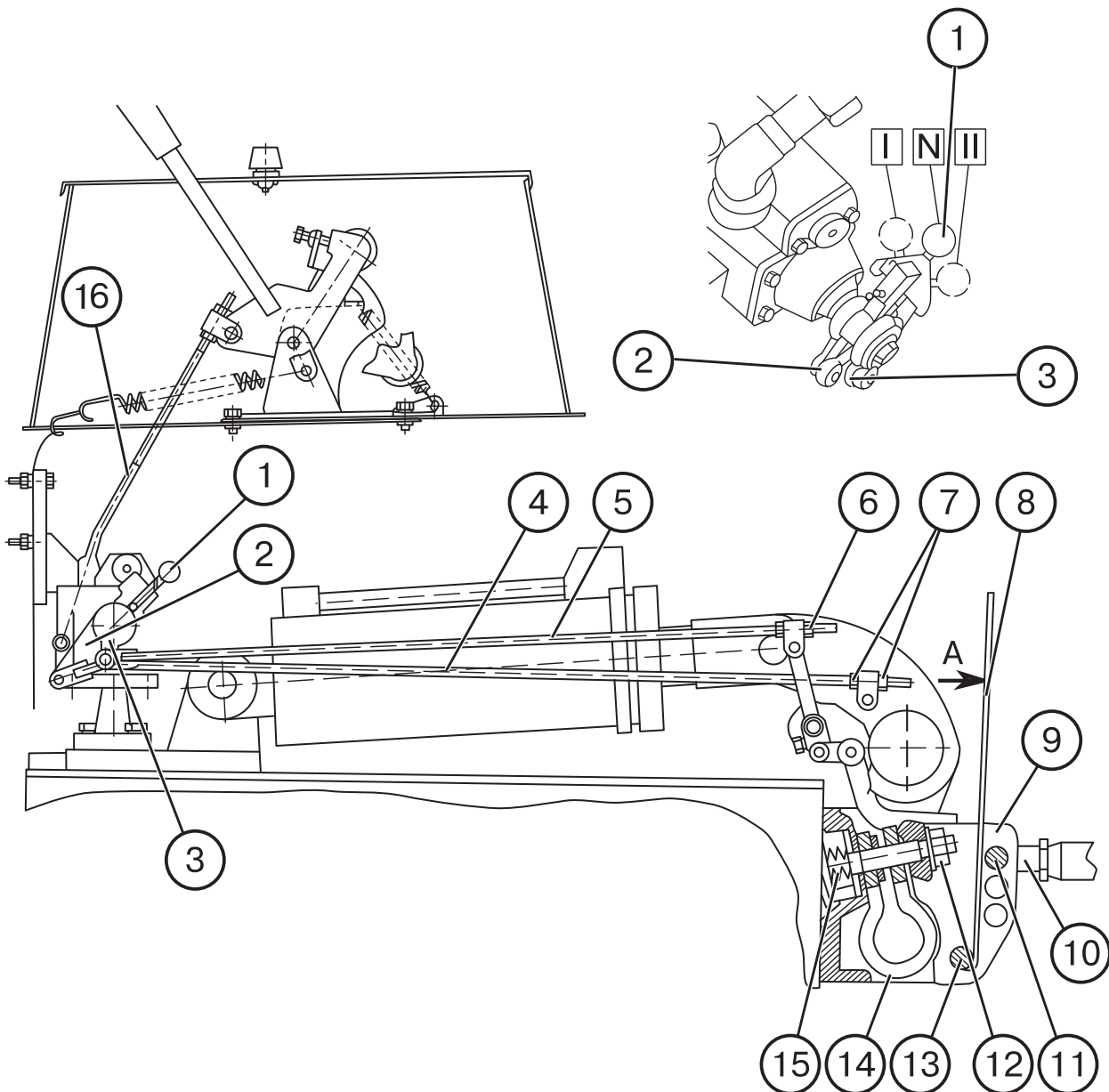

2. To adjust the position rod, proceed as follows:

- Set the switch (1) to the middle position;
- Lift the mounted attachment to the uppermost position;
- Adjust the length of the rod (4) so that the projection of the switch (1) would enter freely the slot of the position lever (2), then shorten the rod (4) by one turn of the adjusting nuts (7);

3. To adjust the power sensor, proceed as follows:

- Set the switch (1) to the middle position;

- Remove the central rod (10) of the mounted attachment and set the pin (11) of the central rod to the upper hole of the shackle (9);

c) Using an additional lever (8), turn the shackle around the pin (13) in the direction of the arrow "A" until the springs (15) are fully compressed. After removal of the load from the lever, the shackle shall return to the initial position; here the sensor travel measured by displacement of the power rod (5) shall be at least 11 mm;

- Having made sure that the sensor is in good order, remove the cotter pin from the castellated nut (12), turn it until the sensor springs begin to be compressed, then tighten it additionally by 1/2-1/3 turns until

the slot in the nut is aligned with the cutter pin hole and fix it by means of the cotter pin.

4. The power rod shall be adjusted after adjustment of the power sensor:

- a) Set the switch (1) to the middle position (see Fig. 28);
- b) Using an additional lever, apply a force ensuring the turn of the shackle to the extreme position (in the direction of the arrow "A");
- c) While holding the lever in the released position (in the direction of the arrow "A"), check the possibility of entering of the projection of the switch (1) to the slot of the power lever (3). If it is impossible, adjust the length of the rod (5) so that the projection of the switch (1) would enter freely the slot of the power lever (3);
- d) Shorten the rod (5) by 1 turn of the adjusting nuts (6).

With the agricultural implement mounted on the tractor no use of a special additional lever for adjusting the power rod is required. In this case, it is sufficient to lift slightly the implement above the surface of the ground, on which the tractor stays, then the weight of the implement would create a necessary stretching force applied to the power sensor through the central rod. It should be noted that the central rod shall be set to the upper hole of the shackle of the mounted attachment. The implement should be lifted just until it is taken off the ground.

Clutch adjustments

1. General

A dry single-plate spring-loaded clutch is mounted on the engine flywheel (1) (see Fig. a).

The driving part of the clutch consists of the flywheel (1) and pressure plate (3). The driven part of the clutch includes the driven plate (2) with the torsional vibration damper (8) mounted on the power shaft (6). The necessary force for pressing the friction surfaces of the driving and driven parts is provided by the nine main springs (21) and six additional springs (20), if the clutch is equipped with a driven plate 2 with ceramic-metal segments (Fig. b), no additional springs (20) are mounted in this case.

ATTENTION: To avoid the premature failure of the driven plate and parts of the transmission, follow the guidelines of this Manual: in case of installation of a driven plate with asbestos-free linings (Fig.a), the clutch plates are fitted with nine main springs 21 and six additional springs 20; in case of installation of a driven plate with ceramic-metal segments, the clutch plates are fitted with nine main springs 21 only.

The elastic components are placed between the floating bushing (7) connected with the PTO drive shaft (4) and the backing plate (10).

The clutch is engaged and disengaged by means of the shifter (16) with the release bearing (14) moving over the bracket (15). The shifter fork (17) with the roller (18) is connected with the clutch pedal by means of a rod.

The release bearing (14) is lubricated through a pressure lubricator screwed into the shifter journal.

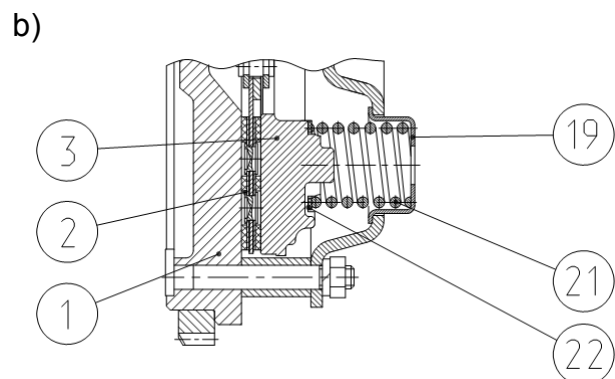
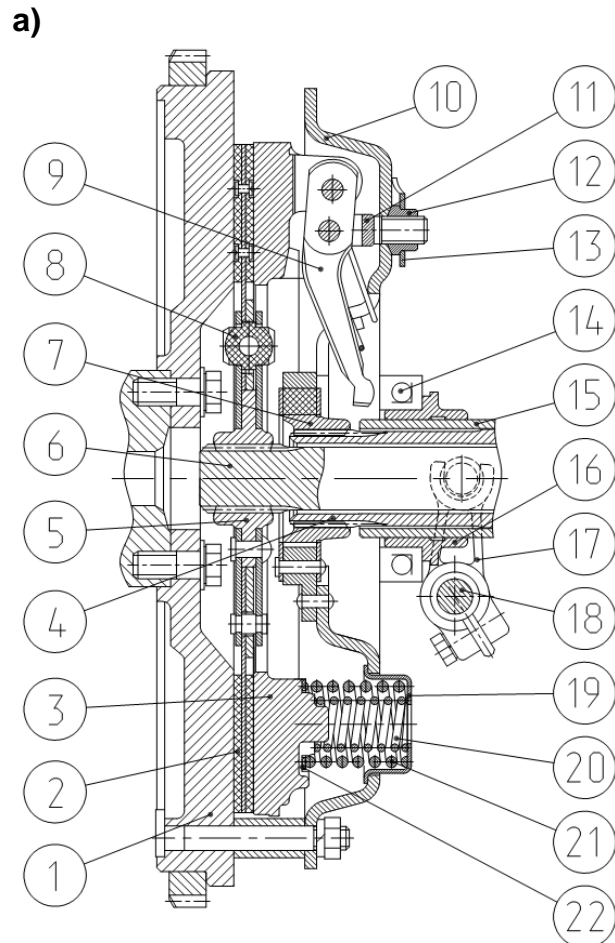

1 – flywheel; 2 – driven plate; 3 – pressure plate; 4 – PTO drive shaft; 5 – hub; 6 – power shaft; 7 – floating bushing; 8 – torsional vibration damper; 9 – clutch lever; 10 – backing plate; 11 – fork; 12 – nut; 13 – locking spring; 14 – bearing; 15 – shifter bracket; 16 – shifter; 17 – disengagement fork; 18 – control roller; 19 – sleeve; 20 – pressure spring; 21 – pressure spring; 22 – insulating washer.

Clutch

2. Procedure of removing the clutch from the engine:

1. Turn three auxiliary bolts (M12x40) into the pressure plate (3) through the auxiliary holes of the backing plate (6).

2. Turn out the nuts fastening the backing plate to the flywheel and remove the clutch plate assemblies (backing plate (6) with the pressure one (3)).

3. Remove the driven plate (2).

3. Procedure of replacing the clutch to the engine:

1. Place the driven plate (2) with the long end of the hub directed towards the flywheel (1).

2. Set the clutch plate assemblies (backing plate (6) with the pressure one (3)) onto the flywheel pins with the bushings (10) and fix them by means of the nuts (with the torque of 70...90 N·m).

3. Set the auxiliary mandrel and turn out the auxiliary bolts.

4. Adjust the position of the clutch levers (5).

4. Adjusting the position of the clutch levers

1. Adjust the position of the clutch levers to the dimension of 13 ± 0.5 from the bearing areas of the levers (5) to the end face of the hub (4) of the backing plate (6) by turning the adjusting nuts (8) on or off. The difference of the dimensions for individual levers shall not exceed 0.3 mm.

2. After adjusting the levers, set the lock plates (7) and fix them with bolts.

3. Remove the mandrel.

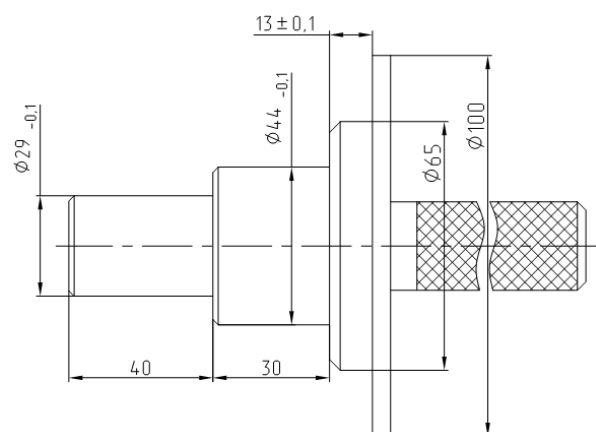
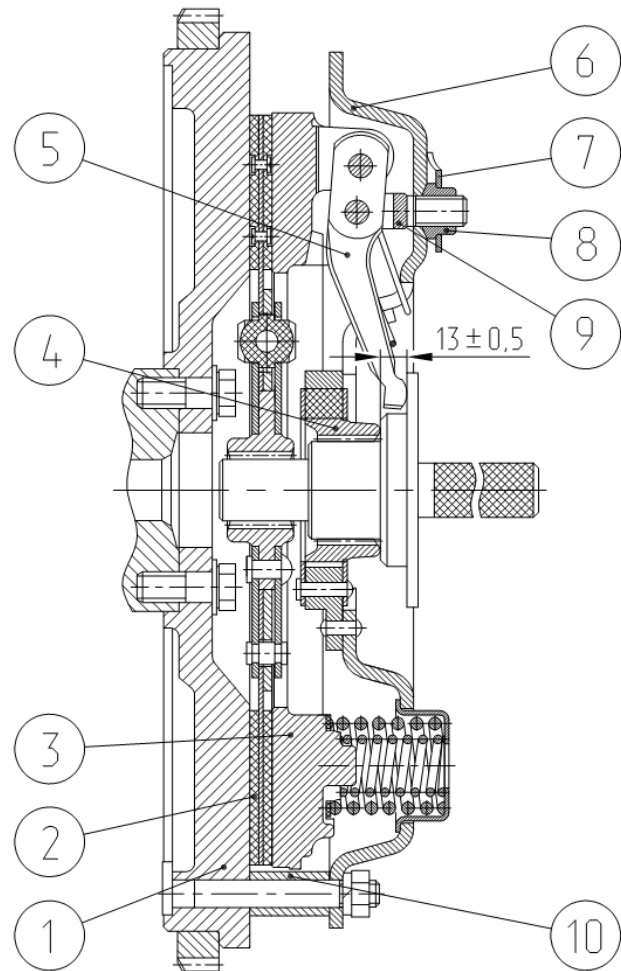

Auxiliary mandrel

Maintenance during the running-in:

- Check the level of and add, if necessary, oil into the crankcase and cooling fluid into the radiator;
- Drain condensate from the bottle of the pneumatic system;
- Monitor the soiling of the air cleaner against the pilot lamp;
- Check the working capacity of the engine, controls, lighting and signalling systems, the windscreen wiper and the brakes.

Maintenance on completion of the running-in (after 30 hours of operation of the tractor):

- Inspect and wash the tractor;
- Listen to the major parts of the tractor during operation;
- Check and adjust, if necessary, the tension of the fan belt, free travel of the clutch and brake pedals as well as the pneumatic system;
- Check the storage batteries and, if necessary, clean the batteries, terminals, wire lugs and vents in the plugs;
- Change oil in the engine crankcase, air cleaner tray, casings of power train, FDA and intermediate support;
- Grease the clutch shifter bearing;
- Service the dry-type air cleaner (Belarus-900.3/920.3/950.3/952.3);
- Replace the basis filtering element of the oil filter (Belarus-900.3/920.3/950.3/952.3);
- Clean the centrifugal oil filter (except for Belarus-900.3/920.3/950.3/952.3);
- Replace a filtering element of the hydraulic system;
- Flush a screen filter for pre-cleaning of engine oil;
- Check and tighten, if necessary, the external joints of the tractor components, including the bolts of the cylinder block head and the bolts fastening

- cardan shaft intermediate support holder to the transmission casing (for tractors with FDA), the bolts of power train casings, rear wheel hubs, rotary shaft holder and the nuts of the front and rear wheels;
- Check and adjust the clearances between the valves and the rocker actuators;
- Check the cooling fluid level and, if necessary, add it to the radiator;
- Drain the deposit from the fuel coarse filter and condensate the from pneumatic system bottle;
- Check and restore, if necessary, the air tightness of the air cleaner and engine inlet pipelines;
- Check working capacity of the engine, controls and the windscreen wiper.

SCHEDULED MAINTENANCE TABLE

No.	Subject of maintenance	Check	Cleaning	Lubrica- tion	Re- place- ment	Adjust- ment	Drain	Flushing	Remarks
Shift-time maintenance (STM) after each 10 hours of operation									
1	Oil in the engine	+							
2	Cooling fluid	+							
3	Oil in the hydraulic system tank	+							
4	Condensate in the pneumatic system bottle		+						
4a	Oil level in the HPS tank	+							
4b ¹⁾	Fastening the air-conditioner hoses	+							
4c ¹⁾	Air-conditioner condenser	+	+						
4d ¹⁾	Drain tubes of the air-conditioner	+	+						
4e ²⁾	Condensate in the CAC radiator tanks (Belarus-900.3/920.3/950.3/952.3)		+						
Maintenance No.1 (M-1) after 125 hours of operation									
5	Oil in air cleaner tray	+							
5a	Dry type air cleaner	+	+						
5b ¹⁾	Tension of the of the air-conditioner compressor drive belt	+				+			
6	Oil in the casing of (each) upper bevel pair	+							
7	Deposit of fuel coarse filter and fuel tanks							+	
8	Fan belt	+				+			
9	Hub and wheel fastening	+				+			
10	Air pressure in the tyres	+				+			
11	Cab ventilation system filter		+						
12	Clutch shifter bearing			+					
13	Storage batteries	+				+			
14	Oil level in the FDA cardan drive intermediate support	+							
15 ³⁾	Turbocharger (Belarus-900.3/920.3/950/950.3/952/952.2/952.3)	+							
16	Steering trapezium hydraulic cylinder joints			+					
17	Pin axle bearings of FDA wheel reducing gears (920.2/920.3/952.2/952.3)			+					
18 ³⁾	Play in steering rod joints	+				+			
19 ³⁾	Clutch pedal free travel	+				+			
19a ³⁾	Engine oil filter (basis filtering element)				+				

Continuation of the Table

No.	Subject of maintenance	Check	Cleaning	Lubrication	Replacement	Adjustment	Drain	Flushing	Remarks
Maintenance No.2 (M-2) after 500 hours of operation									
20	Rotor of the centrifugal oil filter of the engine		+						
21 ⁴⁾	Oil in the engine				+				
22	Clearances in engine valves	+				+			
23	Backlash of steering wheel	+				+			
24	Brakes (service and parking)	+				+			
25	Check the tightening of the bolts of the clamps of the CAC ducts (Belarus-900.3/920.3/950.3/952.3)	+							
26	Pneumatic system	+							
27	PTO control nit	+				+			
28 ³⁾	Front wheels (toe-in)	+				+			
30	Front axle steering knuckles (Belarus-900/900.3/950/950.3)			+					
31	Engine air cleaner		+						
32 ⁵⁾	Hydraulic system filter				+				
32a ⁵⁾	Filter of the HPS oil tank				+				
33	Alternator		+						
34	Deposit of fuel fine filter						+		
35	Transmission oil	+							
35a	Oil in the casings of "wet"-type brakes (if provided)	+							
36	Oil in the FDA casings and intermediate support	+							
37	Bearings of the FDA pivot bolts with planetary reducing gears	+				+			
37a ⁶⁾	Drying filter				+				
Maintenance No. 3 (M-3) after each 1000 hours of operation									
38	Bolts fastening the cylinder bock head	+				+			
39	Fuel coarse filter								+
40	Filtering element of fuel fine filter				+				
41	Alternator	+							

End of the Table

No.	Subject of maintenance	Check	Cleaning	Lubrication	Replacement	Adjustment	Drain	Flushing	Remarks
Maintenance after each 2000 hours of operation									
42	Front wheel bearings (Belarus-900/900.3/950/950.3)	+				+			
43	Steering rod joints	+				+			
44	Angle brace of the mounted attachment mechanism			+					
45	Shaft bushing of the mounted attachment mechanism			+					
46	External bolt joint of the tractor	+							
47	Oil in the hydraulic system tank				+				
47a	Oil in the HPS tank				+				
48	Transmission oil				+				
48a	Oil in the casings of the "wet"-type brakes (if provided)				+				
49	Oil in the FDA casings and intermediate support				+				
50	Flange bearings of FDA planetary reducing gears	+				+			
51	Engine oil primary filter		+					+	
52	Engine breather							+	
53	Engine injectors	+				+			
54	Fuel pump. Injection lead angle	+				+			
55	Fuel pump. Adjustment at the test bench	+				+			
56	Diesel engine cooling system		+					+	
57	Starter	+							
General maintenance									
58	Valve of centrifugal oil filter	+							

1) If the air-conditioner is provided.

2) In winter, the action shall be performed after each 10 hours of operation and in summer – after each 125 hours of operation.

3) The action should be performed after each 250 hours of operation.

4) For turbocharged diesel engines, change oil after each 250 hours of operation. In case of use the summer diesel fuel with the sulphur content of 1%, the intervals of change of oil in the engine crankcase should be halved.

5) The first change shall be performed after 500 hours, the subsequent ones – after each 1000 hours of operation as well as when performing the seasonal maintenance.

6) After each 800 hours of operation or once a year.

Shift-time maintenance (STM) after each 10 hours of operation or daily

Action 1. Oil level in the diesel engine crankcase

Stop the engine, wait for 15 minutes and check the oil level. The oil level shall be between the upper and lower marks of the probe (3). If necessary, take the cover (2) of oil filler neck (1) away and fill oil up to upper mark of the probe (3).

IMPORTANT! Do not operate the diesel engine with oil below the lower mark of the oil meter.

IMPORTANT! Do not fill up oil above upper probe mark. Excessive oil will burn, giving the false impression of high oil consumption for burning.

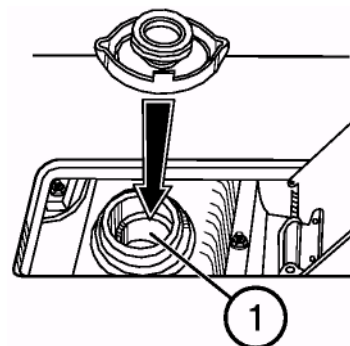
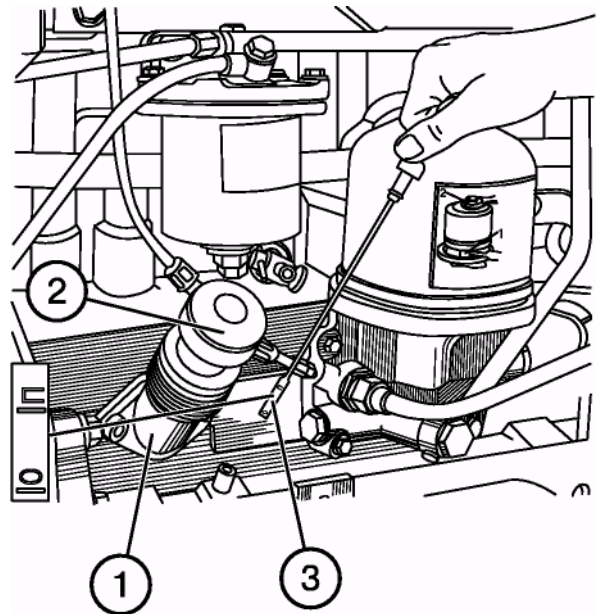

Action 2. Cooling fluid level in the engine radiator

Remove the radiator cap away and check the cooling fluid level, which shall be below the upper edge of the filler neck (1) by 50-60 mm. If necessary, add the cooling fluid to the level.

IMPORTANT! Do not allow the level to drop below 100 mm from the filler neck upper edge.

WARNING! The engine cooling system operates under pressure, which is maintained by the valve in the radiator cap. It is dangerous to take the cap away from the hot engine. Let the engine cool down, put some thick cloth on the cap and turn it slowly to reduce the pressure before removing the plug fully. Beware of burns caused by hot liquid!

Action 3. Checking the oil level in the hydraulic system tank

NOTE: Prior to checking the oil level, place the tractor on a flat horizontal area. Shut down the engine and engage the parking brake.

Check the oil level against the oil gage (1) on the left side of the hydraulic system tank. The level shall be between the marks "O" and "П" (Full). If necessary, fill up oil to the mark "П", having taken the rubber plug (2) away.

NOTE: When using the machines requiring large amount of oil taking, add oil to the level corresponding to the upper mark "C". When doing this, the hydraulic cylinders shall be with plungers indrawn.

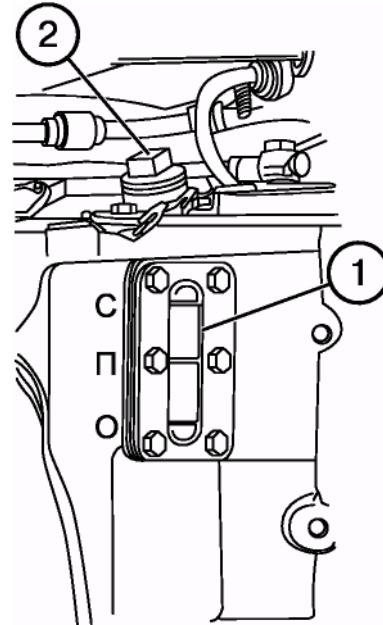

Action 4. Draining the condensate from the pneumatic system bottle

To remove the condensate from the pneumatic system bottle, pull the ring (1) of the drain valve horizontally and down.

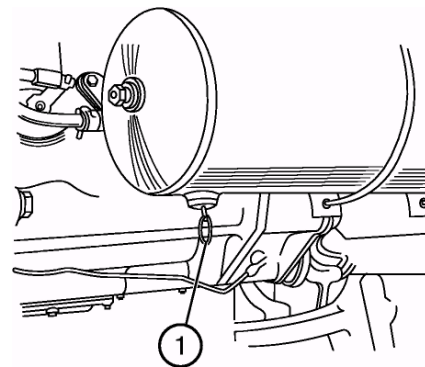

Action 4a. Checking the oil level in the hydrostatic power steering (HPS) tank (Belarus-900.3/920.3/950.3/952.3)

Prior to checking the oil level, place the tractor on a flat horizontal area. Shut down the engine.

NOTE: To get access to the HPS tank, lift the engine facing upwards to the stop and fix it reliably in lifted position.

Check oil level in HPS oil tank against oil-measuring rod (1). The oil level shall be between the upper and lower marks of the rod. If necessary, take the cap (2) of the filler neck away and add oil to the upper mark on the oil-measuring rod.

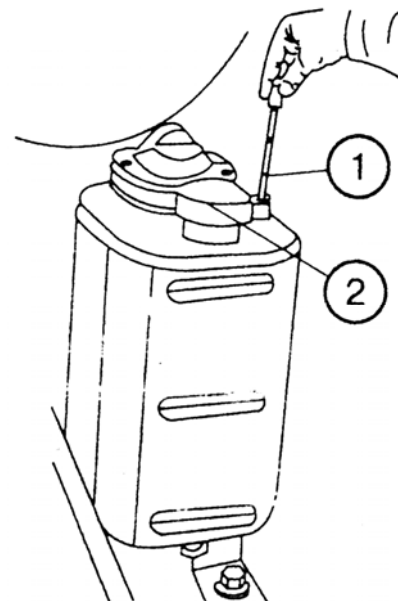

Action 4b*. Checking the fastening of the air-conditioner hoses

The air-conditioner shall be fixed reliably by means of the binding screw clamp. The contact of the hoses with the tractor's moving parts is not allowed.

Action 4B. Checking/cleaning of the air-conditioner condenser

Check the cleanness of the condenser core. If it is clogged, clean the condenser using compressed air. When the bonnet is open, direct the air flow at the right angle to the condenser plane top-down. Any crushed ribbing shall be rectified by means of a special comb or plastic (wooden) plate. In case of heavy dirtying of the condenser, flush it with hot water under the pressure of not more than 0.15-0.2 MPa and blow it off with compressed air.

Action 4d. Checking the drain tubes/cleaning them from condensate

The blue-coloured drain tubes are located to the right and left from the radiator tube under the ceiling panel. Check the drain tubes and clean them to avoid their clogging. The sign of a clean drain tube consists in water dripping during the operation of the air-conditioner in hot weather

Action 4d**. Removal of condensate from the engine radiator tanks (CAC) (Belarus-900.3/920.3/950.3/952.3)

To remove condensate from the engine CAC radiator tanks, proceed as follows:

- Turn out the two plugs 1 in the bottom portion of the charge air cooler (2) and let the condensate to drain;
- Turn in the plugs (1).

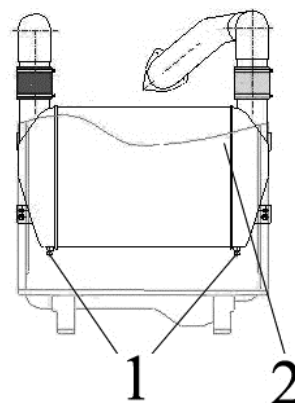

* In the air-conditioner is provided.

** In winter, the action shall be performed after each 10 hours of operation, in summer – after each 125 hours of operation.

Maintenance No. 1 (M-1) after each 125 hours of operation

Perform the previous actions plus as follows:

Action 5. Oil level and condition in the engine air cleaner tray (except for Belarus-900.3/920.3/950.3/952.3)

Loosen the two nuts (1) and remove the tray (2) of the air cleaner (3). Check the oil level in the tray, which shall be at the level of the ring collar "A".

Add oil, if necessary. If water is contaminated with dirt or in oil, replace it.

ATTENTION! Do not overfill the tray with oil above the ring collar "A", since it can result in oil ingress into the engine combustion chambers and development of false impression about increased oil consumption for burning.

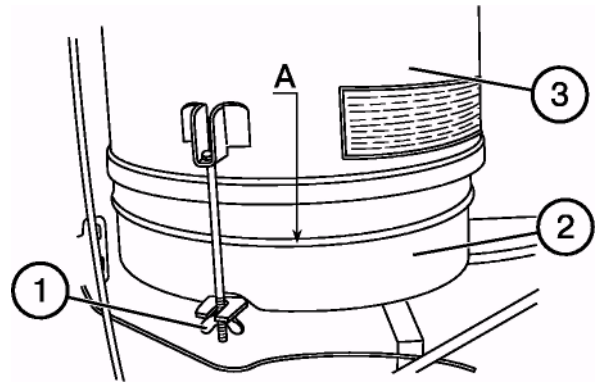

Action 5a. Servicing the air cleaner (Belarus-900.3/920.3/950.3/952.3)

The clogging of the air cleaner filtering elements is monitored by using a soiling indicator. In case of increased clogging, a signalling lamp lights up on the pilot lamp block of the dashboard.

After running-in the tractor (30 hours of operation) and after each 125 hours of operation, service the air cleaner. To do this, perform the following procedures:

- Remove the right side grid from the front part and facing to get access to the air cleaner;
- Pull the latch (1) (yellow), turn cover (2) counter-clockwise by 12.5° and remove it;
- Remove the major filtering element (3) (MFE);

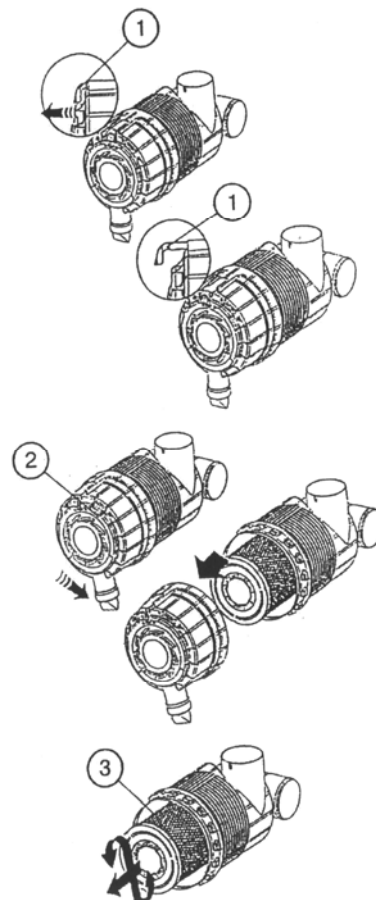

- Check the presence of clogging the filtering element (RFE) without removing it from the casing.

ATTENTION! It is not recommended to take the RFE from the casing.

The RFE clogging indicates the damage of MFE (breaking of paper blind, disconnection of the bottom). In this case flush RFE and replace MFE.

- Blow the major filtering element with compressed air first from inside and then from outside to completely remove the dust. To prevent the paper blind from rupture, the air pressure shall be max 0.2-0.3 MPa (2-3 kgf/cm²).

The air jet should be directed at an angle to the filtering element surface. When

servicing, protect the filtering element against mechanical damages and oiling.

When the filtering element is oiled or clogged so that the blowing with compressed air is ineffective, it should be replaced.

- To reassemble the air cleaner, proceed in the reverse order.
- Refit the right facing grid.

ATTENTION! Having reassembled the air cleaner, check air tightness of all joints of the inlet line; to do this, start the engine and shut down air intake at a medium speed of the crank shaft. When it will be done, the engine shall stop quickly. Otherwise, detect and eliminate looseness.

NOTE:.

Action 5a. Checking/adjustment of the tension of the air-conditioner compressor driving belt

The tension of the air-conditioner compressor driving belt (1) is considered to be normal, if deflection of its section "engine crankshaft pulley – compressor pulley" measured in the middle is within 4...6 mm under application of the force of $(39 + 2,0)$ N in perpendicular to the middle of the section.

The tension of the belt (1) shall be adjusted by rotating the compressor (2) on the rotation shaft (A) and clamp of the threaded connection (B) in the slot of the sector (B). After adjustment, the belt deflection caused by the force of $(39 + 2.0)$ N applied in perpendicular to the middle of the section, shall be from 4 to 6 mm.

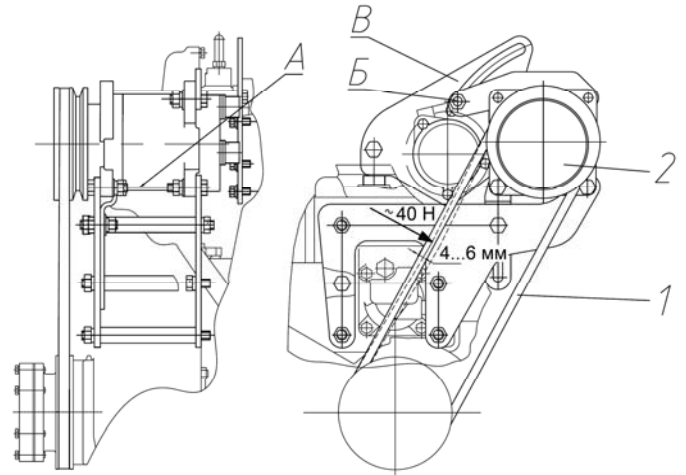

Action 6. Oil level in the casings of the upper bevel pairs of the FDA with the bevel reducing gears (Belarus-920/952)

Check that the oil level coincides with the lower edge of the oil-filling opening (1). If necessary, add oil.

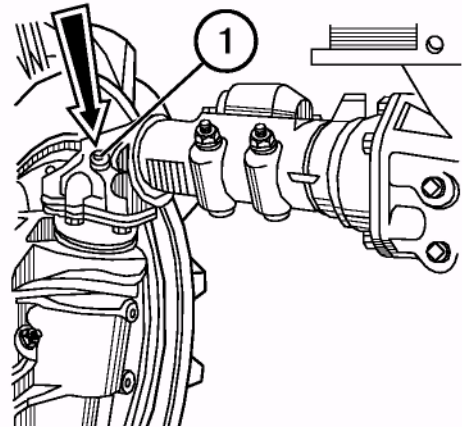

Action 7. Draining the deposit from the fuel tanks and fuel coarse filter

Open the drain plugs (1) of the fuel tanks (2) and the drain plug (3) of the filter and drain the deposit until clean fuel appears. Drain the deposit into a special tank and dispose it properly.

Close the drain valves after appearance of clean fuel without water and dirt.

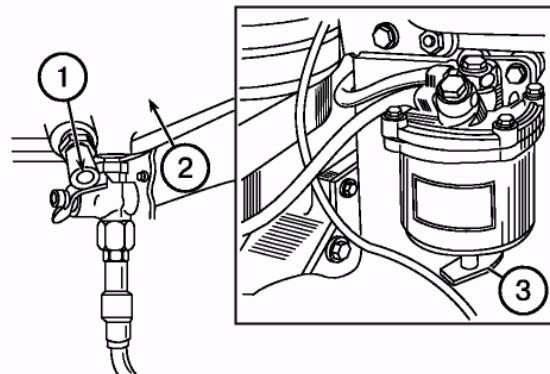

Action 8. Checking the tension of the belt for driving the engine cooling system fan

Check the belt for the presence of the traces of wear or damage. If necessary, replace it.

To check the tension of the belt of the engine alternator with an elongated shield, apply the force of 40 N at the middle of the belt section “alternator pulley – water pump pulley” (1). The deflection shall be within 6-10 mm. If necessary, adjust the belt tension by rotating the alternator body, having loosened the lath fixing bolt and the alternator fixing nuts, and then tighten them.

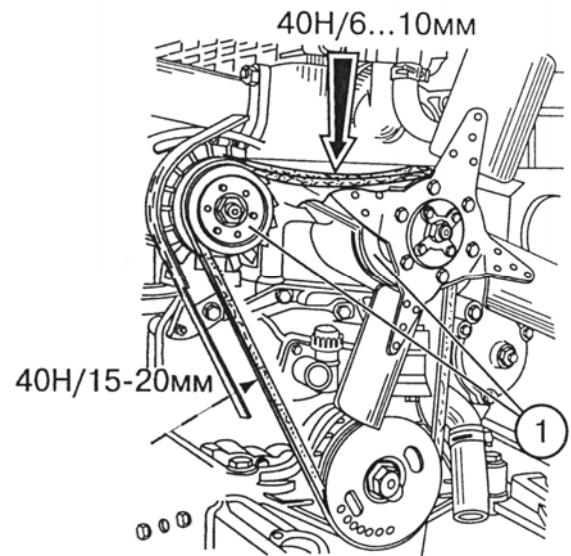

NOTE: When fitting a normal alternator shield, check the belt tension on the section “alternator pulley – crankshaft pulley”. The belt deflection shall be within the range 15...20 mm under the force of about 40 N applied to the middle of the section.

Action 9. Rear wheel hubs

Check the tightening torques and tighten them, if necessary, with the following torques:

- the bolts (1) of the rear wheel hubs: 360...500 N•m;
- the nuts for fastening the rear wheels to the hubs: 300...350 N•m;
- the nuts for fastening the front wheels to the flanges: 200...250 N•m;
- the nuts for fastening the disks of the front wheels to the rim supports: 180...240 N•m.

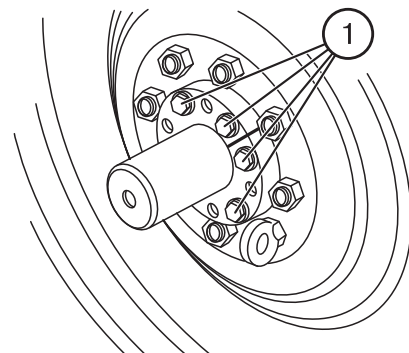

Action 10. Air pressure in the tyres

Check the tread condition and air pressure in the tyres. If necessary, adjust the pressure according to the recommendations given in the section “Operating Instructions”.

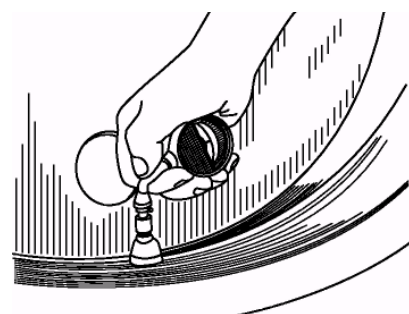

Action 11. Cleaning the filter of the cab heating and ventilation system

- Lift the cab roof (1).
- Unscrew the two fastening bolts and remove the filter cover (2) together with two filtering elements (3).
- Slightly shake up the elements to remove free dust particles from the filter. Be careful not to damage the filter.
- Clean the filters with compressed air under the pressure of not more than 2 kgf/cm² pressure. Keep the hose injector at the distance of minimum 300 mm from the filter so that not to damage basis filtering element. Direct the air flow through the filter against the normal air flow shown by the arrows on the filter.
- Fit the filter by performing the actions in the reverse order.

NOTE: Under humid conditions, e.g. early morning, do not switch the fan on before servicing the filter, since moisture particles got into the filter are difficult to remove.

NOTE: When operating the tractor under high dustiness conditions, clean the filter at shorter intervals.

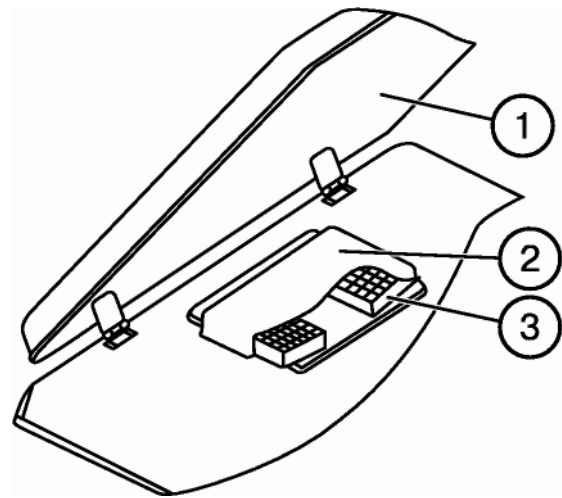

Action 12. Greasing the clutch shifter bearing

Remove the plug (1) from the left side of the clutch casing.

Insert the injector of the lever-plunger pressure gun into the opening and make 4-6 injections of the grease "Litol-24" through the oil feeder screwed into the shifter body to lubricate the release bearing.

NOTE: Do not inject excess grease, since it will be accumulated inside the clutch casing and can get on the friction surfaces of the driven disk friction facings.

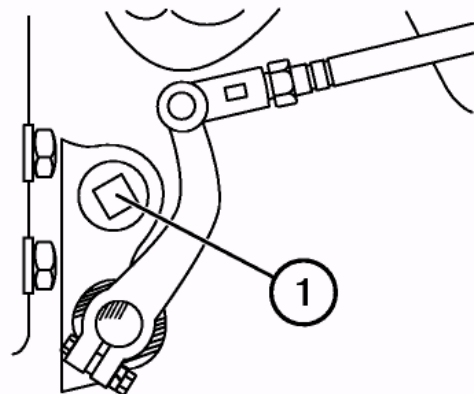

Action 13. Storage batteries

WARNING: Batteries contain sulphuric acid, which causes severe burns when getting onto open parts of the body. Beware of the acid getting onto the skin, into eyes and onto clothes. When the acid gets onto external body parts, wash them with plenty of pure water. In case of ingestion, drink plenty of water or milk. In case of contact with the mucous membrane of an eye, wash it with plenty of water for 15 minutes and then call for medical assistance. Do not allow spark of flame getting into electrolyte zone; this can result in explosion. Charge the batteries in a ventilated room. When servicing the batteries, put on protective goggles and gloves.

Keep the batteries dry and clean.

Make sure that the batteries are fixed reliably. Prior removing the plug, clean the adjacent surfaces.

Check the electrolyte level. It shall be above the protective mesh by 12-15 mm (or between the level marks on the battery transparent body).

Prior to adding distilled water, check the electrolyte density in each cell jar. If necessary, add distilled water.

Check that terminals (2) and plugs (1) are clean. If necessary grease the terminals with technical petroleum jelly and clean the vents in plugs (1).

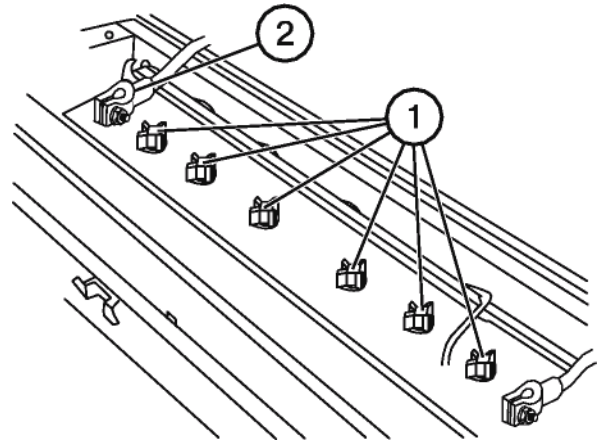

Action 14. Checking the oil level in the intermediate support of the FDA car-dan drive

Check the oil level in the intermediate support. If necessary, add oil to the level of the lower edge of the filler opening closed with plug (1).

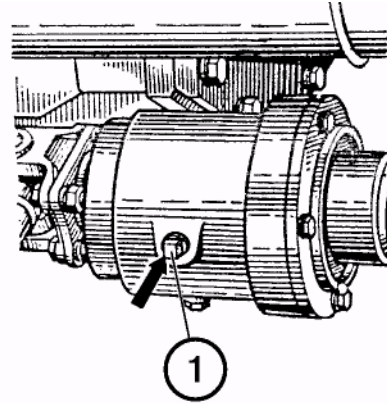

Action 15*. Turbocharger (Belarus-900.3/920.3/950/950.3/952/952.2/952.3)

Check the tightening of the fastening bolts of the turbocharger (1), exhaust manifold (2) and exhaust pipe holder (3). If necessary, tighten the bolts with the torque of 35-40 N-m (3.5-4.0 kgf-m).

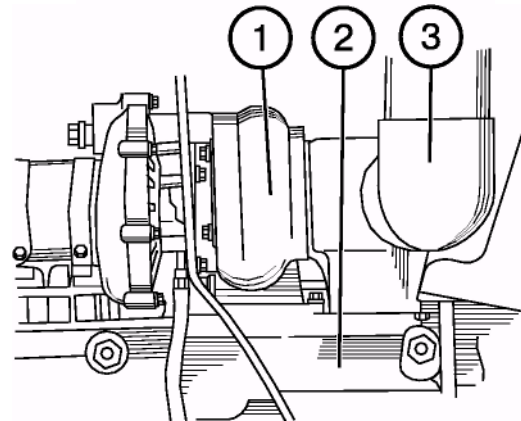

Action 16. Lubricating the hydraulic cylinder joints of the steering trapezium

Using a gun, grease the joints via oil feeders (1) (two off) with the grease "Litol-24" or recommended substitutes until it appears outside.

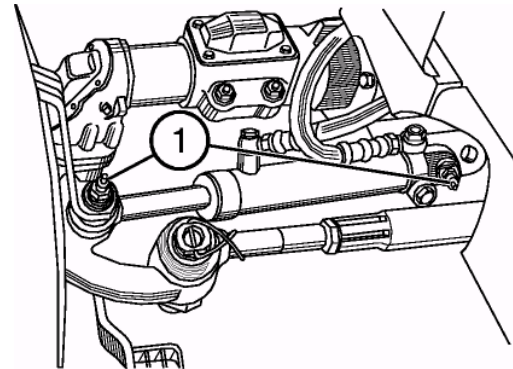

FDA with bevel reducing gears

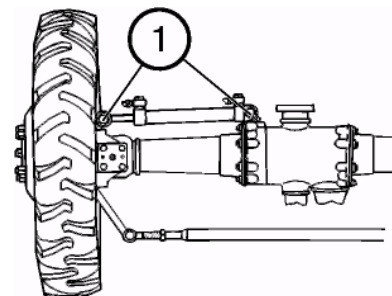

FDA with planetary reducing gears

* Perform M action after 250 hours of operation.

Action 17. Lubricating the bearings of the pivot axle of the FDA wheel reducing gears

(Belarus-920.2/920.3/952.2/952.3)

Lubricate the oil feeders of the upper and lower axles of wheel reducing gear pivot (4 lubrication points) with the grease "Litol-24" using a gun by making 4...6 injections.

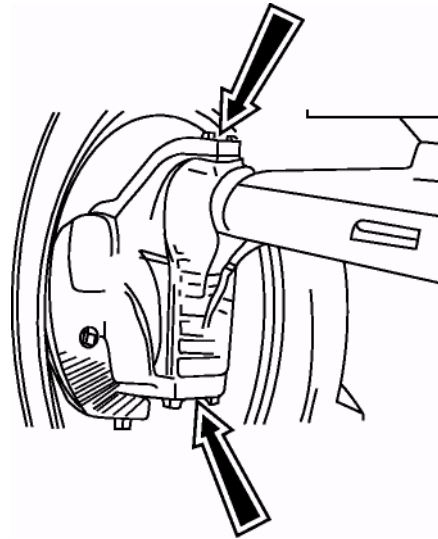

Action 18*. Checking the backlashes in the steering rod joints (Belarus-920/920.2/920.3/952/952.2/952.3)

When the engine is running, turn the steering wheel to both sides to check free wheeling and backlash in the joints (1) of the steering rod (4). In case of play in the joints, proceed as follows:

- remove the safety wire (3);
- tighten the treaded plug (2) to eliminate clearance in the rotary joint;
- lock the plug with wire (3)

NOTE: If tightening the threaded plugs does not eliminate the play in the joints, disassemble the joint and replace the worn-out parts.

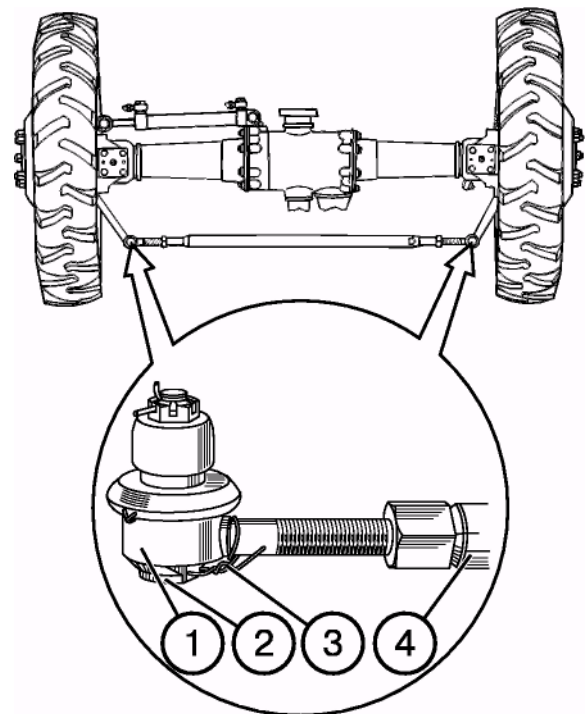

* Perform the M action after 250 hours of operation.

Action 19*. Adjusting the free travel of the clutch pedal

IMPORTANT! Too long pedal travel will not allow to the clutch to be fully disengaged and will make the gear switching difficult. Absence of free pedal travel will cause slipping of clutch disks, quick wear of friction facings and overheating of the clutch parts.

To adjust free clutch pedal travel:

- Unsplint and remove the pin (2) and take it away, having disconnected the rod (5) from the lever (1).
- Loosen the locknut (4).
- Unscrew the bolt (8) so that the pedal rod (6) would move upwards to the stop against the cab floor.
- Turn the lever (1) counter-clockwise to the stop, i.e. when the release bearing touches pressing arms.
- Unscrewing the fork (3), align the openings in the fork with those in the lever (1), and then screw the fork into the rod (5) by 5-5.5 turns (i.e. make the rod shorter). Connect the fork (3) with the lever (1) by using the pin (2).
- Assemble the leverage of the clutch pedal in reverse order.

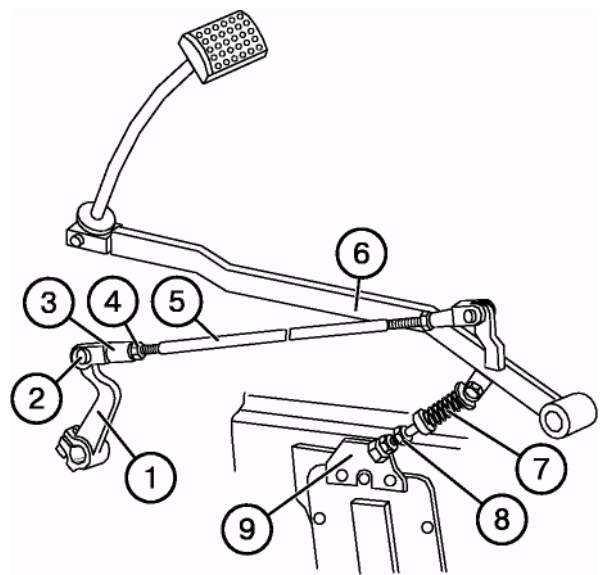

IMPORTANT! Make sure that the clutch pedal returns reliably to the stop against the floor at the distance of free pedal travel. Otherwise, adjust the servo-unit springs (7) by means of the bolt (8) or reposition the holder (9) by turning it relatively to the fastening bolt axis.

* Perform M action after 250 hours of operation.

Action 19a. Replacing the basis filtering element of engine oil filter

(Belarus-900.3/920.3/950.3/952.3)

After each 250 hours of operation, replace the paper filtering element (simultaneously with replacement of oil in the engine crankcase). To do this, proceed as follows:

- unscrew the prefabricated filter from the connecting branch (1) using a special wrench or other means and turn out the nut (3);
- remove the bottom (4) with the spacer (2) and ring (10);
- remove the valve (5), washer (6) and spring (7);
- press on the clamp (8), move it inside the cap (9) by 3-4 mm and turn it to align the clamp lugs with the cap outlet grooves;
- remove the clamp, paper filtering element, bypass valve (12) and spring (11) from the cap;
- wash the cap cavity and all the filter parts with diesel fuel;
- replace the filtering element, spacers (2) and (10) and anti-drain valve (5) and re-assemble the filter in the reverse order.

The torque for tightening the nut (3) – 30...40 N•m (3...4 kgf-m).

When mounting the prefabricated filter on the connecting branch, grease the rubber gasket (2) with motor oil and screw in the filter.

After touching the body by the gasket, turn the filter additionally by $\frac{3}{4}$ of a turn. Install the filter on the body with applying the force from the hand only.

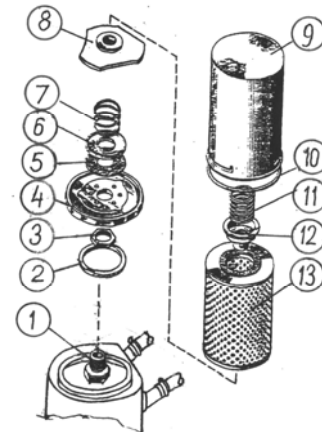
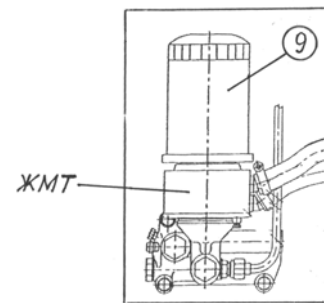

It is allowed to mount the non-separable filter cartridges with anti-drain and bypass valves instead of the prefabricated filter with removable paper filtering element. They have the following overall dimensions:

- diameter: 95...105 mm;
- height: 140...160 mm;
- pilot thread: 3/4" - 16UNF.

Maintenance No. 2 (M-2) after each 500 hours of operation

Perform the actions of the previous maintenance plus the followings:

Action 20. Centrifugal oil filter of the engine (except for Belarus-900.3/920.3/950.3/952.3)

- Turn out the nut (1) and remove the cap (2).
- Insert a screwdriver (5) or a rod between the filter body and the rotor bottom to lock the rotor (3) against rotation and remove the rotor barrel (3) by turning the rotor nut with spanner (4).
- Remove the cover (6), impeller (7) and filtering grid (8) of the rotor. If necessary, clean and flush the grid.
- Remove the deposits from the inner walls of the rotor barrel using a non-metallic scraper.
- Clean all the parts in a washing solution and blow with compressed air.
- Reassemble the filter by performing the same operations in the reverse order. Prior to assembling the barrel with the rotor casing, grease the seal ring with motor oil.
- Align the balancing marks of the barrel with those on the rotor casing. Tighten the barrel-fastening nut with a slight force until the barrel is fully set on the rotor.
- The rotor shall rotate freely, without jamming.
- Fit the cap (2) and tighten nut (1) with 35-50 N•m torque.

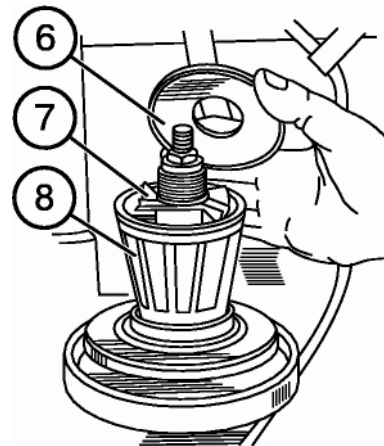
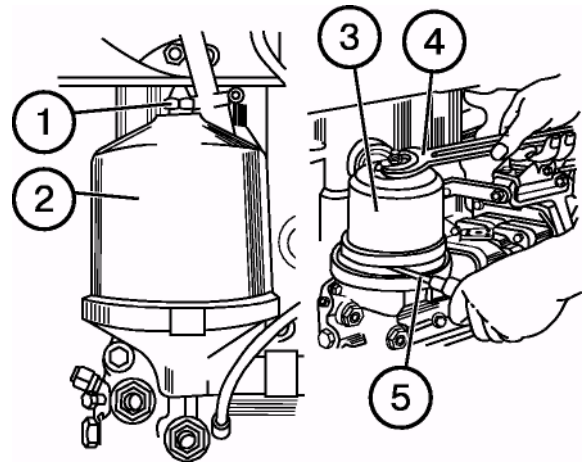

NOTE: After stopping the engine, the noise of the turning rotor shall be heard for 30-60 s. This indicates that the filter operates properly.

ATTENTION! For supercharged diesel engines, clean the centrifugal oil filter after each 250 hours of operation.

Action 21*. Changing the oil in the engine

- Warm up the diesel engine to normal operating temperature (at least 70°C).
- Place the tractor on a flat area, stop the engine and apply the parking brake.
- Remove the cap (2) of the oil filler neck and unscrew the drain plug (4).

ATTENTION: be careful to avoid contact with hot oil.

Drain oil into waste storage tank.

- Place the drain plug (4) back and fill in fresh motor oil through oil filler neck (1) (M-8ДМ, M-8Г₂, M-8Г_{2К} in winter and M-10ДМ, M-10Г₂, M-10Г_{2К} in summer to the upper mark of the oil-measuring probe (3)).
- Refit the filler neck cap (2).
- Start the engine and let it run for 1-2 minutes.
- After 10 minutes from the moment of stopping the engine, check oil level with the probe.
- If necessary, add oil.

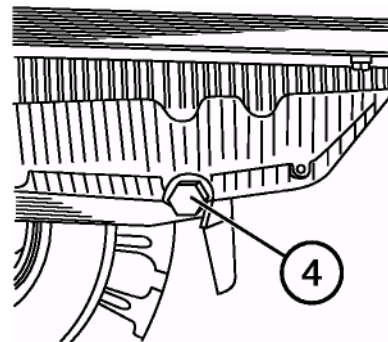
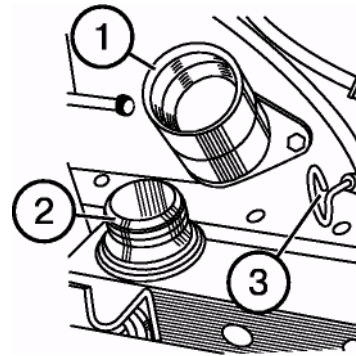

* For supercharged diesel engines, change oil after each 250 hours of operation.

Action 22. Checking the clearances between the valves and the rockers

NOTE: check the clearances on the cold engine, having verified preliminary the tightening of the cylinder head bolts.

To perform the adjustment, proceed as follows:

- Remove the cylinder head cover cap and check the fastening of the rocker axle rests. The nut tightening torque shall be 60-90 N•m (6-9 kgf•m);
- Rotate the engine crank shaft until the moment of closing of the valves of the 1st cylinder (intake valve starts opening, exhaust valve finishes closing) and adjust clearances in the 4th, 6th, 7th and 8th valves (counting from the fan);
- To adjust the clearance, loosen the locknut (1) of screw (2), insert the feeler (5) between the face of valve rod (3) and the rocker head (4) and set the required clearance against the feeler by turning in or out the screw (2).

The clearances between the rocker head and the valve rod face on the cold engine for intake and exhaust valves are given in the table below:

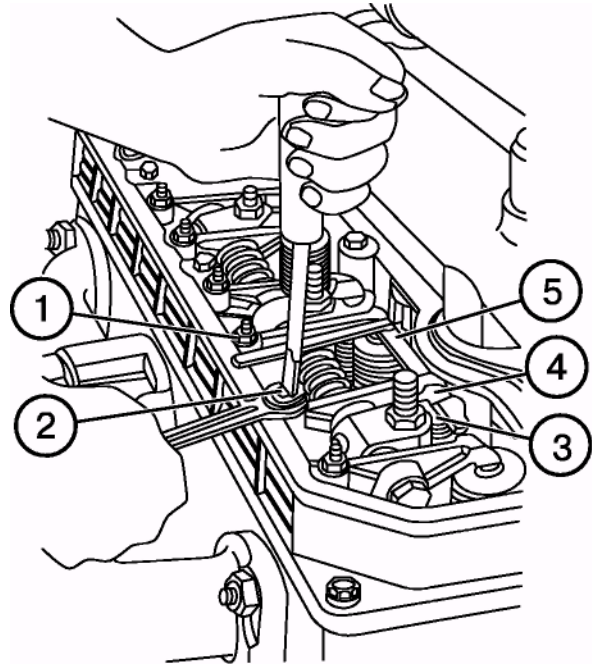

- Turn the crankshaft through 360°, set the valve closing at the 4th cylinder and adjust clearances in 1st, 2nd, 3rd and 5th valves as shown above;
- Having made the adjustment, tighten the locknuts (1) and refit the removed parts.

Belarus-900/920/920.2		Belarus-900.3/950/952/952.2//920.3/ 950.3/952.3	
Intake valves	Exhaust valves	Intake valves	Exhaust valves
0.20-0.35	0.20-0.35	0.20-0.35	0.35-0.50

Action 23. Steering wheel play

When engine is working, the steering wheel play shall not exceed 25° . If no so, check and eliminate the plays in the joints of the hydraulic cylinders and steering rod.

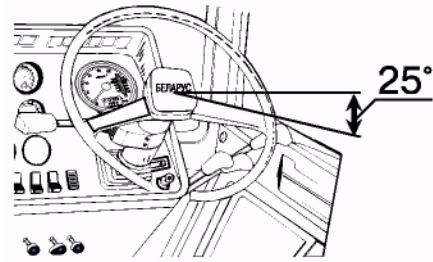
**Action 24. Adjusting the service and parking brakes. Aligning the brake valve and pneumatic system pressure regulator**

To adjust the brake control, proceed as follows;

- a) Unscrew the locknuts (3) of adjusting bolts (2);
- b) Screw the bolts (2) into the adjustment forks or unscrew them so that the full brake right pedal travel would be within 105-115 mm at the force of 120-130 N and braking distance of max 6.0 m at the speed of 20 km/h and force of 600 N on the pedals blocked with the bar (1) would be ensured, as well as non-simultaneous braking onset of max 1 m (against the impress) would be guaranteed. The travel of the left brake pedal shall be less by 5-20 mm to provide the simultaneous brake actuation in the blocked condition. Reduction of brake pedal travel below given above values is not allowed, since it leads to premature brake lining wear and brake overheating;
- c) Tighten the lock nuts (3). Ingress of grease into the brake causes the disk oiling and reduces the friction between their working surfaces (brakes do not hold). In this case, disassemble the brake, eliminate the oil leakage, wash the oiled disks with gasoline and let them dry within 5-8 minutes. After assembly, adjust the brake control.

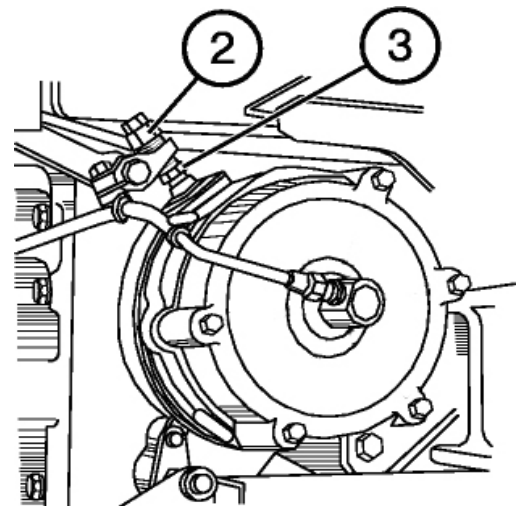
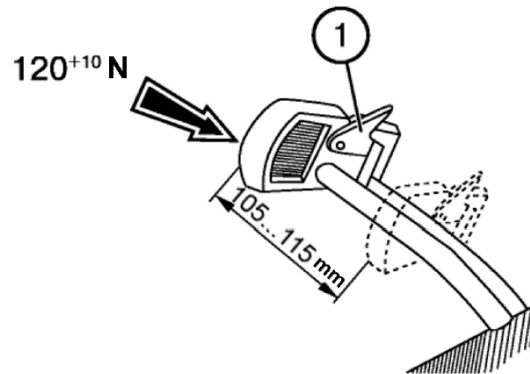

To adjust the parking brake, place the tractor on the flat area, stop the engine, lock the front wheels from the front and behind, and proceed as follows:

- Push the parking brake control lever (1) to the front position (from yourself);
- Loosen the tightening of adjusting bolt locknut (1) (see the lower figure below), as well as the locknut (7) and remove the pin (5);
- Turn the arm (4) and align the upper edge of the slot "B₁" of the arm (2) with the upper edge of the slot "B₂" of the arm (3) of the right brake pedal and then align the openings of the arm (4) with those of the fork (6) by rotating the fork (6) and then insert the pin (5);
- Turn the bolt (1) in or out so that when moving the control lever towards yourself with the force of 200^{+10}N , the latch would be retained in the dent between the third and the fourth teeth of sector "A", and the tractor would be held on 18% slope. After adjustment, tighten the loosened locknuts.

The final check and adjustment of the parking brake should be performed on the tractor assembled. The tractor shall be held motionless on the slope of at least 18% when applying the force of not more than 400 N to the parking brake control lever (1) (upper figure). If necessary, correct the adjustment using the adjusting bolt (1) (lower figure).

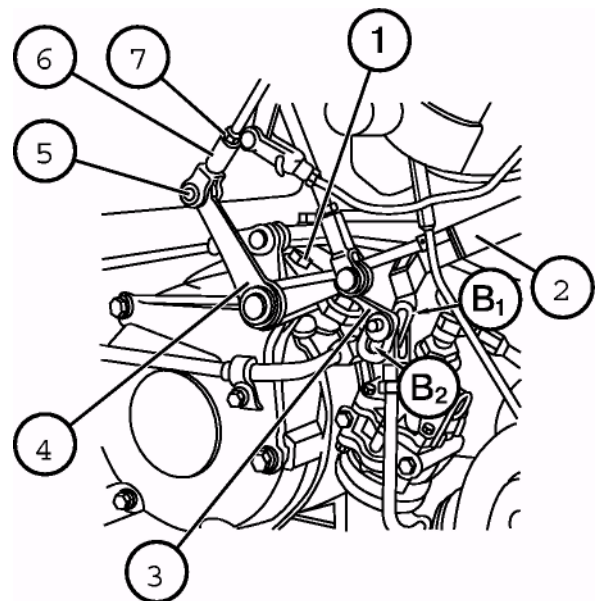
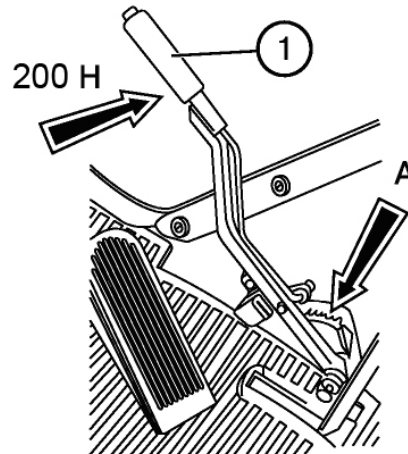

Note: For the tractors equipped (optionally) with multi-disk brakes operating in the oil bath, the steps of adjustment of the service and parking brakes are identical to those described above for tractors with dry-type brakes.

Checking and adjusting the pneumatic system brake valve and its actuator.

The pneumatic actuator of the trailer brakes is provided with a brake valve. For normal operation of the brake valve and brakes of trailers unitized with a tractor, check the brake valve operation and, if necessary, adjust it.

The adjustments shall be performed at a free position of the tractor brake controls after adjustment of the working and parking brakes.

For a single-line pneumatic actuator:

1. Attach a pressure gauge with the scale of at least 10 kgf/cm² to the connection head of the tractor pneumatic drive.
2. Turn the compressor on and pressurize the air bottle to the value of 7.7-8.0 kgf/cm² against air pressure indicator located on the tractor dashboard. The pressure gauge attached to the connection head shall display at least 7.7 kgf/cm². If it is below the given value, proceed as follows:
 - Check the presence of the gap "a" between the pin (5) and the upper edge of the slots of the levers (7 and 8). The gap shall be 1-2 mm;
 - If there is no gap, unsplint and remove the pin (5) and adjust the rod length by rotating the rod end (4).
3. Check and adjust, if necessary, the preliminary compression of the spring (3) to the size of 36-38 mm by rotating the nuts (2), after which lock the nuts.

The preliminary compression of the spring is adjusted so that when stepping on the service brake pedal or applying the parking brake, first the brake valve plunger would move to the stop and then the spring would be compressed.

4. If necessary, adjust the brake valve.

The pressure in the pneumatic line, i.e., pressure on the gauge attached to the connection head, is adjusted by rotating the nut located under a rubber boot (8).

To perform the adjustment, discon-

nect the rod (1) from the lug (9), remove the boot (8), unscrew the lug by 2-3 turns and adjust the air pressure to minimum 7.7 kgf/cm² (for Hungary and Germany – 5.3-6.0 kgf/cm²) by turning the nut. Screw the lug into the nut to the stop and lock it. Put on the boot and attach the rod.

If the brake valve actuator and the valve are adjusted properly, when moving the blocked brake pedals to the full travel or applying the parking brake to fixation at the 2nd or 4th tooth, the pressure as indicated by the pressure gauge attached to the connection head shall decrease to zero.

Disconnect the pressure gauge from the connection head.

For two-line pneumatic actuator (Belarus-900.3/920.3/950.3/952.3)

Attach a pressure gauge with the scale of at least 10 kgf/cm² to the connection head with the yellow cap of the control line.

Turn the compressor on and pressurize the air bottle to the value of 7.7-8.0 kgf/cm² against air pressure indicator located on the tractor dashboard. The pressure gauge attached to the connection head shall display 0 kgf/cm².

If the pressure exceeds the above value, proceed as follows:

- Check the presence of the gap "a" between the pin (5) and the upper edge of the slots of the levers (7 and 8). The gap shall be 1-2 mm;
- If there is no gap, unsplint and remove the pin (5) and adjust the rod length by rotating the rod end (4).

Check and adjust, if necessary, the preliminary compression of the spring (3) to the size of 36-38 mm by rotating the nuts (2), after which lock the nuts.

The preliminary compression of the spring shall be adjusted so that when stepping on the service brake pedal or applying the parking brake, first the brake valve plunger would move to the stop and then the spring would be compressed.

If necessary, adjust the brake valve.

To perform the adjustment, disconnect the rod (1) from the lug (9), remove the boot (8), unscrew the lug by 2-3 turns and adjust the air pressure to 0 kgf/cm² by turning the nut. Screw the lug into the nut to the stop and lock it. Put on the boot and attach the rod.

If the brake valve actuator and the valve are adjusted properly, when moving the blocked brake pedals to the full travel or applying the parking brake to fixation at the 2nd or 4th tooth, the pressure as indicated by the pressure gauge attached to the connection head shall increase to 6,5-8,0 kgf/cm².

Disconnect the pressure gauge from the connection head.

If the specified adjustment does not ensure said pressure parameters, take the

brake valve away and send it for repair.

IMPORTANT! When the brake valve actuator and the valve are adjusted properly, the pressure as indicated by the pressure gauge attached to the connection head in the single-line drive shall decrease to zero and in two-line drive shall increase to 6.5-8.0 kgf/cm² when stepping on the blocked pedals to the full travel as well as when applying the parking brake.

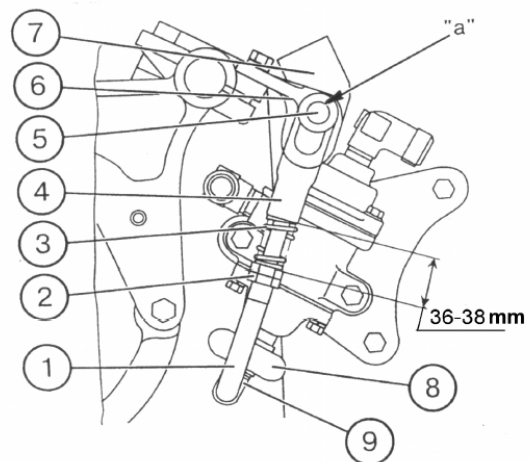

Checking and adjusting the pneumatic system pressure regulator

After 1000 hours of operation of the tractor (M-3), in case of malfunction of the pressure regulator, as well as after its disassembly for washing or replacement of worn-out parts, perform the adjusting operation as follows:

- Attach a pressure gauge with the resolution of 0.1-0.2 kgf/cm² and scale of at least 16 kgf/cm² to the bottle for the period of verification and adjustment.
- Remove the cap (1).
- Using a spanner, screw the cover (2) into the casing to the stop.
- Start the engine. Turn on the compressor and fill the bottle with compressed air so that the safety valve (6) would operate at 8.5-10 kgf/cm². If the valve operates at a pressure exceeding the said limits, adjust it by means of the screw (8), having preliminary loosened and then tightened the lock nut (7).
- Adjust the force of the springs (3, 4) by unscrewing gradually the cover (2) in such a way that the air pressure in the bottle at which the overload valve (5) opens would be 7.7-8.0 kgf/cm².
- Fix this position of the cover (2) by applying paint to the treaded part of the casing and put on the cap (1).
- Open slightly the condensate removal valve in the bottle and reduce the air pressure to 6.5-7.0 kgf/cm². At these values, the valve (5) shall become closed and switch the compressor to filling the bottle with compressed air.
- Disconnect the reference pressure gauge from the bottle.

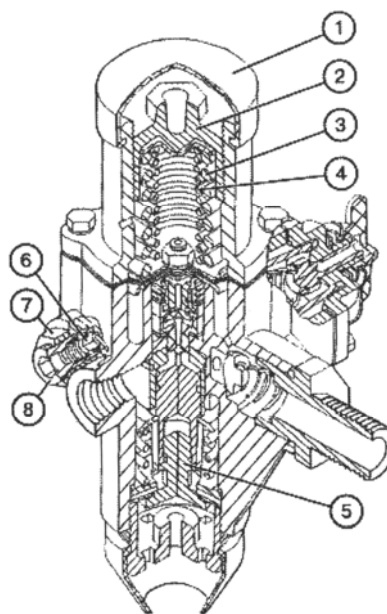

Action 25. Checking the tightness of the bolts of clamps of the CAC ducts (Belarus-900.3/920.3/950.3/ 952.3)

Check, and, tighten, if necessary, the bolts of clamps of the CAC ducts. The tightening torque of the bolts of clamps of the CAC ducts shall be from 10 to 15 N·m.

Action 26. Checking the air-tightness of the pneumatic system lines

- Bring the pressure in the pneumatic system to 6.0-6.5 kgf/cm² (as displayed by the indicator on the dashboard) and stop the engine.
- Using the pressure gauge, check that the pressure drop for 30 minutes does not exceed 2.0 kgf/cm². Otherwise, detect the air leakage point and eliminate the leakage.

Action 27. Rear PTO control

When switching from the “ON” position to the “OFF” one and vice versa, the force on lever (1) shall be within 120 – 150 N (12 – 15 kgf). Switching shall be distinct.

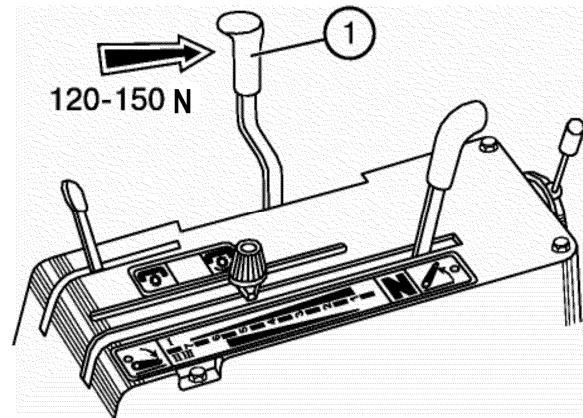

Action 28*. Front wheel toe-in

The front wheel toe-in shall be within the range 0 to 8 mm. If necessary, perform the adjusting operations according to the recommendations given in the section “Adjustments”.

* Perform Maintenance action after 250 hours of operation.

Action 30. Steering knuckles of the front axle (Belarus-900/900.3/950/950.3)

Using a gun, make 10-12 injections of lubricating grease through the pressure lubricators (one per each knuckle).

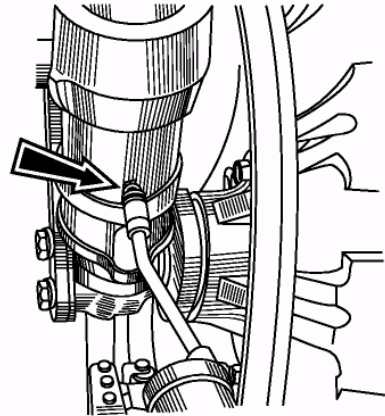

Action 31. Checking the air-tightness of the air cleaner and inlet duct joints (except for Belarus-900.3/920.3/950.3/952.3)

- Remove the monocyclone (1) and clean its internal surface.
- Loosen the clamps (2), remove the bolt (4), release the clamp (3) and remove the air cleaner (5).
- Disassemble the air cleaner, having loosened the nuts (7) and removed the tray (6).
- Clean the internal tray cavity and fill it with fresh motor oil.
- Extract three filtering elements, wash them in diesel fuel and blow with compressed air. Clean the central pipe. Reassemble the air cleaner and install it onto the engine.
- Check the air-tightness of all joints and, if necessary, tighten them up. The engine operating at medium crankshaft speed (1000 rpm) shall stop when shutting down the air intake pipe.

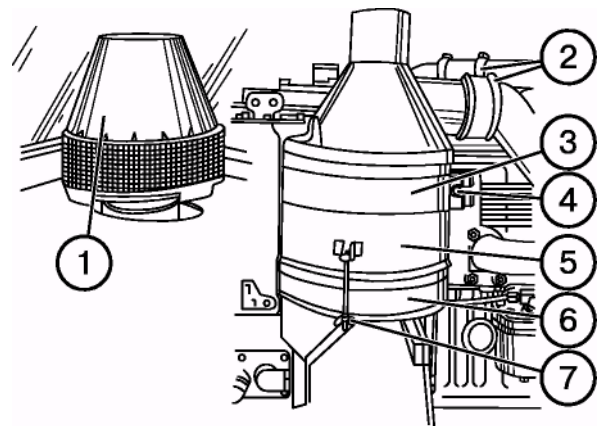

Action 32. Replacing the oil filter of the hydraulic system

NOTE: Make further replacements of the oil filter of the hydraulic system after each 1000 hours of operation.

- Remove the bolts (2) and cover (1) and extract the filtering element assembly using the arrester (4).
- Remove the nuts (3), arrester (4) and filtering element (5).
- Wash the casing (6) in washing solution.
- Install a new filtering element and assemble the filter in the reverse order.
- Mount the filter assembly into the hydraulic system tank, close it with the cover (1) and fasten it with the bolts (2).

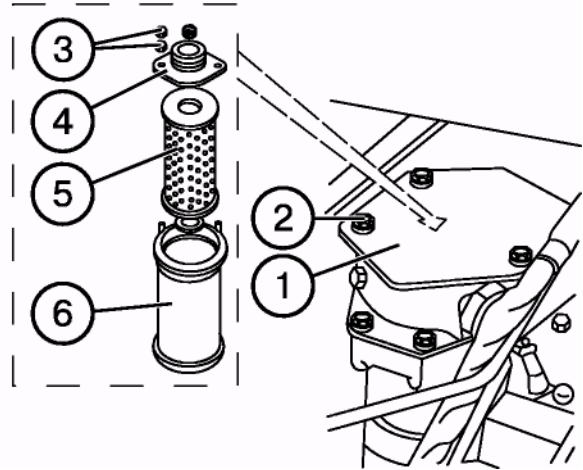

Action 32a. Replacing the filtering element in oil tank of the hydrostatic power steering (Belarus-900.3/920.3/950.3/952.3)

To get access to the oil tank, turn the retainers and remove the left side grid from the front of tractor facing.

Unscrew the bolts (1), remove the cover (2) and extract the filtering element assembly.

Install a new filtering element in the oil tank, refit the cover (2) and fasten it with the bolts (1).

If necessary, remove the oil filler neck cap (3) and add oil to the upper mark with referring to the oil meter (4).

NOTE: Make further replacements of the filter element in the oil tank of the steering system after each 1000 hours of operation.

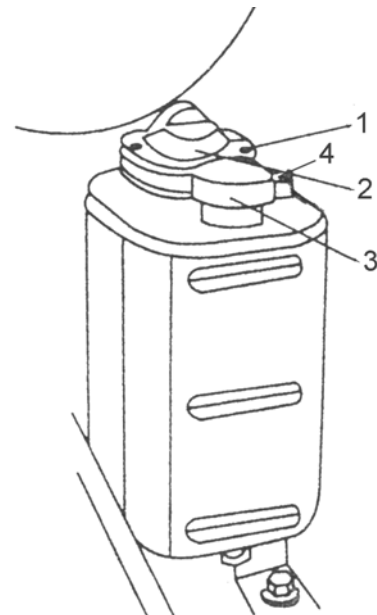

Action 33. Cleaning alternator

Clean the alternator from dust and dirt. Check and tighten, if necessary, the alternator fastening bolts (1). Check the condition and firmness of the alternator clamped connections (2).

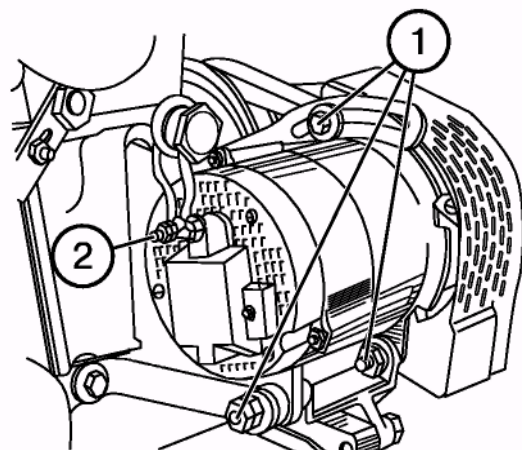

Action 34. Draining the deposit from the fuel fine filter

Remove the drain plug (1) and drain deposit until clean fuel free of water and dirt appears traces appear. Tighten the plug. If necessary, bleed the fuel system.

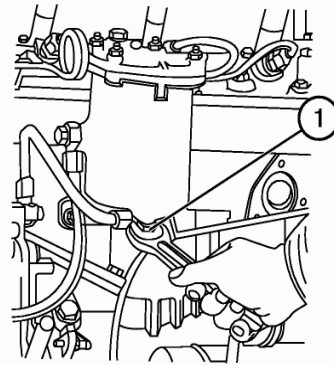

Action 35. Checking the oil level in the transmission

Check oil level by using oil-measuring rod (1) on the left side of the gearbox. The normal working oil level shall be between the upper and lower marks on the probe.

NOTE: If your tractor is equipped with f speed reducer, check the oil level against the check plug (2) located on the right side of the gearbox. The normal working oil level shall be at the lower edge of the threaded opening of the plug (2).

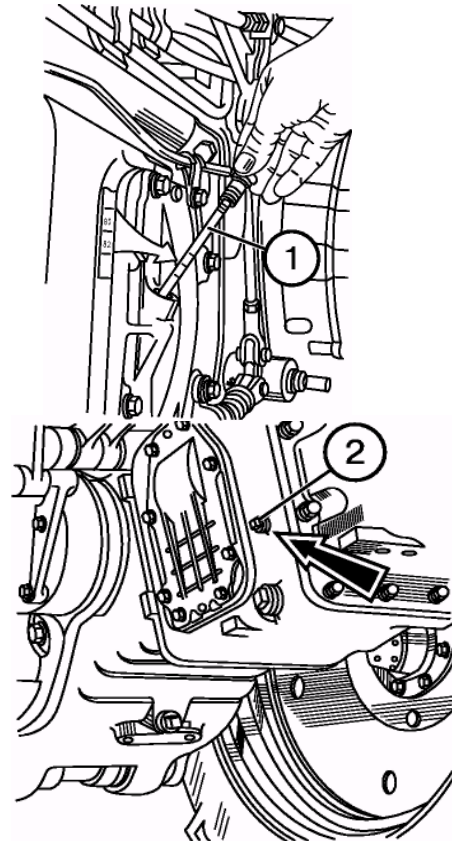

If you have to correct oil level, remove the plug (3) on the upper cover of the gearbox and add oil to the level.

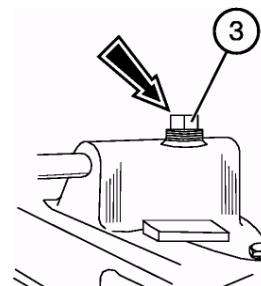

Action 35a. Checking the oil level in the casings of the “wet”-type brakes

To check the oil level in the casings of the “wet”-type brakes, proceed as follows:

- Place the tractor on a flat level area;
- Screw out the check/fill plugs (1) in the right and left casings of the brakes;
- The oil level in the casings of the brakes shall be to the edges of the holes of the check/fill plugs (1) on the front walls of the casings;
- If necessary, add oil through the holes of the plugs (1);
- Screw in the plugs (1).

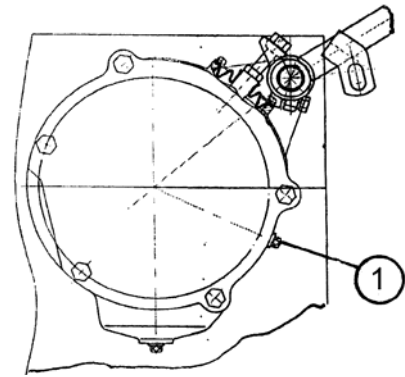

Action 36. Oil level in the FDA casings I. FDA with bevel reducing gears (920/952)

Check the oil level in the:

1. wheel reducing gears (lower bevel pairs);
2. main gear (front differential) casing;
3. cardan drive intermediate support;
4. upper bevel pair casings.

The oil level shall be to the lower edges of threaded check openings (1).

If necessary, add oil to the level through the check openings.

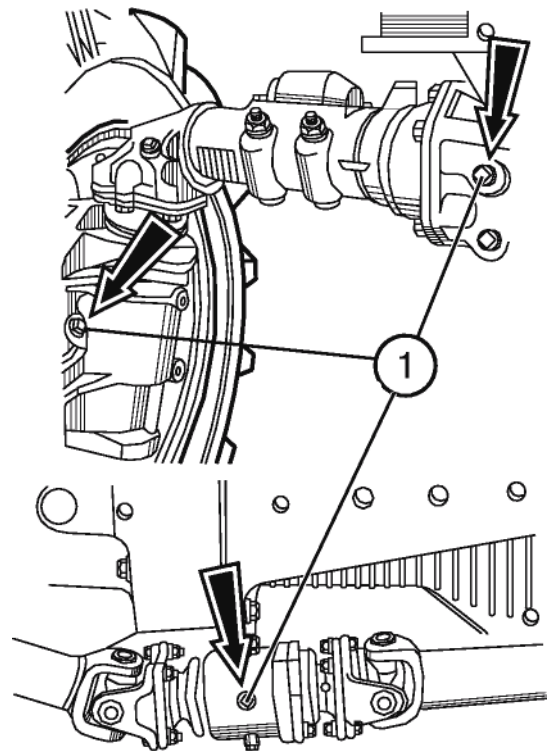

II. FDA with planetary reducing gears (Belarus-920.2/920.3/952.2/952.3)

Check the oil level:

- In the wheel reducing gears (left and right). If necessary add oil to the level of check filler opening closed with plug (1).
- In the FDA main gear. If necessary add oil to the level of check filler opening closed with plug (2).

Brands of oils to be used:

- Transmission oils ТЛп-15В;
ТСП-15К; ТСП-10; ТАД-17и;
SAE 80W-90 or their analogues.

Action 37. Bearings of the pivots of the FDA with planetary reducing gears

Check and adjust, if necessary, the tightness in the bearings.

- The preliminary tightness in pivot bearings shall be so that the knuckle turn force applied to the collar (5) would be within 60...80 N (6...8 kgf). If necessary, perform the adjustment as follows:
- Turn out the four bolts (2) and turn in the two disassembling bolts (1) into the pilot holes;
- Remove the required number of adjusting gaskets (4) from under the pivot upper axis flange (3);
- Unscrew the disassembling bolts and tighten uniformly bolts (2) with the torque of 120-140 Nm (12-14 kgf-m).

Action 37a*. Replacement of the drying filter

ATTENTION: To replace the drying filter, contact the specialized service station. The replacement shall be only performed using special equipment.

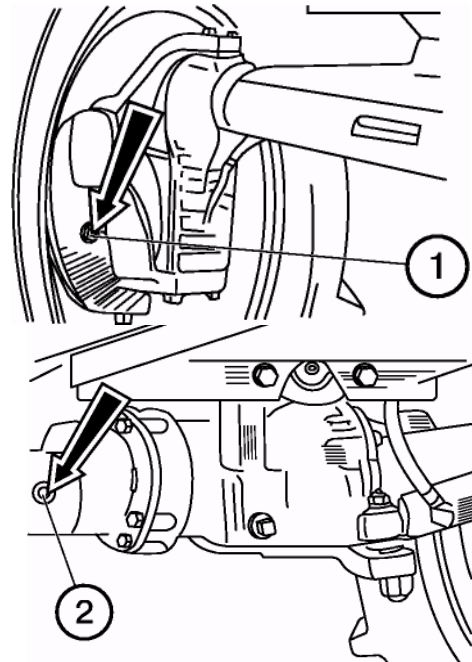

* The action shall be performed after each 800 hours or once a year

Maintenance No.3 (M-3) after each 1000 hours of operation

Perform all actions of the previous M plus the followings:

Action 38. Torque of tightening of the engine head bolts

NOTE! This operation shall be only performed on the warmed up engine.

Remove the rocker cover, cylinder head cover and rocker axle assembly.

Using a torque spanner, check and tighten the cylinder head bolts in the order shown in the figure on the right. Bolt tightening torque shall be within 160...180 N•m (16...18 kgf•m).

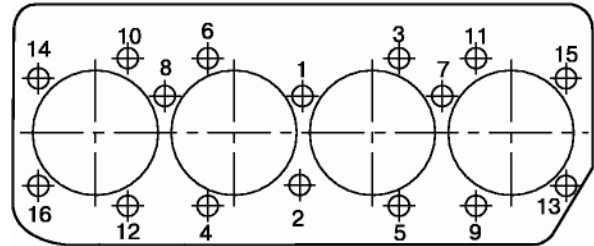

Action 39. Engine fuel coarse filter

Wash fuel coarse filter as follows:

- Shut the fuel tank valve.
- Unscrew the fastening bolts (1) of the barrel (3) and remove the barrel.
- Unscrew the deflector with the mesh (2) and remove the diffuser.
- Wash the deflector with the mesh, the diffuser and filter barrel in diesel fuel.
- Assemble the filter parts in the reverse order.
- Fill the system with fuel.
Bleed the system and remove air from fuel system as shown below (action 40).

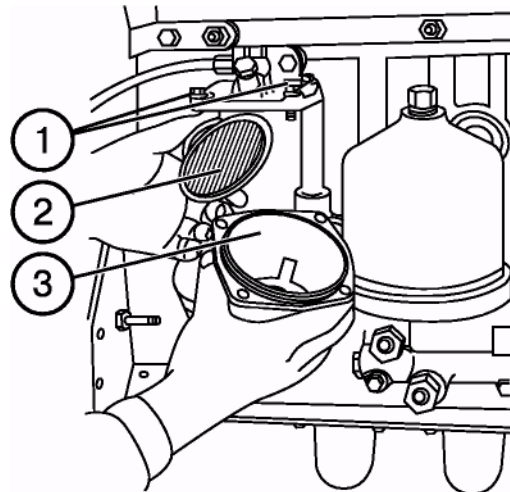

Action 40. Replacing the filtering element of the fuel fine filter

- Remove the plug (1) and drain the deposit.
- Unscrew four nuts and remove the cover (3).
- Draw out the filtering element (2).
- Wash the casing and the cover with pure diesel fuel.
- Check the cover gasket and replace it, if necessary.
- Install a new filtering element.
- Fill the filter casing with fuel.
- Replace the cover and tighten the fastening nuts.

IMPORTANT! After cleaning or replacement of the filtering element (or after fuel work-out from the tanks), air should be removed from the system prior to starting the engine.

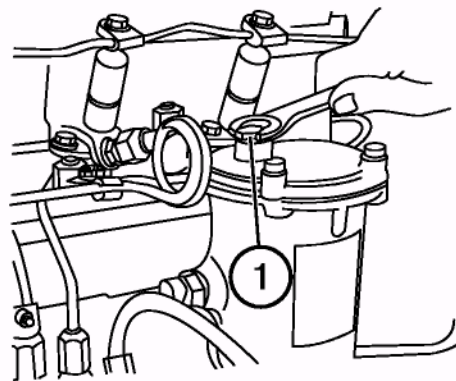
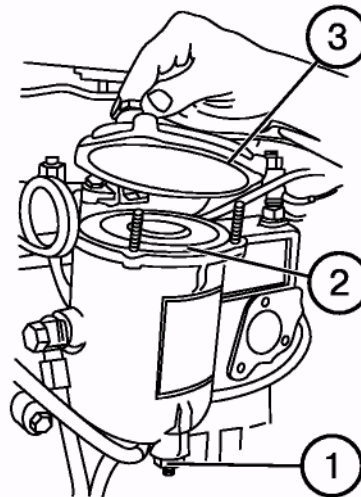

To bleed air from the system:

- Loosen the plug (1) of the fuel fine filter.
- Unscrew the boost pump handle (3).
- Check whether the fuel tank valve is open and there is fuel in the tanks.
- Loosen the plug (2) on the fuel pump.
- Bleed the system quickly by means of the boost pump until clean fuel free of bubbles appears from under the plugs. Tighten the fuel pump plug (2). Continue bleeding the system until fuel free of air bubbles appears from under the fuel fine filter plug (1).
- Screw the boost pump handle (3).

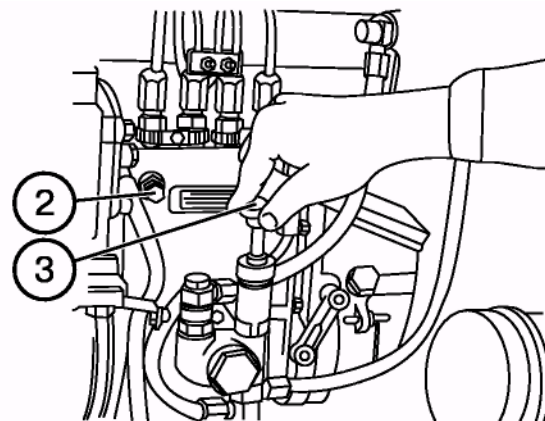

NOTE: If the engine starting is impeded, loosen the fuel line union nut of each injector and remove air from the lines by rotating the diesel engine with the starter. Rotate the engine for 10...15 s and then tighten the union nut.

Action 41. Alternator

Take the driving belt (1) from the alternator pulley (2).

Check the easy rotation of the alternator rotor and presence of plays in the bearings.

If there are any plays or jamming of the rotor, remove the alternator and send it to the shop for repair.

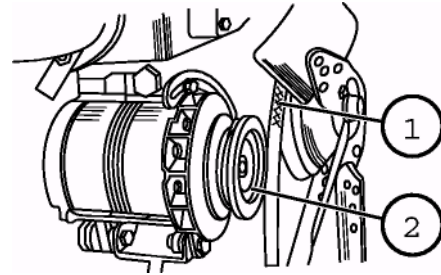

Action 42. Adjusting the front wheel bearings (Belarus-900/900.3/950/950.3)

- Apply the parking brake and place the wedges in front of and behind the rear wheels.
- Lift the front axle from the ground and place a rest under the front axle.
- Unscrew the bolts (1) and remove the cover (2) and gasket (3).
- Remove the cotter pin (4), nut (10), ring (5) and external bearing (9).
- Remove the wheel hub as an assembly and squeeze the internal bearing (8), race (6) and cup (7).
- Wash all the parts in diesel fuel.
- In case of wear or damage of the bearing and cup, replace them with new ones.
- Reassemble all the dismantled parts in the reverse order.
- Fill in the gap between the bearings inside the hub with lubricating grease to half space.
- Tighten the nut (10) with the torque of 20 N•m (2 kgf•m). Release the nut until the cut is aligned with the axle opening and lock the nut.
- Fill the inner cavity of the cover (2) with grease to half space.
- Repeat the above steps for another wheel.

Action 43. Steering rod joints (Belarus-900/900.3/950/950.3)

When the engine is running, turn the steering wheel in both direction to verify the free travel and plays in the joints (1) of steering rod (4).

If there are any plays in the joints, proceed as follows:

- Remove the safety wire (3);
- Tighten the threaded plugs (2);
- Lock the plugs with wire (3).

NOTE: If the play in the joints cannot be eliminated by tightening the threaded plugs, disassemble the joint and replace worn-out parts.

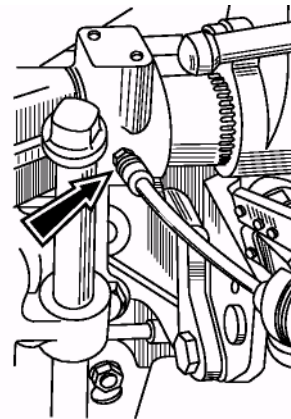
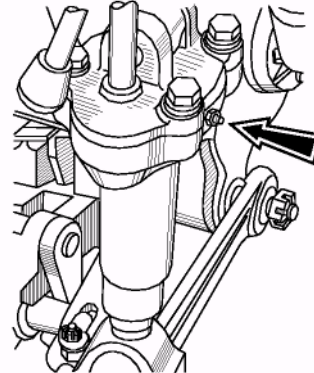
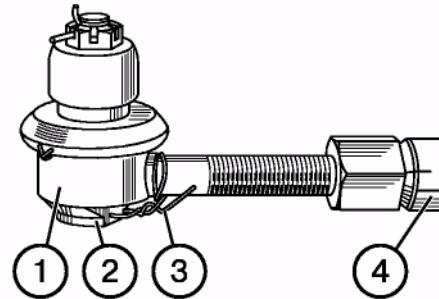

Action 44*. Lubricating RMA right angle brace bearing

Grease the adjustment mechanism of the right angle brace through the pressure lubricator (one point of greasing) using a gun. Make 4...6 injections with the gun. The "Litol-24" grease should be used.

Action 45*. Lubricating the bushings of the RMA rotary shaft

Apply the grease by means of a gun to the two lubrication points through the pressure lubricators in the mounted attachment holder until grease appears from the gaps. The "Litol-24" grease should be used.

Action 46. Outside bolted connections

Check and tighten, if necessary, the critical bolted connections:

- front and rear wheel nuts and rear wheel hub bolts;
- front beam – semi-frame side members;
- semi-frame side members – clutch casing;
- THM plate fastening;
- diesel engine – clutch casing;
- clutch casing – gearbox casing;

gearbox casing – rear axle casing;
rear axle casing – RMA and THM holders;

front and rear supports of the cab;
holders and pins of the steering hydraulic cylinder;
rear axle casing – semi-axle sleeves;
FDA casing – sleeves – wheel reducing gears;
nuts of the cardan shaft collars;
nuts of the FDA casing wedges;
casing of the cardan drive intermediate support – clutch casing;
fastening of the holders of the lifting THM and hydraulic lift.

* For tractors equipped with hydraulic lift of RMA, actions 44 and 45 are excluded.

Action 47. Changing oil in the hydraulic system

- Prior to changing oil, warm up oil in the hydraulic system.
- Place the tractor on the flat ground, lower and detach the mounted machine.
- Brake the tractor and stop the engine.
- Unscrew the filler cap (2) (see page F8) and the drain plug (1) from hydraulic system tank and drain oil into waste oil vessel.

ATTENTION! Be careful to avoid contact with hot oil. Dispose of waste oil properly.

- Replace the drain plug (1) and fill the system with fresh oil. Refit the filler cap (see Action 3).

NOTE: When using the machines requiring large amount of oil taking, add oil to the level corresponding to the upper mark "C". When doing this, the hydraulic cylinders shall be with plungers indrawn.

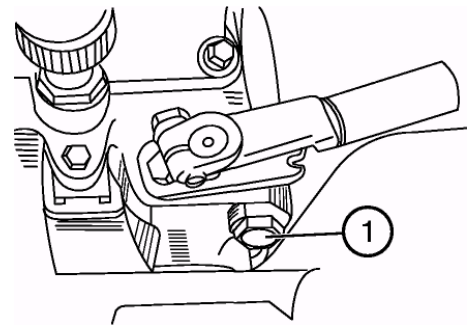

Action 47a. Changing oil of the HPS (Belarus-900.3/920.3/950.3/952.3)

- Follow the recommendations given for the above action. To get access to the HPS tank, lift the engine facing upwards to the stop and fix it safely in the lifted position.
- Remove the filler neck cap (2) and the drain plug (3). Drain oil from the tank into waste oil vessel. Dispose of oil properly.
- Replace drain plug (3) and fill in fresh oil "BECHEM Staroil No. 32", or "Hessol Hydraulikoil HLP 32".
- The oil level shall be up to upper mark on oil-measuring rod (1).
- Replace cover (2). Lower the engine facing.

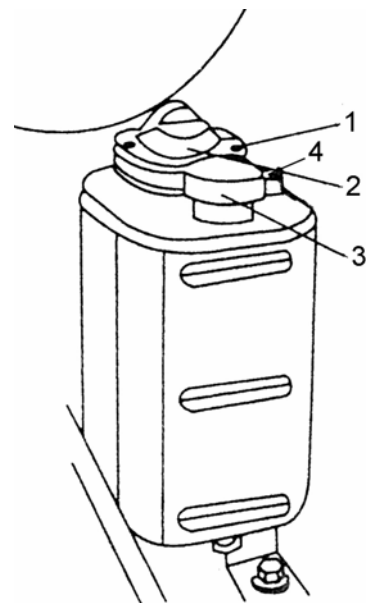

Action 48. Changing oil in the transmission

- Prior to changing oil, warm up the transmission.
- Place the tractor on the flat area, lower the mounted machine and stop the engine.
- Engage the parking brake and lock the wheels against movement by using wedges.
- Unscrew the check plug (2) and drain plugs (1) from the casings of rear axle and gearbox, and drain oil into a special waste oil vessel. Dispose of oil properly.

ATTENTION: Be careful to avoid contact with hot oil.

- Fill in transmission with fresh oil. Replace the check plug (2).
- Unscrew the check filler caps (1) and drain plugs (2) of the left and right “wet”-type brake casings and drain oil as stated above.
- Screw in the drain plugs.
- Fill in the casings with fresh transmission oil up to the lower edge of check filler openings.
- Screw the plugs (1).

Action 48a. Changing oil in the casings of the “wet”-type brakes

To drain oil from the casings of the “wet”-type brakes, proceed as follows:

- Place the tractor on a flat level area;
- Unscrew the check/fill plugs (1) in the right and left casings of the brakes;
- Unscrew the drain plug (2) in the right and left casings of the brakes and drain oil into a special waste oil vessel;
- Screw in the check plugs (2);
- Pour oil into the both casings through the holes of the check/fill plugs (1).

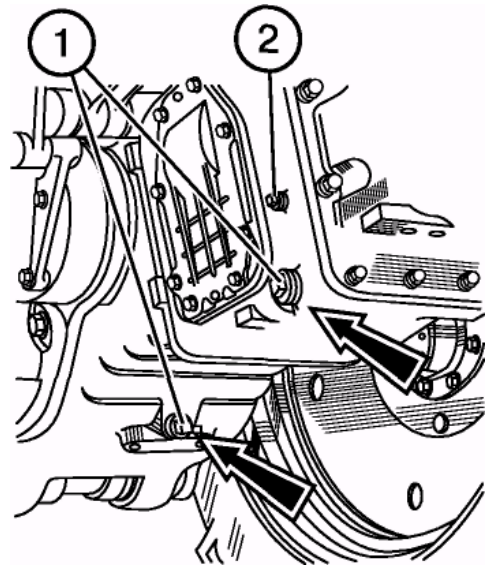

NOTE:

1. The oil changing operations in the casings of the brakes shall be performed simultaneously with the change of oil in the transmission. The brand of the oil to be used for the brakes shall be similar to that in the transmission.
2. The total volume of oil poured into both casings of the brakes shall be 2.5 ± 0.1 litres

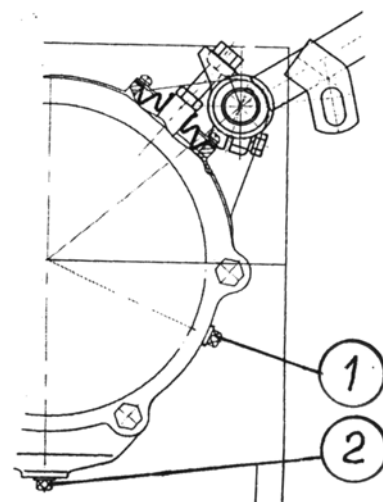

Action 49. Changing oil in the FDA casings and intermediate support

I. FDA with bevel reducing gears (Belarus 920/952)

- Prior to changing oil, warm up oil in the FDA casings.
- Place the tractor on a flat horizontal area. Engage the parking brake and lock the rear wheel with wedges from the front and behind.
- Unscrew the check filler caps (1) and drain plugs (2, 3, 4) from the casing of wheel reducing gears, main gear and intermediate support, respectively. Drain oil into a special vessel.

ATTENTION! Be careful to avoid contact with hot oil. Dispose waste oil properly.

- Screw in and tighten the check plugs.
- Fill the casings with fresh transmission oil Тар-15В, Тсп-15К, Тсп-10, ТАД-17и or their analogues to the level of lower edges of the filler openings. To drain oil from upper bevel pair casing:
 - Using the gun (3) for liquid lubricant, pump out some oil through the filler opening (4);
 - Unscrew the bolts (2), remove the cover (1) and drain the remaining oil;
 - Replace the cover (1) and bolts (2);
- Fill in the spaces of upper bevel pairs up to the lower edges of the opening (4) using the gun for liquid lubricant.
- Replace and tighten all the check/fill plugs.

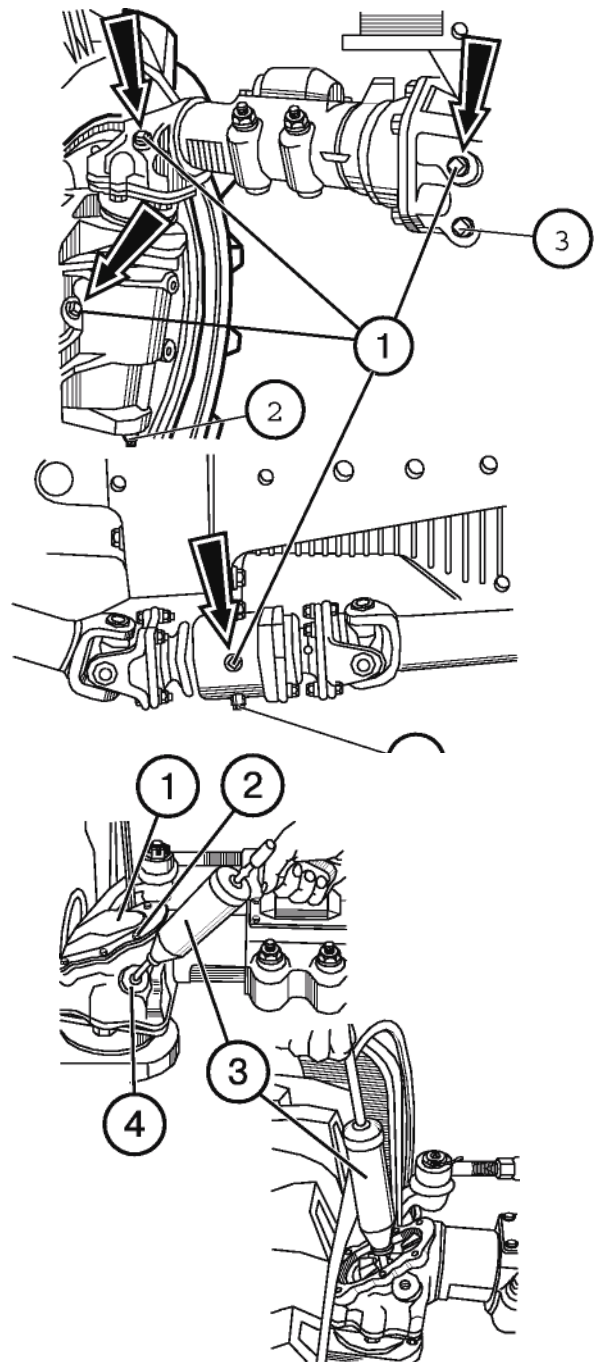

II. FDA with planetary reducing gears (Belarus-920.2/920.3/952.2/952.3)

- Let the tractor run for some time and warm up oil in FDA casings.
- Place the tractor on the horizontal area. Stop the engine. Apply the parking brake and lock the wheels with wedges from both sides.
- Turn out the check/fill plugs (shown by arrows) and the check plugs (1, 2, 3) from the casings of wheel reducing gears, main gear and intermediate support and drain oil into a special waste oil vessel. Dispose of oil properly.
- Refit and tighten the check/fill plugs.
- Fill the casings with fresh transmission oil (Тан-15В, ТСп-15К, ТСп-10, ТАД-17и or their analogues) up to the lower edges of check filler openings.
- Refit and tighten the check/fill plugs.

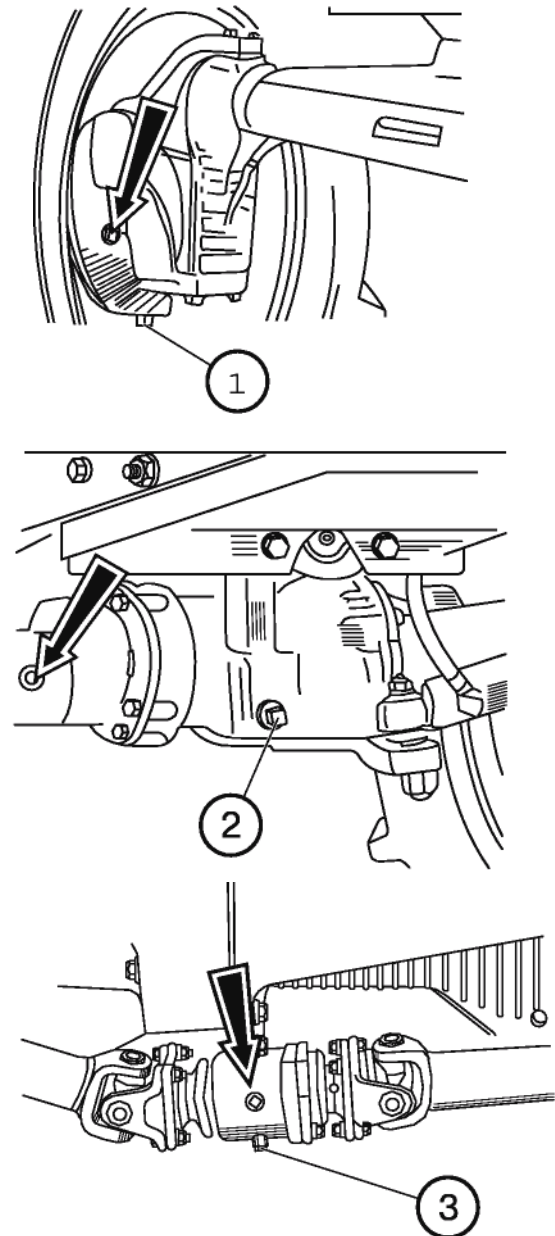

Action 50. Bearings of the FDA planetary reducing gear flange

Check and adjust, if necessary, the bevel roller bearings (3, 5) without plays by performing the following operations:

- Unscrew the bolts and remove the cover (2);
- Tighten the nut (1) with the torque of 180-200 N·m (18-20 kgf·m) and then unscrew it by 15-20°;
- Punch off the nut in two cuts of the flange (4). Replace the cover (2);

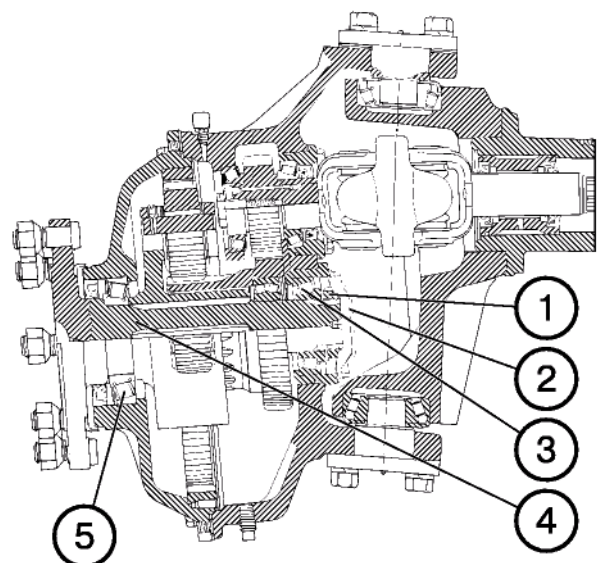

Action 51. Washing the primary oil filter of the engine

- Loosen four clamps of connector sleeves and remove the filter from oil line located in front of the engine oil radiator.

IMPORTANT! Note the filter orientation in the oil line. Arbitrary installation of the filter is not allowed.

Wash the filter in diesel fuel and blow it with compressed air in the direction of the arrow on the filter body.

Replace the filter, paying attention to its correct orientation in the oil line.

Tighten the sleeve clamps.

Action 52. Washing the engine breather

- Unscrew the bolts (1) and remove the breather casing (2).
- Remove the breather from the casing, wash it in diesel fuel and blow it with compressed air. Pour some motor oil into the breather filter and letting the oil to flow down, fit it back.

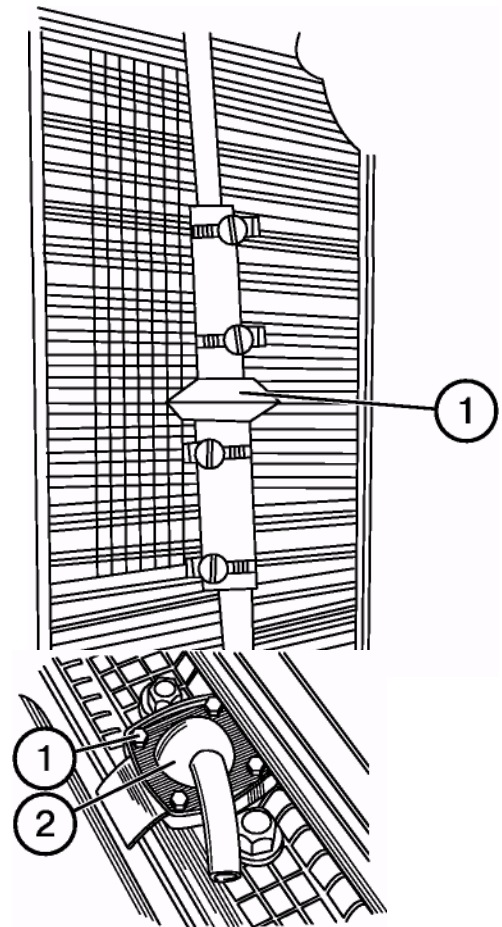

Special maintenance

After each 2000 hours of operation

Action 53. Checking the diesel engine injectors

IMPORTANT! The injectors shall be cleaned and adjusted in a dealer's specialized workshop.

WARNING: Diesel fuel is injected under high pressure and can be a source of serious injuries, if the injector atomization is checked by hand. Use a piece of paper or cardboard for this purpose. Put on protective goggles. Prior to connection or disconnection of fuel lines, stop the engine to take pressure down. Prior to starting the engine, tighten all connections of fuel lines. In case of fuel injection on the hand skin, immediately apply for medical aid, otherwise blood poisoning is possible.

NOTE: It is convenient to have a spare set of injectors verified and adjusted for quick installation into the engine.

Take the injectors out and replace them. To do this, proceed as follows:

- Prior to disconnection or loosening of any fuel system parts, clean fully the adjacent working surfaces.
- Turn out the nuts (4) and disconnect the high-pressure fuel piping (5) from the injectors (3) and fuel pump.

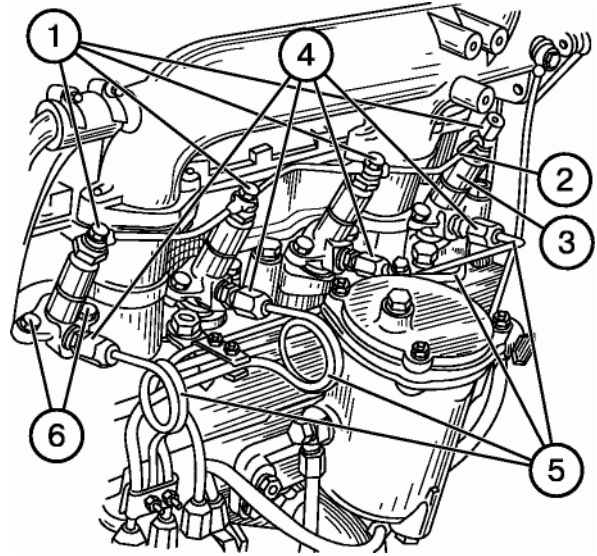

- Remove the fuel piping.
- Turn out four bolts (1) of the drain line and take the rundown fuel piping (2) away. Discard copper sealing washers (two washers per each "banjo" bolt).
- Unscrew the bolts (6) fastening the injectors and remove the injectors (3).
- Send the injectors for servicing to dealers workshop.
- Install the verified, cleaned and adjusted injectors by performing the above specified step in the reverse order.
- Remove air from the system.

IMPORTANT! During each injector installation, use new copper washers.

Action 54. Fuel pump injection advance angle

Setup advance angle of fuel pump injection shall be within 17° to 19° before top dead centre (TDC) (Д-245.5) and from 19° to 21° before TDC (Д-243).

Verifying and adjusting the fuel injection advance angle is performed in a specialized dealer shop.

When installing the "Motorpal" (Czechia) in-line fuel pump, the setup advance angles of the injection shall be as follows:

- 15...17° before the TDC (Belarus-900//920/920.2).
- 12...14° before the TDC (Belarus-950/952/952.2).
- When installing the YAZDA fuel pump for diesel engines Д-245.5 S2 (Belarus-950.3/952.3) and Д-245.43 S2 (Belarus-900.3/920.3), setup advance angle of injection shall be within 3.5°...4.5° before the TDC.

IMPORTANT! Adjustment of the fuel equipment by the tractor operator (owner) is the ground for rendering the manufacturer's warranties void.

Action 55. Adjusting the fuel pump on the bench

Adjusting the fuel pump shall be performed made by the dealer in a specialized shop using special equipment.

Action 56. Flushing the engine cooling system

To flush the system, use a solution of 50-60 g of soda ash per 1 l of water. To flush the system, proceed as follows:

- Pour 2 l of kerosene into the radiator and fill the system with the prepared solution;
- Start the engine and operate the tractor for 8-10 hours; then drain the solution and flush the cooling system with clear water;

- check the cleanness of the radiator core. If necessary, wash the radiator and blow the core with compressed air (blowing direction from the engine side).

ATTENTION! Radiator clogging, insufficient fan belt tension and impurities inside the cooling system can lead to diesel engine overheating and failure.

Action 57. Starter of the engine

- Unscrew the screws (1) and remove the cover (2).
- Check the condition of the commutator (3), brushes (5) and springs (4).
- Make sure of free brush movement. The brush pressure on the commutator surface shall be within 0.75-1.00 kgf. Otherwise, replace the brush holder as an assembly.
- In case of considerable wear or burning of the commutator surface, send the starter to the repair shop.

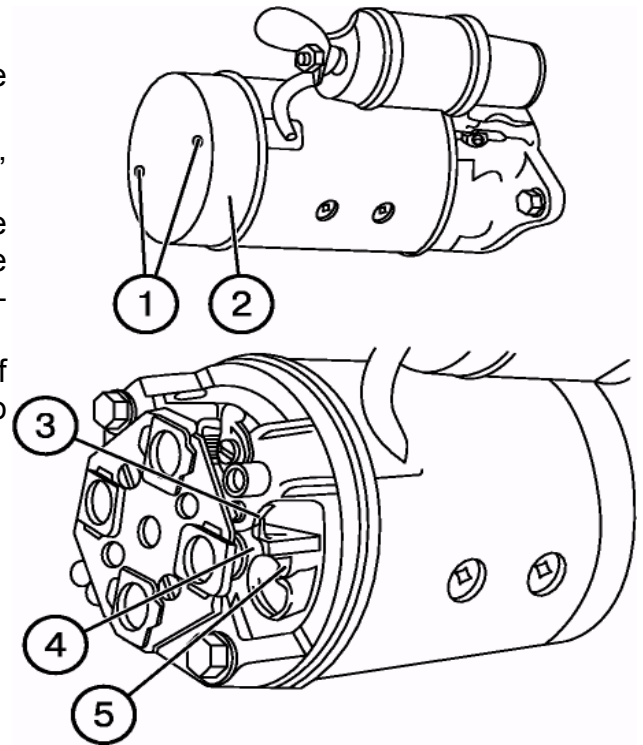

General maintenance

Action 58. Adjusting the drain valve of the centrifugal oil filter of the engine (except for Belarus-900.3/920.3/950.3/952.3)

If during the engine operation within the rated mode at normal temperature (80-100°C), the oil pressure has dropped below 0.1 MPa, stop the engine and eliminate the defect.

One of the ways to increase pressure is readjustment of the centrifuge drain valve. To do this, remove the thread plug (not shown) and readjust oil pressure by screwing the adjustment screw (1) with a screw-driver into the body. If this method does not eliminate the defect, contact the dealer.

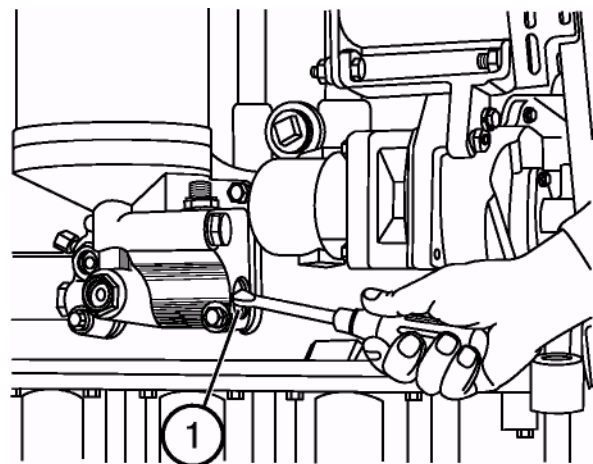

Seasonal maintenance

Combine the seasonal maintenance with the action under regularly scheduled maintenance

Work content	
When transferring to the autumn and winter period (at constant mean daily temperature below +5°C)	When transferring to the spring and summer period (at constant mean daily temperature above +5°C)
<p>Replace the summer oil brands with winter ones (see lubrication table):</p> <ul style="list-style-type: none"> in the engine crankcase; in the casings of the hydraulic units; in the transmission casing; in the casings of the “wet”-type brakes (if provided); in the FDA casing; in the FDA final drive reducing gear casings; in the FDA drive intermediate support <p>Screw in the screw of seasonal voltage adjustment on the alternator to the stop (position “3” – winter)*</p> <p>Replace grease in front wheel hubs</p> <p>Fill engine cooling system with a fluid not freezing at low temperature, having preliminary flushed the cooling system</p> <p>Clean setting opening of electric torch pre-heater connecting branch bolt (except for “Belarus-900.3/920.3/950.3/952.3”)</p> <p>Remove the cardan shafts away and check the tightness of the flange seating axially on the distribution box shafts, intermediate support and main gear driving pinion (of the tractors with the FDA). Eliminate axial plays by tightening the nuts.</p>	<p>Replace the winter oil brands with the summer ones in:</p> <ul style="list-style-type: none"> in the engine crankcase; in the casings of the hydraulic units; in the transmission casing; in the casings of the “wet”-type brakes (if provided); in the FDA casing; in the FDA final drive reducing gear casings; in the FDA drive intermediate support <p>Set the seasonal adjustment screw on the alternator to position “Л” – summer</p>

* Only for alternator having manual seasonal adjustment of voltage.

Tractor maintenance under special operation conditions

When operating the tractor under special conditions (low temperatures, in the desert, on sand, swampy and rocky soils), customary regularity and volume of maintenance are preserved.

Besides, below listed works are introduced additionally or carried out more often.

When operating the tractor in the desert, on sand soils, at higher temperatures and air dustiness conditions.

Fill the engine with oil and fuel by closed method. After each three shifts, change oil in the air cleaner tray.

When performing M-1, check:

- oil in the engine, presence of mechanical impurities in oil is not allowed. Replace, if necessary;
- central air cleaner pipe (the pipe shall be clean). Wash and service the air cleaner after each 20 hours;
- flush the water radiator core with water jet or blow with air. The radiator shall be clean; there shall be no oil traces on its surface. When performing M-2, wash fuel tank plug.

When operating the tractor at low temperatures, perform the pre-start heating of the engine to 20-30°C. At the end of the shift fully refuel the tanks) at the temperatures of minus 30°C use arctic fuel) and drain condensate from the bottle. Fill the cooling system with anti-freeze.

When operating the tractor on rocky soil, as well as under mountainous conditions.

Every shift inspect visually the running gear and other components of the tractor for damages, as well as tightening of plug of the engine crankcase, rear axle and FDA as well as fastening of driving wheels. Check the air-tightness of engine cooling

system radiator plug.

Under mountainous operating conditions, adjust the fuel pump to reduce its output capacity to avoid disturbance of the engine working process within the following limits:

- at 1500-2000 m above sea level, reduce output capacity by 10%;
- at 2000-2500 m – by 15%;
- at 2500-3000 m – by 20 %;
- operation at more than 3000 m is not recommended..

Maintenance of the tractor when preparing it for storage, storing and returning to operation

The tractor is maintained under stated conditions according to regulations stipulated in Chapter “Tractor Storage”

LUBRICATION TABLE

Units and points of lubrication	Standard name, brand and description of the lubricating materials and liquids				Amount of lubricating points
	Lubricant at operation temperature		Refill at operation, l	Greasing at storing (up to 6 months)	
	From -40°C to +5°C	From +5°C to +50°C			
Crankcase	M-8ДМ M-8Г _{2К} , M-8Г ₂	M-10ДМ M-10Г _{2К} , M-10Г ₂	Motor oil Standard 12.0 Backup	12.0	1
Air cleaner tray	Pre-settled and filtered waste motor oil		1.7 3.0 (Д-245.5)	1.7 3.0 (Д-245.5)	1
Power train casing			Standard		
"wet"-type brake casings (if installed)	Transmission oil Тпн-15В*; Тсп-15К; Тсп-10	Тсп-15К	40	40	1
			1.5 (left) 1.0 (right)	1.5 (left) 1.0 (right)	1 1
			Backup		
FDA final drive reducing gear casings	Transmission oil ТАД-17и ----	Transmission oil ТАД-17и ----	1.8 (2.0)**	1.8 (2.0)**	2
FDA casing	Ditto	Ditto	1.6 (3.7)**	1.6 (3.0)**	1
Upper bevel pair casings of FDA reducing gears	----	----	0.25	0.25	2
FDA drive intermediate support	----	----	0.15	0.15	1
Driving pulley	-----	----	0.50	0.50	1

* At the temperature of -15°C to -20°C, dilute 30% of the refilling volume with spindle oil AY State Standard ГОСТ 1642-75 or machinery oil И-12А State Standard ГОСТ 20799-75. At the temperature of up to -55°C, dilute up to 15% of the refilling volume with winter diesel fuel.

** The refill capacities are given in parentheses for the FDA with planetary reducing gears (Belarus-920.2/920.3/952.2/952.3)

Units and points of lubrication	Standard name, brand and description of the lubricating materials and liquids			Amount of lubricating points
	Lubricant at operation temperature		Refill at operation, l	
	From -40°C to +5°C	From +5°C to +50°C		
Oil tank of hydraulic system and HPS	Motor oil M-8Г _{2K}	Motor oil M-10Г _{K2} , M-10Г ₂		
	Standard			
	Backup			
HPS oil tank (900.3,920.3,950.3,952.3)	Machinery oil "Bechem Staroil No. 32", И-30А; "Hessol HydraulikHLP32		25.0 6.0	---- ----
Clutch shifter bearing	Standard grease "Litol-24" Backup grease "Bechem" LCP-GM multi-purpose plastic		4-6 injections by gun (0.02)	----
Front wheel hub bearing (900/950)	Ditto		0.40	ditto
Front axle steering knuckle (900/950)	----		10-12 injections by gun (0.05)	----
Adjustable angle brace pinion	----		0.005	
Rotary shaft sleeves of rear mounted attachment	Ditto		Until grease appears from the gaps (0.01)	----
Steering hydraulic cylinder joints	Ditto		0.0125	----
Axles of pivot of FDA with planetary reducing gears	----		0.03	----

Refill capacities, l

Engine cooling system	17
Engine lubrication system	12
Transmission casings	40
Casing of the FDA with bevel reducing gears	1.6
Casing of the FDA with planetary reducing gears	3.7
Casing of reducing gear with bevel transmission (each)	1.8
Casing of planetary reducing gear (each)	2.0
Oil tank of hydraulic and HPS (except for Belarus-900.3/920.3/950.3/952.3)	25.0
Fuel tanks (2 tanks/1 tank)	130/140
Casing of FDA cardan drive intermediate support	0.15
Casing of FDA reducing gear (each)	0.25
HPS oil tank (Belarus-900.3/920.3/950.3/952.3)	6.00
Casing of "wet"-type multi-disk brake (left)	1.50
Casing of "wet"-type multi-disk brake (right)	1.00

TROUBLESHOOTING

TROUBLE, EXTERNAL MANIFESTATION	REMEDY
ENGINE	
The engine fails to start	
Air in the fuel system.	Pump the system with manual priming pump. If necessary, eliminate air inflow.
Faulty fuel pump.	Take fuel pump away and send it to the shop for repair.
The engine fails to develop the full power	
There is no full fuel feed due to misalignment of fuel pump control rods.	Adjust control rods.
Filtering element of fuel fine filter is clogged.	Replace filtering element.
Faulty injectors.	Locate the faulty injectors, wash and adjust them.
Wrong fuel injection advance angle.	Set the recommended injection advance angle.
Engine air cleaner is clogged.	Perform the service of the air cleaner.
The engine runs unstably at idling	
Ingress of air into the fuel system.	Remove air from fuel system.
Idling springing the fuel pump is not adjusted.	Adjust idling spring (for engines with fuel pump 4YTHM or 4YTHH).
Faulty fuel pump.	Remove the fuel pump from the engine and send it for repair.
The engine fumes at all the operation modes	
A. Black fume is emitted from the exhaust pipe	
Engine air cleaner is clogged.	Service the air cleaner.
Injector atomizer needle sticking. Injector atomizer needle sticking.	Detect the faulty injector, wash or replace the atomizer, if necessary adjust the injector.
Poor fuel quality.	Replace fuel with the recommended one.
Faulty fuel pump.	Remove the fuel pump from the engine and send it for repair.
B. White fume is emitted from the exhaust pipe	
Engine is not heated.	Warm up the engine; maintain the cooling liquid temperature within 75 - 95°C during operation.
Clearances between the valves and the rockers are not adjusted.	Adjust clearances.
Water in the fuel	Replace the fuel.
Fuel injection advance angle setting is disturbed.	Set the recommended fuel injection advance angle.
C. Blue fume leaves the exhaust pipe	
Ingress of oil into the combustion chamber as a result of wear of cup-piston group components	Replace the worn-out parts of the cup-piston group.
Excess of oil in the engine crankcase.	Drain the excessive oil, having set the level against the upper mark of oil-measuring rod.
The engine overheats	
Cooling fluid boils in the radiator. Poor fuel atomization by the injectors.	Clean the radiator from dirt and dust, if necessary, clean cooling system from scale; adjust the fan belt tension. Detect the faulty injectors, wash, clean and adjust them.

TROUBLE, EXTERNAL MANIFESTATION	REMEDY
Oil pressure in heated engine is below the allowable level	
Pressure sensor or indicator is faulty.	Replace them by new ones.
Engine lubrication system pump is faulty.	Eliminate the failure or replace the pump.
Oil level in the crankcase is below the allowable level.	Add oil to the upper mark of the oil-measuring rod
Sticking of the drain valve of centrifugal oil filter.	Wash up the valve and adjust the pressure.
Maximum wear of coupling "crankshaft journal – bearings"	Send the engine for repair
Turbocharger	
Turbocharger rotor does not rotate (absence of typical high tone sound)	
Ingress of foreign objects hampering the rotor rotation	Remove the inlet and exhaust branch pipes. Remove the foreign objects.
Jamming of the rotor in the bearing.	Replace the turbocharger.
Higher oil emission from the compressor or turbine side, loss of air-tightness of turbocharger seals.	Remove the turbocharger from the engine and send it for repair.
POWER GEAR CLUTCH	
The clutch does not transfer the full torque	
No free travel of the pedal.	Adjust the free pedal travel.
Driven plate linings are worn out.	Replace the linings of the driven plate as an assembly.
The clutch is not disengaged fully	
The free pedal travel is increased.	Adjust the free pedal travel.
Ingress of oil into the dry section of the clutch housing	
Wear of the cup sealing the crankshaft.	Replace the cup.
FINAL GEAR	
Higher noise in bevel pair	
Maladjustment of engagement of the final gear pinion teeth coupling with differential bearings.	Adjust the gap in the engagement of the pinions (0.20...0.55 mm) and preloading of the differential bearings (the turning force to be applied to the driven pinion shall be 30...50 N)
AUTOMATIC DIFFERENTIAL LOCK	
Automatic differential locking (ADL) fails to operate	
No voltage supply to the hydraulic distributor electromagnet.	Check electric circuit from the control panel to the electromagnet in accordance with the diagram.
Sticking of electric hydraulic distributor slide due to soiling.	Press the electromagnet button to move the slide.
The ADL clutch plates are oiled.	Wash the clutch plates in gasoline, eliminate oil leakage.
Friction linings of clutch disks are worn out.	Replace the plates.
BRAKES	
Ineffective brake operation (the brakes do not hold)	
Maladjustment of the brake control.	Adjust the brake control.
Brake disk linings are oiled or worn out (for "dry" brakes)	Eliminate the oil leakage. If necessary, replace the plates.

ATTENTION! A frequent cause of failure of the tractor brakes is the use of trailing and semi-trailing brakeless machines blocked with the tractor brakes. It is not allowed to use trailing and semi-trailing brakeless machines blocked with the tractor brakes if their mass exceeds half mass of the tractor.

TROUBLE, EXTERNAL MANIFESTATION	REMEDY
REAR PTO	
Rear PTO does not transfer full torsion torque(slips)	
Maladjustment of the control mechanism due to considerable wear of the friction linings of the brake band or owing to other reason.	Adjust the PTO control mechanism.
Unclear switching of the PTO control lever (occurrence of jamming, resting-against, clogging, etc. in mechanism joints).	Eliminate the reasons hampering the free movement of the control mechanism parts. The control lever must be clearly fixed in positions "PTO ON" – "PTO OFF".
FRONT DRIVING AXLE	
The front axle fails to engage automatically during the rear wheel slipping, when the tractor moves forward	
The parts of the free running coupling of the transfer box are worn out.	Replace the free running coupling.
The jamming slots of the external casing of the free running clutch are clogged with the products of oil oxidation and part wear.	Remove the coupling and wash its parts.
The springs of the roller pressing mechanism are deformed.	Replace the springs.
The safety coupling in the intermediate support does not transfer the required torque.	Adjust the coupling for transferring the torque of 50...70 kgf-m (500...700 N·m) by tightening the collar nut from the transfer box side.
The driving and driven plates of the safety coupling are worn out.	Replace the plates.
The disk springs have lost resilience or got broken.	Replace the springs.
Transfer box control rod has increased length.	Adjust the rods length as described in Chapter E. Adjustments.
Quick wear and peeling of front wheel tires	
Non-compliance of air pressure in the tyres of the front and rear wheels with the recommended norms.	To prevent faults, maintain the air pressure in the tyres of the front and rear wheels according to the recommended norms.
Misalignment of the wheel toe-in. The FDA is constantly engaged due to breakage or jamming in transfer box control.	Perform the adjustment. Check the forced engagement of the FDA. Eliminate the fault. Adjust transfer box control mechanism.
HYDRAULIC VOLUMETRIC STEERING SYSTEM (SS)	
Higher force on steering wheel	
Insufficient oil pressure in SS hydraulic system. The feed pump is faulty.	Have the pump repaired or replace it.
Insufficient quantity of oil in the tank.	Add oil to the level
Increased friction between mechanical parts of the steering column	Eliminate.
Absence of stop when rotating the steering wheel	
Insufficient quantity of oil in the tank.	Add oil and bleed the system.
Spontaneous rotation of the steering wheel ("motoring") when operator's impact is removed from it	
Failure of the metering pump spool to return to neutral position. a) blocking-up the spline shank of steering column cardan in the metering pump drive shaft	Adjust the steering column.
b) increased friction between mechanical parts of the steering column.	Eliminate.

TROUBLE, EXTERNAL MANIFESTATION	REMEDY
Non-conformance of the direction of the guide wheel turn to that of the steering wheel rotation	
Wrong connection of the cylinder outlets of the metering pump to turning cylinder.	Change the connection
HYDRAULIC MOUNTED SYSTEM	
A. Without hydraulic lift	
No lifting of the mounted attachment with an agricultural implement	
No pressure in the hydraulic system:	
Sticking of the bypass valve;	Remove the valve parts, wash them and refit into the body. The valve shall move freely.
Clogging of the safety valve;	Disassembly the safety valve, wash its parts and reassemble it. Adjust the valve operation pressure within 18...20 MPa.
Maladjustment of the governor control rod length.	Adjust, as described in the section "Adjustments".
No forced lowering of the mounted attachment	
Maladjustment of the governor control rod.	Adjust as described in the section "Adjustments".
Too slow lifting of the mounted attachment with an agricultural implement	
Air inflow into the hydraulic system.	Detect the inflow place and eliminate the defect.
Heavy oil leakages in the pump.	Check the pump capacity; replace the pump, if necessary.
Oil foaming in the tank and splashing through the breather	
Air inflow into the system via suction line.	Tighten the fastening and replace the suction connection gaskets, if necessary.
Air inflow through the self-moving cuffs of the oil pump of the hydraulic system of the mounted attachment or pump of the SS system.	Check the condition of the self-moving cuffs and replace, if necessary.
Increased oil heating during the operation of the system	
Insufficient quantity of oil in the tank.	Add oil to the tank to the upper mark of the oil meter
The oil pipelines are bent or rumped.	Eliminate the dents or replace the oil pipeline.
Unblocking of the parts of the stem valve of the distributor.	Replace stem valve.
The agricultural implement is not held in the transport position (After lifting to the transport position, the implement is lowered spontaneously)	
Oil leakage over sealing rings of the cylinder piston or rod;	Replace the sealing rings of the cylinder piston.
The slide valves or borings in the distributor body.	Replace the distributor.
During the power control, the tillage depth variation exceeds the agrotechnical norms, the engine rotational speed drops in case of overloads	
The correction rate cock is shut.	Increase the automatic correction rate by turning the handwheel counter-clockwise.
The central rod of the mounted attachment is set to the lower hole of the shackle.	Set the central rod to the upper hole of the shackle and, if the maximum tillage depth is insufficient – to the middle hole.
Maladjustment of the power sensor.	Adjust the power sensor and then the power rod (see section "Adjustments").
Maladjustment of the power rod.	Adjust the power rod (see section "Adjustments").
Loosening of the tightness of the split hubs of the levers on the intermediate shaft.	Tighten the bolts of the lever hubs on the intermediate shaft.
Distorted holes on the plough frog and frame connected by the toe bar, insufficient stiffness of the plough frame.	Repair the plough to ensure the frame stiffness and its connection with the frog.

TROUBLE, EXTERNAL MANIFESTATION	REMEDY
The governor handle fails to return by its own from the “lifting” position to the “transport neutral” one	
Jamming in the joints of the control handle with the power governor	Eliminate the jamming, clean the surfaces of the articulated joints from the corrosion traces; if necessary, apply a layer of lubricant.
The latch spring bolt on the control handle is over-tightened	Adjust the latch spring tension on the control handle.
Maladjustment of the governor control rod.	Adjust the rod length (see section “Adjustments”).
B. With hydraulic lift	
The unloaded mounted attachment is not lifted; when setting any handles of the distributor to the “lifting” or “lowering” position, no specific sound emitted by the pump under load	
Clogging of the safety valve of the tractor distributor.	Disassemble and wash the safety valve. Adjust the pressure maintained by the safety valve.
The unloaded mounted attachment is not lifted; when setting any handles of the distributor to the “lifting” or “lowering” position, a specific sound emitted by the pump under load is heard. After stopping the engine and moving the position handle to the foremost position and then to the rear position and starting the engine, the mounted attachment is lifted (the power handle shall be in the foremost position).	
Clogging the orifice in the overload valve.	Remove the regulator-distributor from the tractor, remove a bypass valve from it, wash the valve and clean off the valve orifice.
The unloaded mounted attachment is not lifted; when setting any handles of the distributor to the “lifting” or “lowering” position, a specific sound emitted by the pump under load is heard. After stopping the engine and moving the position handle to the foremost position and then to the rear position and starting the engine, the mounted attachment is not lifted (the power handle shall be in the foremost position).	
Ingress of foreign particles under the spool valve.	Remove the cover from the regulator-distributor, set the position handle to the foremost position. The spool valve lock ring shall rest against the body of the regulator-distributor. Move the position handle to the rear position. The spool valve shall move upwards to the distance of at least 7 mm. If not so, remove the regulator-distributor, clean it from foreign particles jammed between the edges of the spool valve and body.
The loaded mounted attachment is not lifted or is lifted too slowly	
The fault becomes apparent as oil in the hydraulic system is warmed up – the pump is faulty.	Check the capacity of the pump. If the pump efficiency is below 0.7, replace the pump.
The fault becomes apparent at any oil temperature – clogging of the overload valve.	Remove the regulator-distributor, take the bypass valve away and wash it and the regulator-distributor in diesel fuel.
The loaded mounted attachment is lifted slowly; after stopping the engine, the spontaneous mounted attachment lowering is noticeable by eye, the position corrections are frequent, the pressure “hanging-up” is possible	
Destruction of the rubber seals of the regulator-distributor.	Remove the regulator-distributor and replace rubber seals by new ones.

TROUBLE, EXTERNAL MANIFESTATION	REMEDY
The pump is not unloaded over the whole range of travel of the mounted attachment with load when employing the position method of adjustment on reaching the specified position by the mounted attachment	
In case of minor displacements of the position handle towards the lowering position, the pump is shortly unloaded, on stopping the engine the leak-proofness is normal	
<ul style="list-style-type: none"> Jamming or loss of sealing of the valve-accelerator. 	Remove the regulator-distributor; take away the bypass valve, disassemble and wash it. If necessary, hammer the valve ball to this seat.
The pump is not unloaded as the position handle is shifted towards the lowering position, on stopping the engine the leak-proofness is normal	
<ul style="list-style-type: none"> Loss of sealing of the pressure setting valve. 	Turn out on the top surface of the governor, remove the springs, hammer the valve ball to this seat and refit the parts.
ELECTRIC EQUIPMENT	
Storage battery has low charge	
Low level of controllable voltage.	Replace the generator voltage regulator.
Slipping of the generator driving belt.	Adjust the belt tension.
Increased transfer resistance between the storage battery terminals and wire lugs due to oxidation and loosening.	Clean the terminals, tighten and grease non-contact parts with technical petroleum jelly. Tighten the fastening of SB switch and the "ground" jumper.
Storage battery faulty.	Replace.
Storage battery "boils" and requires frequent adding of distilled water	
High level of the controllable voltage.	Replace the generator voltage regulator.
Storage battery faulty.	Replace.
Starter fails to go on and turn the engine crankshaft	
One of wire lugs at the storage battery is disconnected.	Tighten firmly the lugs on the SB terminals.
Heavy oxidation of wire lugs and terminals of the storage battery.	Clean battery terminals and wire lugs, grease their non-contact parts with technical petroleum jelly.
Engine start locking unit has operated or its switch is faulty.	Set gearbox lever to leftmost or replace the switch.
Low starter starting moment due to storage battery discharging.	Charge the battery to the norm.
Starter is faulty.	Remove the starter and have it repaired.
Generator does not develop full power	
Slipping of generator driving belt.	Adjust.
Generator is faulty.	Remove the generator and have it repaired.
Generator noise	
Slipping or excessive tension of fan belt.	Adjust.
Bearing wear.	Remove the generator and have it repaired.
The pilot lamp of the electric torch pre-heater	
Break in the electric torch pre-heater circuit.	Eliminate.
The electric torch pre-heater circuit components are faulty.	Replace.

TROUBLE, EXTERNAL MANIFESTATION	REMEDY
CAB HEATING AND VENTILATION UNIT	
Warm air does not enter the cab	
No water circulation through the heating unit.	The valve is shut off – open it. Hoses are clogged – clean them. Air or ice blockage in the heater hoses – clean them. Fan has failed – contact a qualified specialist.
High-humidity heated air goes into the cab	
Water leakage in the radiator and heating system joints. Hoses are damaged.	Eliminate.
AIR-CONDITIONER	
The electromagnetic clutch of the compressor (while turning the temperature regulator, no specific metallic click is heard)	1. The electric equipment is faulty. Check the serviceability of the block of pressure sensors using a tester or multimeter: there shall be no open circuit between the leads of the block of sensors (red and pink wires). Check the integrity of the connections of the electric circuits from the compressor clutch to the air-conditioner control panel. 2. Coolant leakage has occurred. Detect the place of the coolant leakage. Detection of the coolant leakage places, replacement of the hoses and components of the air-conditioner shall be performed by trained personnel with the use of special equipment.
The air-conditioner fan motor does not operate	The electric equipment is faulty. Check the integrity of the respective fuse (25A, see the electric diagram) in the fuse block F4 located in the instrument dashboard. Replace the blown fuse. Check the presence of voltage at the air-conditioner motor using a test lamp when the switch is set to the ON position and the storage battery is connected to the battery. If the electric circuits are in good order, but no voltage is applied to the air-conditioner, replace the switch.
When the air-conditioner is switched to the cooling mode, warm air is supplied to the cab	Destruction of the seal of the cock ПO-11 (or BC11). Replace the cock ПO-11 (or BC11)
Coolant leakage from the ventilation compartment of the cab	Rupture of the heater tubes (“unfreezing” of the heater due to incomplete drainage during the operation with water in the cold season of the year). Replace the climatic unit of the air-conditioner.
PNEUMATIC SYSTEM	
Insufficient air pressure in the tank, the pressure slowly grows and quickly drops when stopping the engine	
Air leakage in the system.	Eliminate.
The compressor is faulty.	Remove and send it to the shop.
Air pressure in the tank decreases quickly when stepping on the brake pedal	
The brake cock is faulty.	Remove and send it to the shop.
Increased oil ejection into the pneumatic system	
The compressor is faulty.	Remove and send it to the shop.
No air intake for inflating the tyres	
The air intake valve plunger is insufficiently sunk in the pressure regulator.	Screw on the connection hose nut fully on the connecting branch.
The pressure regulator has switched the compressor to idling.	Reduce the pressure in the tank by 1.5...2 kgf/cm ² .

TROUBLE, EXTERNAL MANIFESTATION	REMEDY
Trailer brakes operate inefficiently or are released slowly	
Maladjustment of the brake valve actuator.	Adjust.
Maladjustment of the brake valve.	Remove and send it to the shop.
Trailer brake system has failed.	Eliminate the fault.

TRANSPORTATION AND TOWING OF THE TRACTOR

The tractors shall be transported by railway transport, on trucks and their trailers as well as by towing and under its own power.

When transporting the tractors:

- Set the gearbox levers to the first gear;
- Apply the parking/reserve brake;
- Fasten the tractor to the platform with the wire $\varnothing 0.3-5$ mm, chains and guy lines.

When handling the tractors, use the hoist mechanisms with the lifting capacity of at least 10 tf.

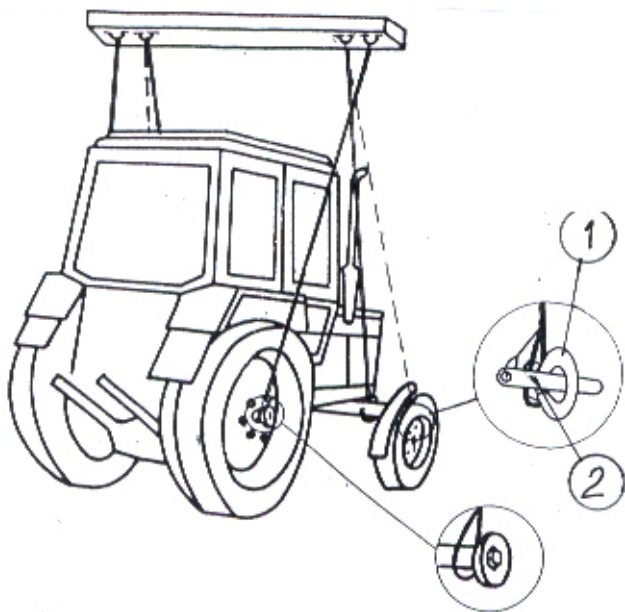

The ropes should be fastened at the front axle beam or eye-nut (1) and at the half-axles of the rear wheels as shown in the diagram below. When fastening the ropes by the eye-nut (1), draw the harness onto the eye-nut body and fix it by means of a stopper (2) through the eye of the eye-nut.

It is allowed to tow the tractor with inoperative HPS pump at the speed of not more than 10 km/h speed to a distance of up to 5 km.

The eye fastened to the front ballast weights and to the bracket of the weights is provided for fastening the towing rope. When towing the tractor, observe strictly road regulations.

Attention! When being lifted by the eye nuts, the tractor can move forward (backward) to the distance of up to 1.5 m.

It is forbidden to use tow clamp for lifting the tractor.

It is strictly forbidden to tow FDA tractor with the front wheels lifted.

STORAGE OF THE TRACTOR

Prior to putting the tractor for a long-term storage, perform the following operations:

- Clean the tractor.
- Clean the tractor inside and outside.
- Gun-grease all the lube points, namely.
- Drain oil from the engine crankcase, power train, tank of the hydraulic system and HPS, wheel reduction gears and final drive of the FDA and refill them with fresh clean oil.
- Drain fuel from the fuel tanks and pour about 5 l of preservation fuel.
- Start the engine and let it run for 5...10 minutes until the feeding system is filled.
- Lift the RHM rods to the top position and engage the fixing mechanism (RHM with an autonomous power cylinder).
- Remove the storage batteries, charge them and put for storage in a dry ventilated room with the temperature of 15..20°C. Check the condition of the batteries every month and recharge them as necessary.
- Lift the front and rear axles of the tractor by means of jacks and put the tractor onto the stands for unloading the tyres. Reduce the pressure in the tyres down to 70% of the normal value.
- Drain the cooling fluid from the engine cooling system and the cab-heating one.
- Preserve the plunger of the hydraulic steering cylinder or turn the front wheels in such a way that the rod would be in the retracted position.

- Loosen the tension of the generator and fan belts.
- Put a jacket on the exhaust pipe hole.
- Crank the engine crankshaft to several revolutions at least once a month.

To remove the tractor from the long-term storage, perform the following operations:

- Remove the tractor from stands and bring the pressure in tyres to its normal value.
- Fill up fuel tanks.
- Check the level of cooling fluid and oil in all the vessels to be filled.
- Re-install fully charged storage batteries
- Remove the jacket from the exhaust pipe.
- Start the engine and carry out the functional checks on all the tractor instruments, controls and systems.
- Check the operation of the lighting and audible signalling devices.
- Run the tractor without load to make sure that it operates properly.

IMPORTANT! The operations for putting the tractor for storage and removing the same from the storage in the part related to the engine shall be performed according to the operating manuals provided by the engine manufacturer.

APPENDIX A. ELECTRIC EQUIPMENT

List of the components of the electric connection diagram of the tractor

Designation	Description	Q-ty
A1	Stereo cassette radio	1
A2	Glow plugs	4
A3	Control panel	1
A4	Air-conditioner	1
A4.1	Air processing unit	1
A4.1.1	Air output temperature control	1
A4.2	Compressor and condenser unit	1
A4.3	Pressure sensors unit	1
M6	Fan motor	1
S1	Fan modes switch	1
YC	Electromagnetic clutch of the compressor	1
A5	Electric torch preheater	1
BA1,BA2	Speaker	2
BK1	Temperature indicator sensor	1
BN1	Fuel level indicator sensor	1
BP1	Engine oil pressure gauge	1
BP2	Air pressure sensor	1
BV1,BV2	Rotational speed sensor	2
E1, E2	Road headlight	2
E3, E4, E5, E6, E8, E9	Working headlight	6
E7	Cab lighting lamp	1
E10	Number plate light	1
EL1, EL2	Lamp АКГ12-60+55-1	2
EL3,EL7,EL8, EL13,EL15, EL16,EL25	Lamp АКГ12-55-1	7
EL4 ...EL6, EL9,EL10, EL20,EL21	Lamp A12-5	7
EL11,EL14, EL17,EL19, EL22,EL24	Lamp A12-21-3	7
EL18,EL23	Lamp A12-10	2
F1...F4	Fuse boxes	4
FU1	Fuse	1
FU2, FU3	Fuse link 25 A	2

Designation	Description	Q-ty
G1	Alternator 14 V, 1150 W	1
GB1,GB2	Storage battery 12 V, 88 A-h.	2
HA1	Horn	1
HA2	Signalling relay	1
HG1,HG2	Pilot lamp block	2
HL1...HL3	Road train sign light	3
HL4,HL5	Front light	2
HL6,HL7	Rear light	2
HL8	Signalling beacon	1
K1	Relay glow plug	1
K2	Instrumentation supply relay	1
K3...K6, K8...K10	Normally opened relay 30 A	7
K4	Normally closed relay 20 A	1
K7	Starter solenoid switch	1
KH1	Parking brake pilot lamp flasher	1
KH2	Turn indicator flasher	1
KT1	Glow plug block	1
KT2	Preheater control unit	1
M1	Fan motor(90Вт)	1
M2	Pantographic-type windscreen wiper	1
M3	Starter 24 V, 4 kW	1
	Starter 12 V, до 3 kW	1
	Starter 12 V, 2,7 kW	1
M4	Electric windscreen washer	1
M5	Windscreen wiper	1
M7	Fan motor (120 W)	1
P2	Combination meter КП-5	1
P3	Tachospeedometer	1
QS1	Remote battery disconnect switch 24 V	1
QS2	Remote battery disconnect switch 12 V	1
QS3	Manual battery disconnect switch 12 V	1
QS4	Manual battery disconnect switch 24 V	1
R1	Additional resistor of the fan motor	1

Continuation of the Table

Designation	Description	Q-ty
SA1	Road train sign switch	1
SA2, SA3,SA11	Working lights switch	3
SA4	Fan switch	1
SA5	Windscreen wiper switch	1
SA6	Starter switch with the start interlocking	1
SA7	Combined switch	1
SA8	Battery disconnect switch	1
SA9	Windscreen washer switch	1
SA10	Upper/lower beam switch	1
SA12	Start interlocking switch	1
SA13	Signalling beacon switch	1
SA14	Starting aid switch	1
SB1	Fault signalling switch	1
SB2	Stop-light switch	1
SB3	Parking brake lamp switch	1
SK1	Emergency temperature sensor	1
SP1	Air cleaner clogging sensor	1
SP2	Emergency air pressure sensor	1
SP3	Emergency oil pressure sensor	1
UZ1	Voltage converter	1
XS12.1 XS12.2	Socket ШС32П12Г-M-7	2
XS12.3	Socket ШС32ПК12Г-MT-7	1
XS15.1	Socket ШС36У15Г-M-6	1
XP12.1 XP12.2	Plug ШС32ПК12Ш-MT-7	2
XP12.3	Plug ШС32П12Ш-M-7	1
XP15.1	Plug ШС36ПК15Ш-MT-6	1
XA9.1	Socket for agricultural implements	1
XT1	Branching unit	1
XT2.1,XT2.2	Two-contact junction panel	2
XT3.1,XT3.2	Three-contact junction panel	2
WA1	Antenna	1

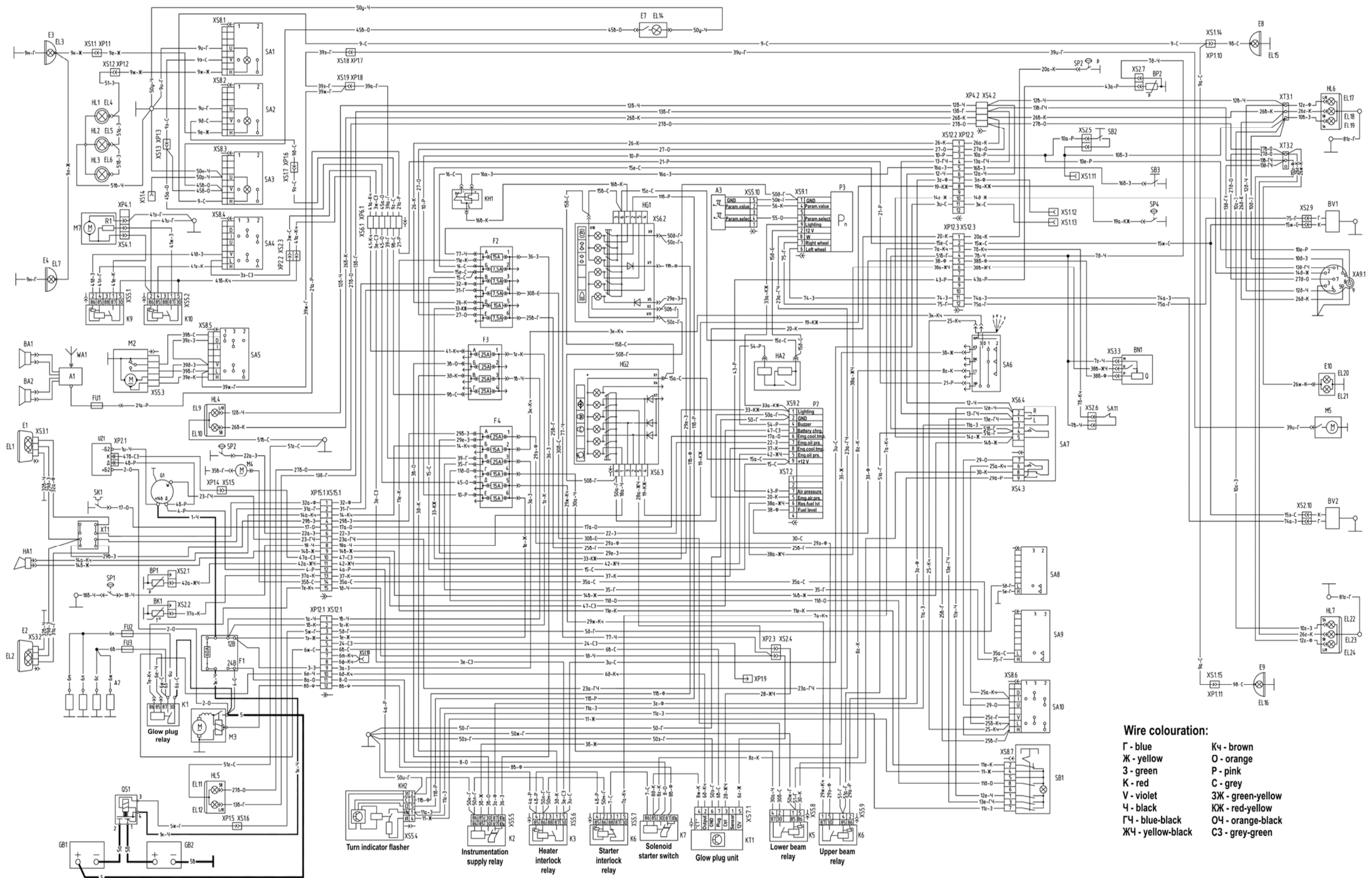

- Wire colouration:**
- | | |
|-------------------|-------------------|
| Г - blue | Кч - brown |
| Ж - yellow | О - orange |
| З - green | Р - pink |
| К - red | С - grey |
| У - violet | ЗЖ - green-yellow |
| Ч - black | КЖ - red-yellow |
| ГЧ - blue-black | ОЧ - orange-black |
| ЖЧ - yellow-black | СЗ - grey-green |

Electric connection diagram of the tractor

Variants of electric equipment of the tractors

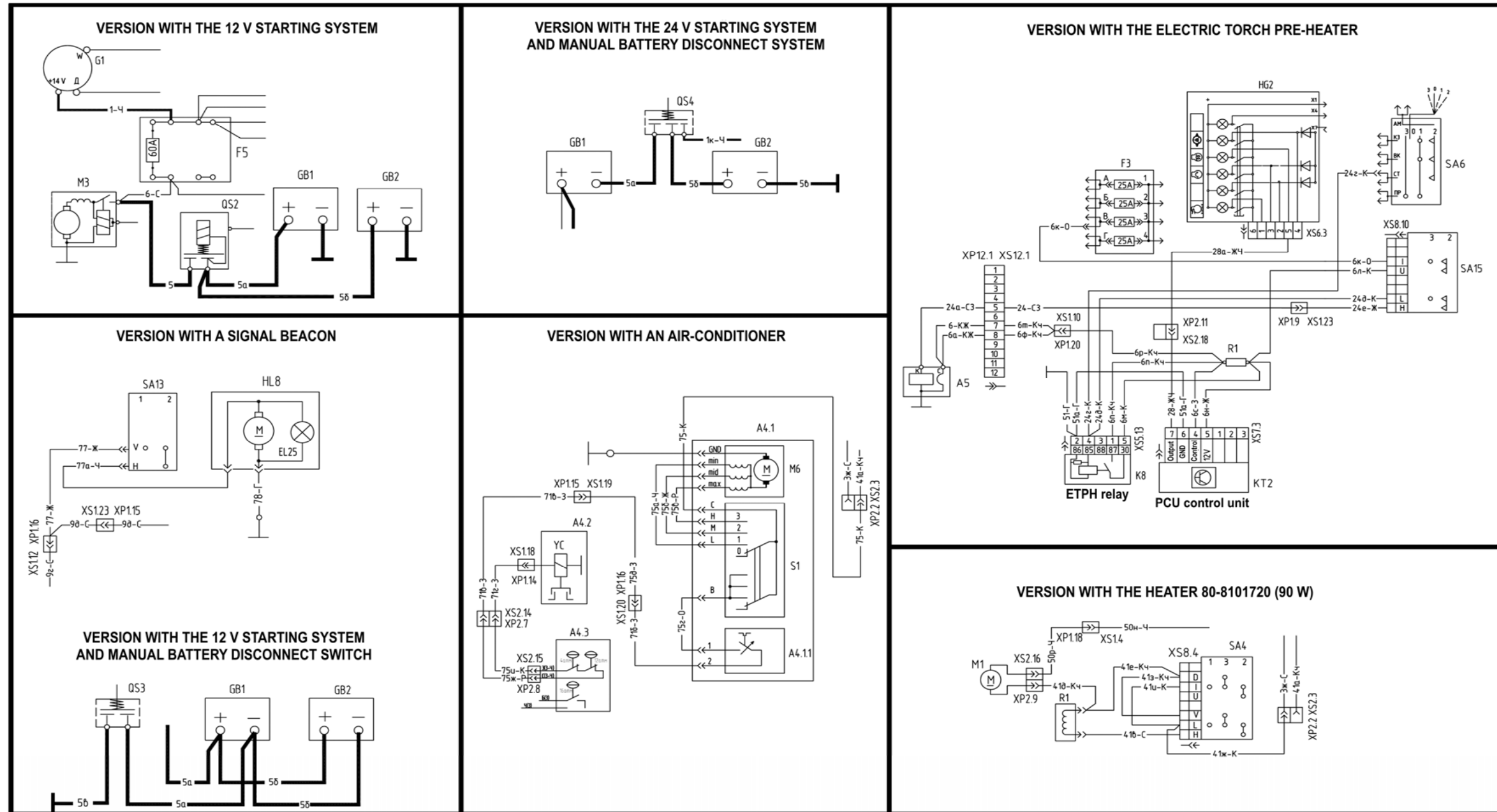

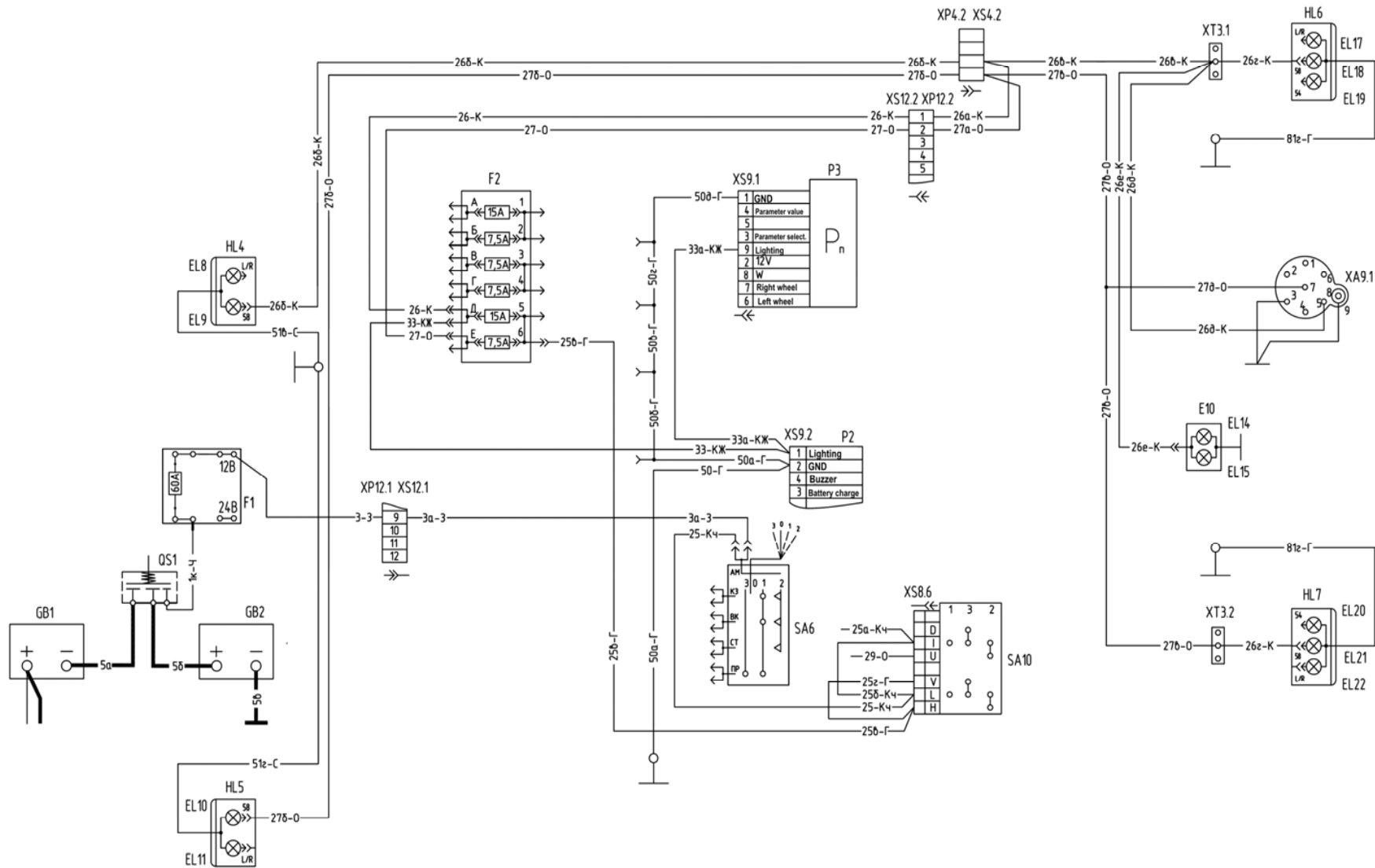

Connection diagram of the clearance lamps, number plate lights and instruments

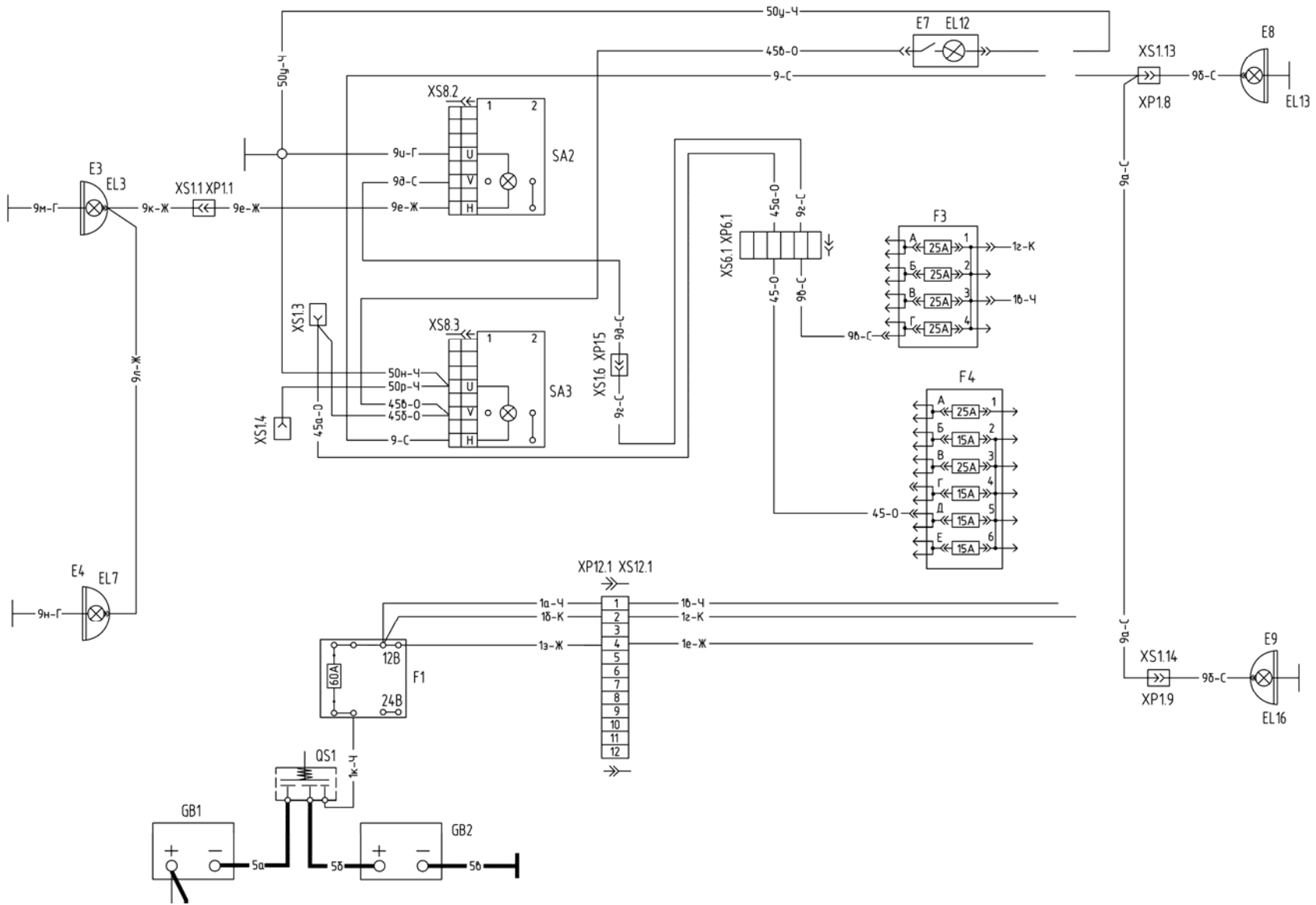

Connection diagram of the front and rear working lights and cab lighting lamp

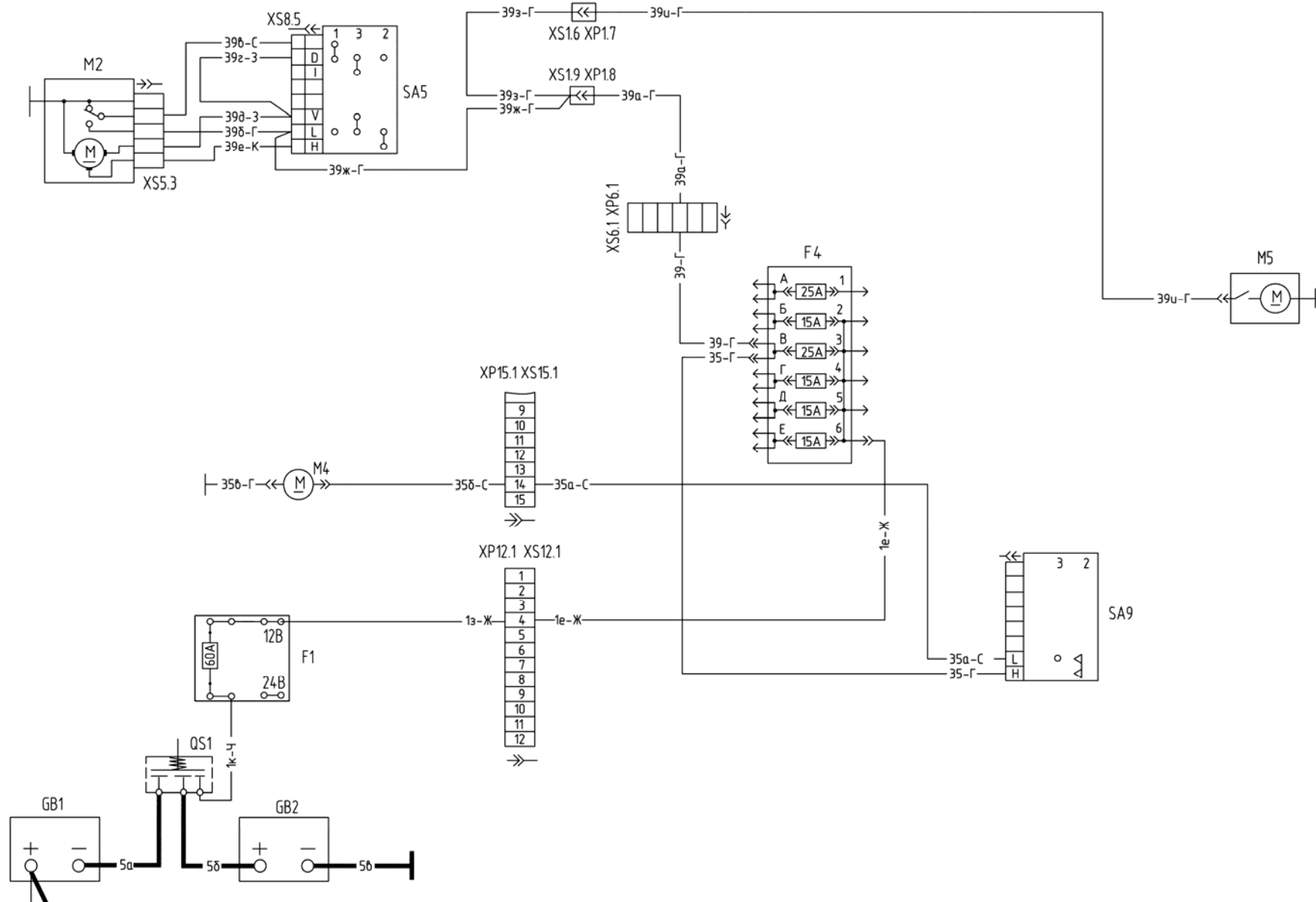

Connection diagram of the wind- and rear screen wipers and windscreen washer

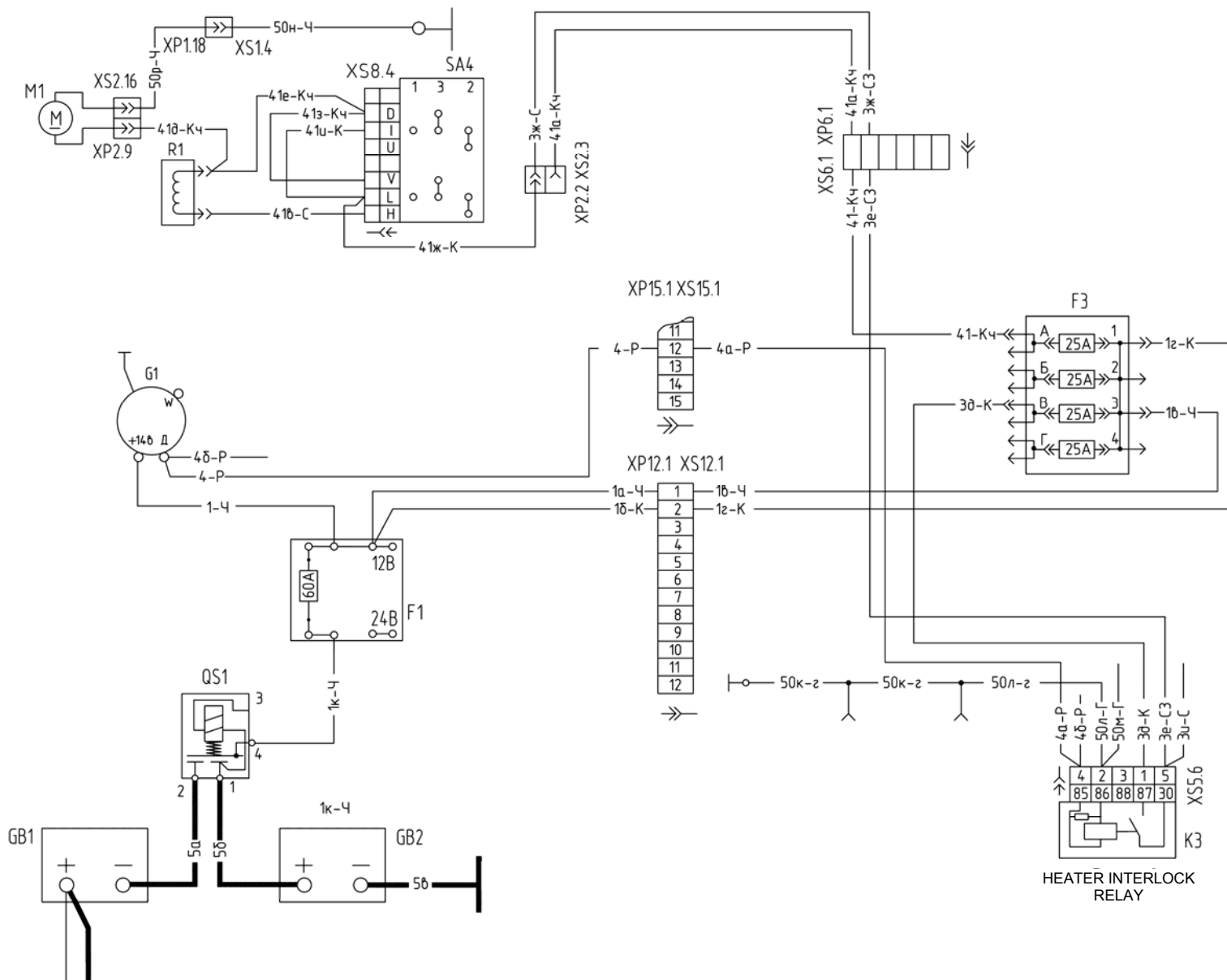

Connection diagram of the cab heater and fan with the fan motor power of 90 W

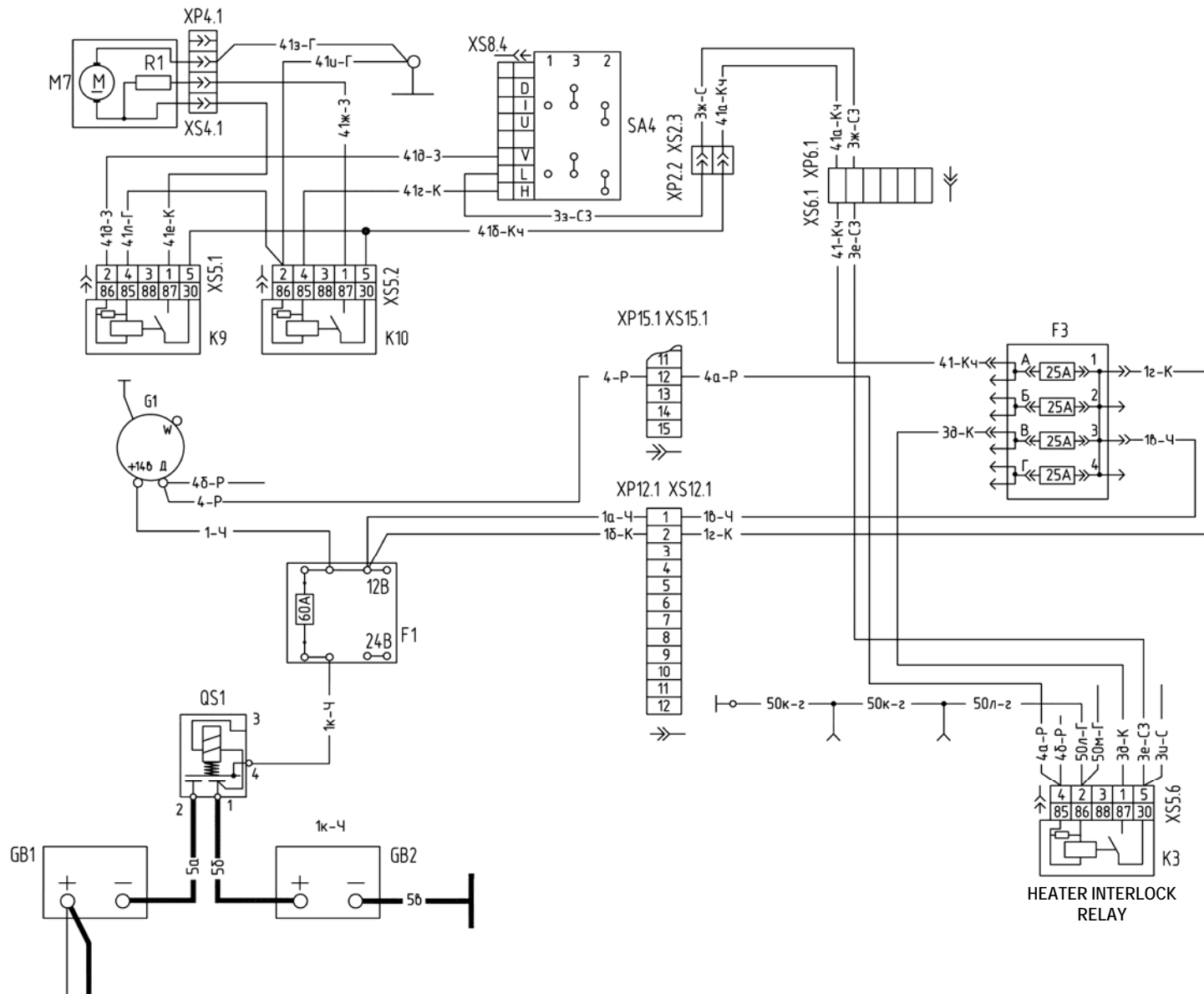

Connection diagram of the cab heater and fan with the fan motor power of 120 W

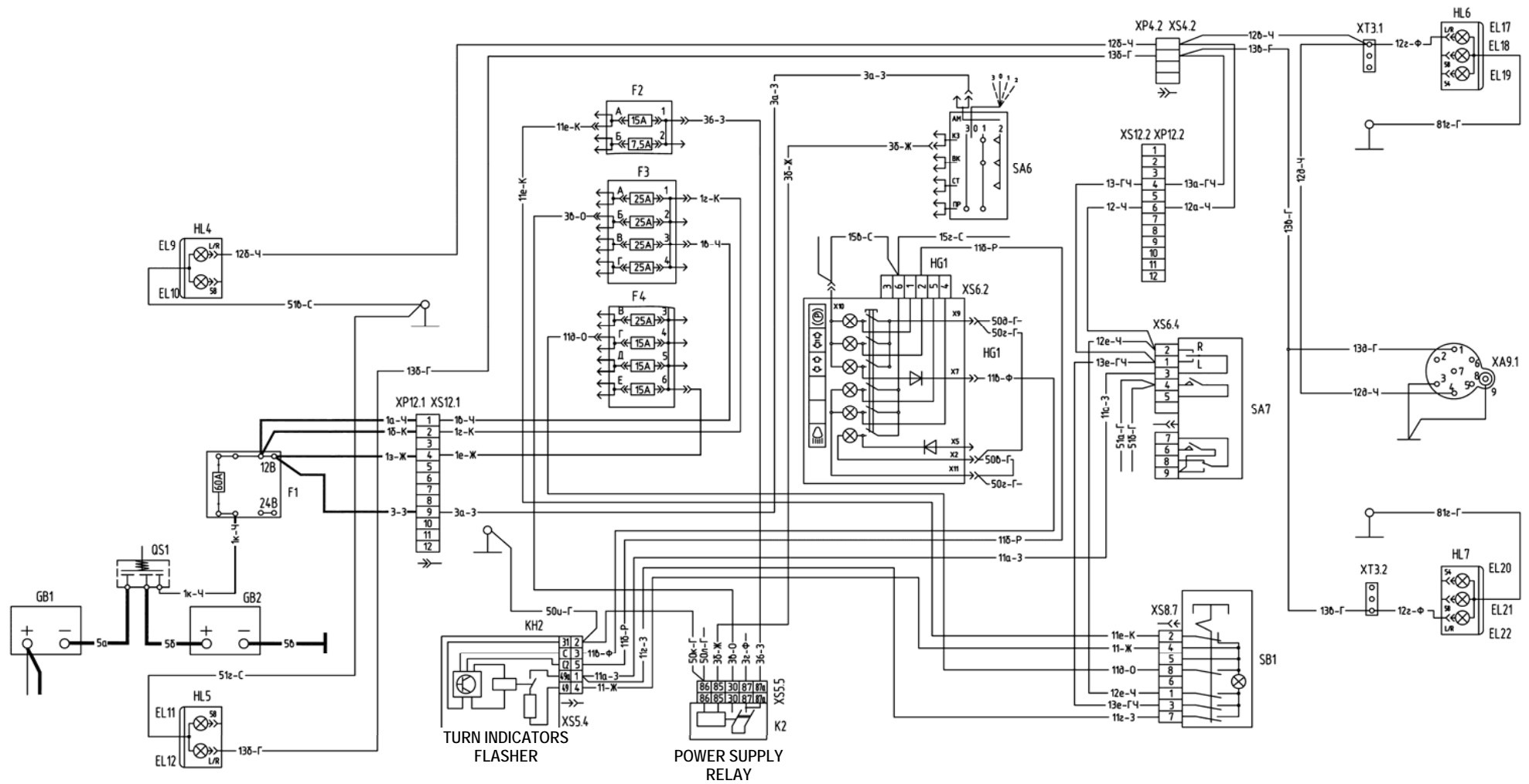
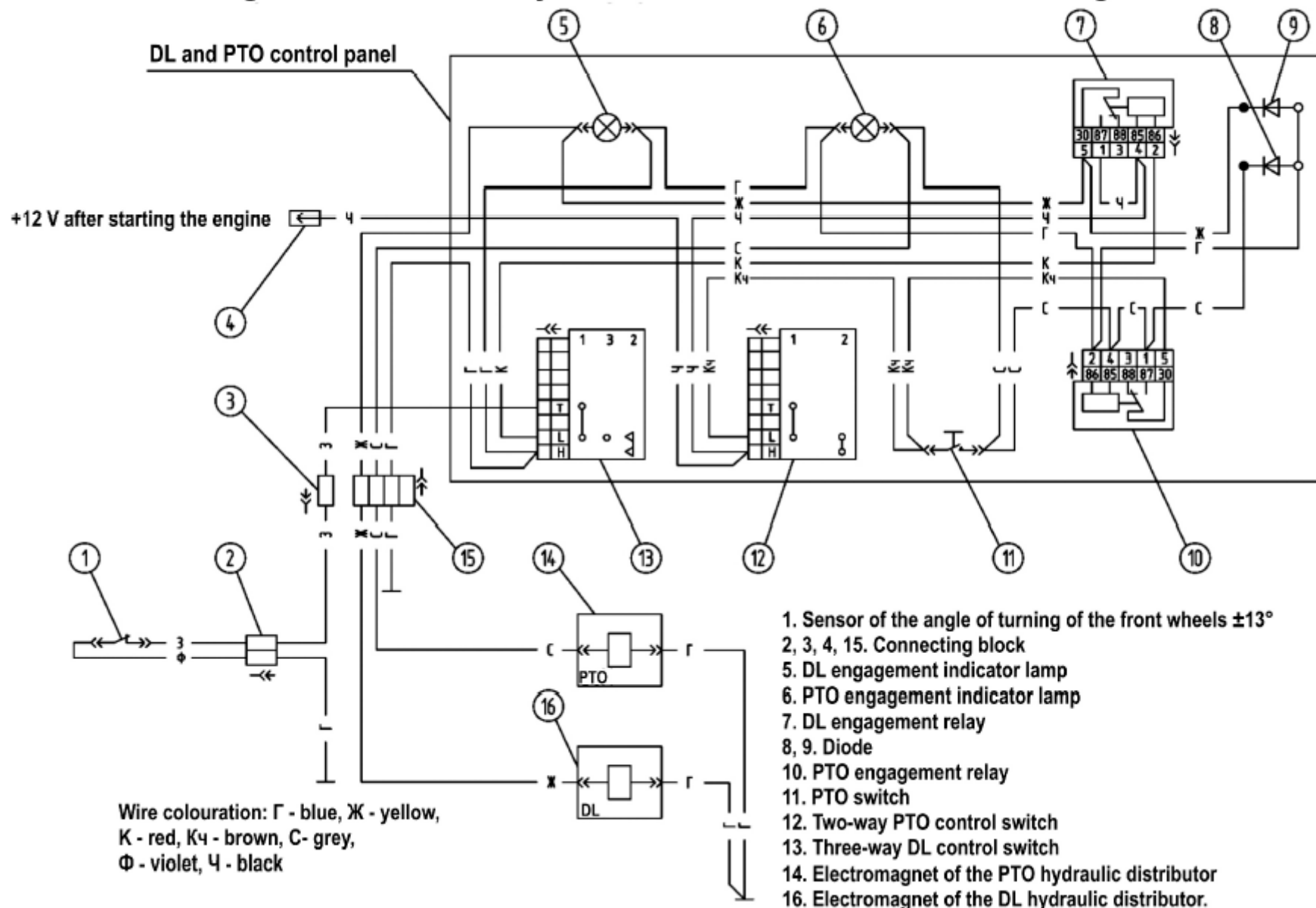

Diagram of the turn indicators and fault signalling

Electric diagram of the control system of the rear axle differential locking and PTO



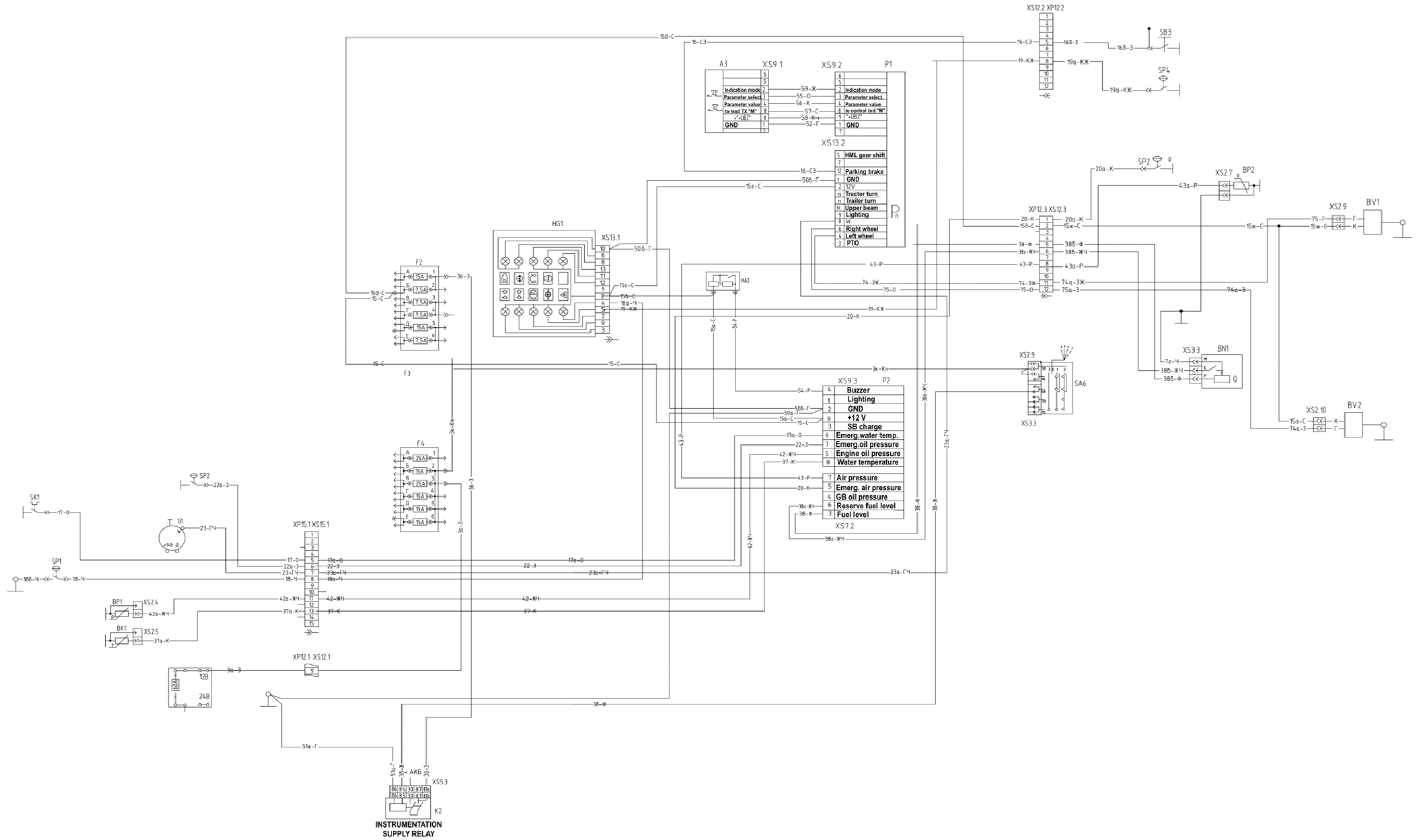

Diagram of the instrumentation dashboard 826-3805010

1. Power supply system

The Belarus tractors are equipped with the following power supply systems:

- On-board power system with the rated voltage of 12 V and starting system with the voltage of 12 V and two storage batteries connected in parallel each with the voltage of 12 V (Fig. 2, variants 1, 3 and Fig. 3);
- On-board power system with the rated voltage of 12 V and starting system with the voltage of 24 V and two storage batteries each with the voltage of 12 V interconnected in parallel by means of the circuit breaker (Fig. 2, variant 2 and Fig. 4).

Fig. 2 shows the schematic of the power supply system with four versions of connection of the storage battery and ground switches (circuit breakers):

- **Basic version – starting system 24 V.** The storage batteries GB1 and GB2 are interconnected in series through a remotely controlled SB circuit breaker QS1.

- **Variant 1 – starting system 12 V.**

The storage batteries GB1 and GB2 are interconnected in parallel and connected to the circuitry through a remotely controlled SB circuit breaker QS2.

- **Variant 2 – starting system 24 V.**

The storage batteries GB1 and GB2 are interconnected in series through the manually controlled battery disconnect switch QS4.

- **Variant 3 – starting system 12 V.**

AKB GB1 and GB2 are interconnected in parallel and connected to the circuitry through the manually controlled battery disconnect switch QS3.

The voltage indicator used on the tractors has a zonal scale making it possible to get the information on the condition of the power supply system of the tractor:

1. After setting the battery disconnect switch to the on position before starting the engine (when the consumers are not energized), the voltage indicator pointer

is in the yellow zone (12-13.2 V) and indicated the electromotive force of the storage battery and degree of its charge:
12.7 V: 100% of charge;

12 V: 50% of the charge and less.

2. On starting the engine, the voltage indicator pointer moves to the left red zone (10-12 V). During the operation of the starter, the voltage drop down to 6 V is possible.

3. After starting the engine, the indicator pointer indicated the voltage in the on-board power system generated by the alternator.

In the normal operation mode, the pointer shall be in the green zone (13.2-15.2 V). The short-time pointer movement to the yellow zone (12-13.2 V) is allowed during the engine running at low rotational speed and connection of the consumers, the total power of which exceeds the alternator output power at this speed mode.

In the remaining operating modes, if the voltmeter pointer is

- to the left from the green zone, the alternator or integral voltage adjuster (IVA) are faulty or open circuit;
- to the right from the green zone, the IVA is faulty.

1.1. Troubleshooting of the power supply system

A. No voltage in the on-board power system after setting the battery disconnect switch QS1 to the on position:

- Check the intactness of the fuse F1;
- Check the contacts at the place of connection of the wires to the SB terminals;
- Check the integrity of the circuit from the storage battery to the fuse.

B. No battery charging after starting the engine:

- Check the condition of the alternator driving belt and voltage regulation;
- Check the intactness of the fuse F1;
- Using a voltage indicator, check the controllable voltage of the alternator (Fig. 1), which shall be 14.2 – 15.2 V;
- Check the reliability of the contacts in the circuit from the alternator to the voltage.

Note: The check shall be performed at the rated rotational speed of the engine and working headlights on.

C. The storage batteries are systematically undercharged:

- Check the value of the controllable voltage (Fig. 1), and, if it is below the allowable value, replace the IVA;
- Check the technical condition of the storage battery;

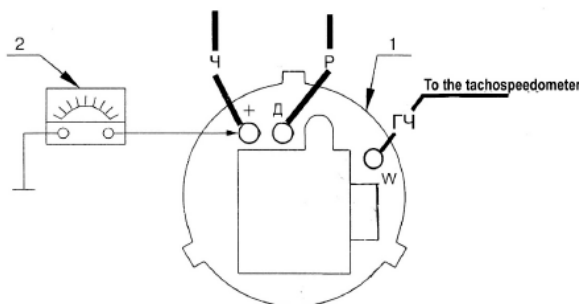

Fig. 1. Checking the controllable voltage value: 1 – alternator G1; 2 – voltage indicator.

- Check the reliability of the contacts in the connections of the terminals of the wires from the alternator to the storage battery having excluded the possible increase of the resistance at the terminals due to loosening of their fastening or oxidization.

D. On the tractors with the power supply system with the voltage of 12/24 V (Fig. 2) and voltage converter UZ1, the left storage battery is not charged;

- Check the integrity of the fuse and reliability of its fastening to the voltage converter body ПН-191-375901 (ПН 14/28 V 8 A); if the fuse (20 A) is blown off, the pilot lamp of the voltmeter in the combined meter lights up;
- Check the fastening the wires to the terminals.

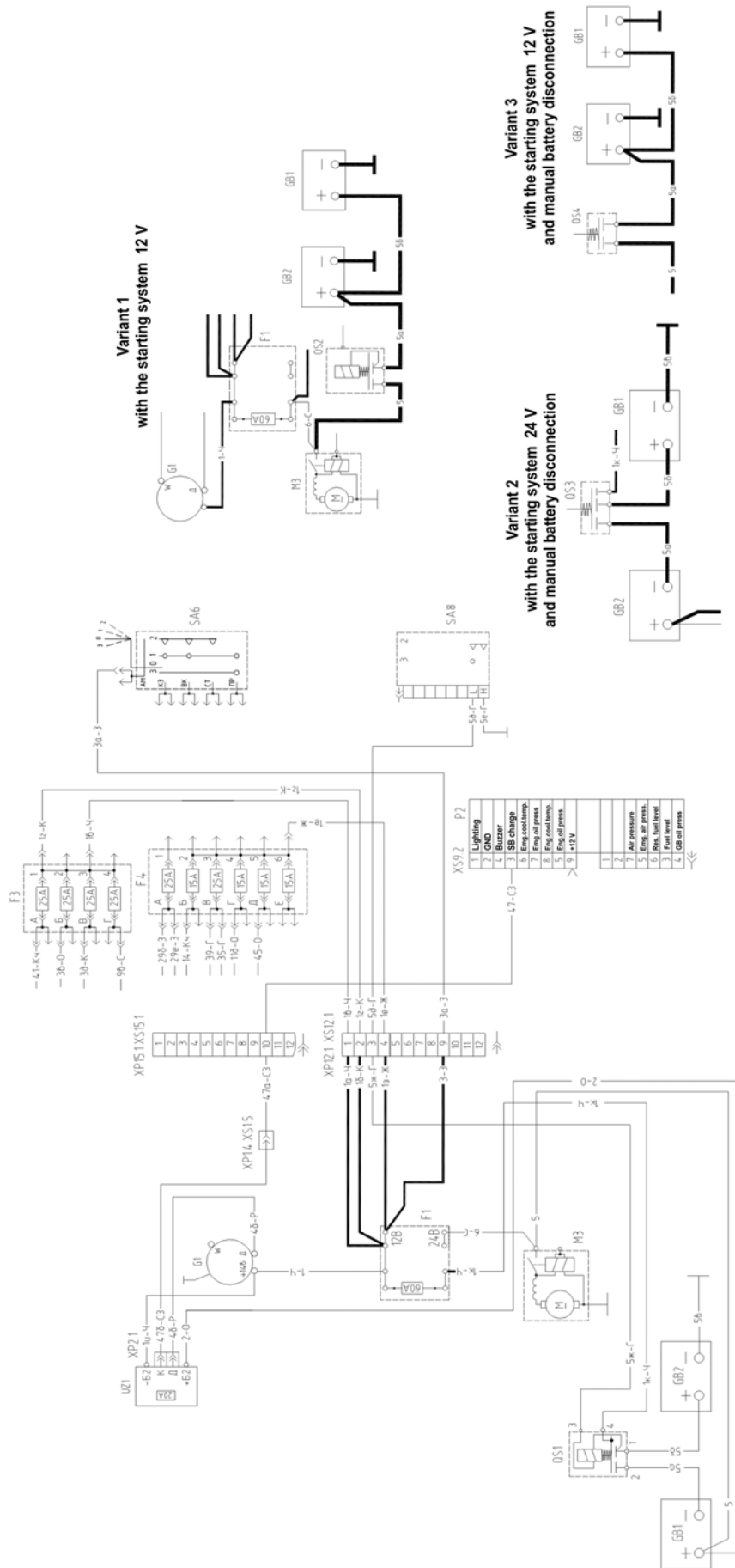

Fig. 2. Power supply system of the tractors

2. Engine starting system

The engine starting system circuitry has the following differences depending on the supply voltage of the starter:

A. Starter M3 with the rated voltage of 12 V (Fig.3):

- The power supply of 12 V is applied to the starter from the two interconnected batteries “GB1” and “GB2”, each 12 V;
 - The voltage is applied to the solenoid starter switch for energizing the starter from the terminal “87” of the solenoid starter switch “K7”.

B. Starter M3 with the rated voltage of 24 V (Fig. 4):

- The voltage of 24 V is applied to the starter from the two storage batteries “GB1” and “GB2” each having the voltage of 12 V connected in series;
- The voltage is applied to the solenoid starter switch for energizing the starter from the terminal “87” of the solenoid starter switch “K7”.

The starter “M3” supplied with the voltage of 12 V and 24 V is switched on by turning the starter and instrumentation switch “SA6” to the “CT” position.

For the instrumentation dashboard 80-3805010-Д1:

The relay “K6” performs the function of blocking against restart (starter blocking) when the engine is running.

The starter blocking relay operates to de-energize the starter solenoid switch “K7” that causes the switching-off of the starter.

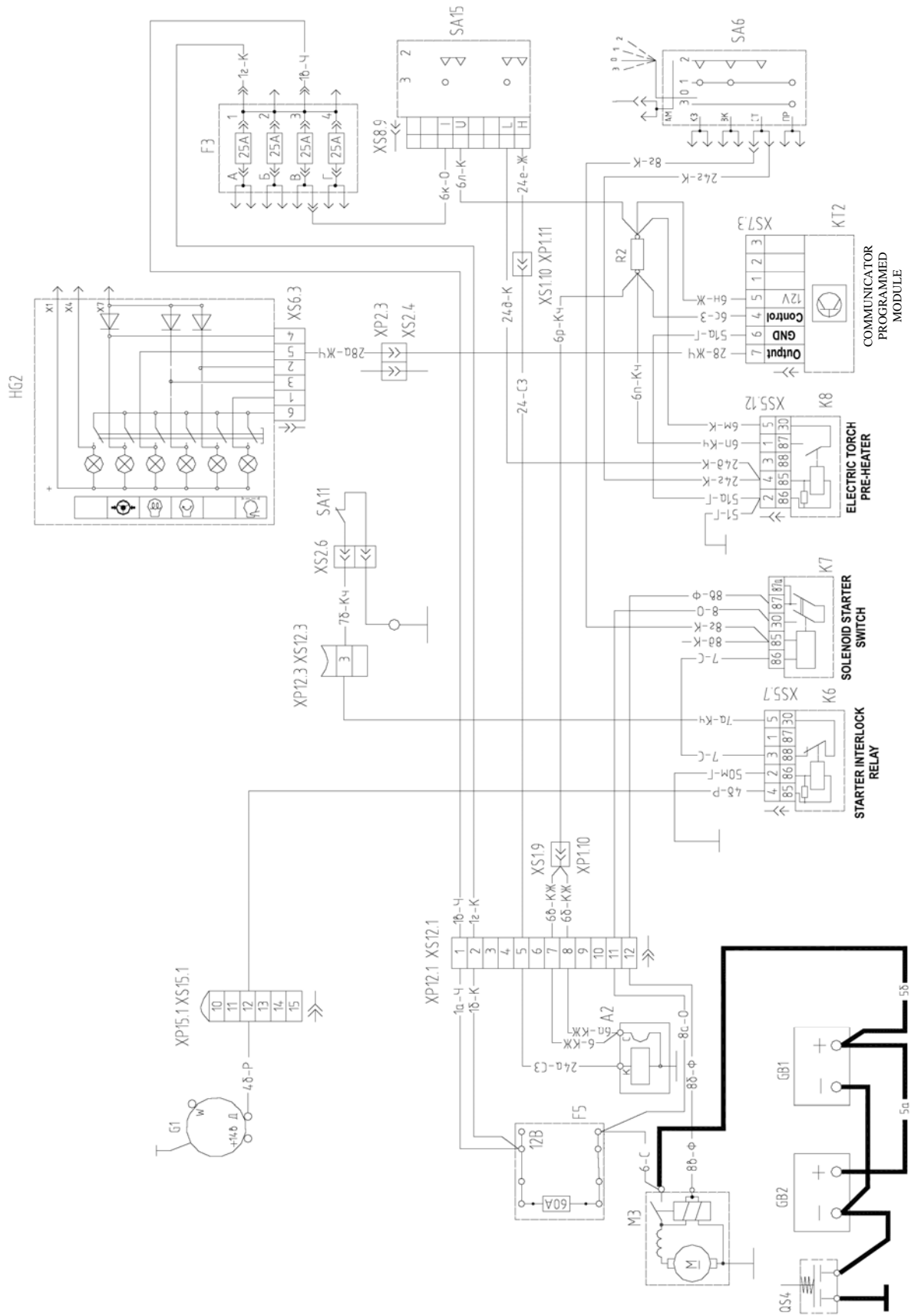

Fig.3. Starting system 12 V, starting aid system (electric torch pre-heater).

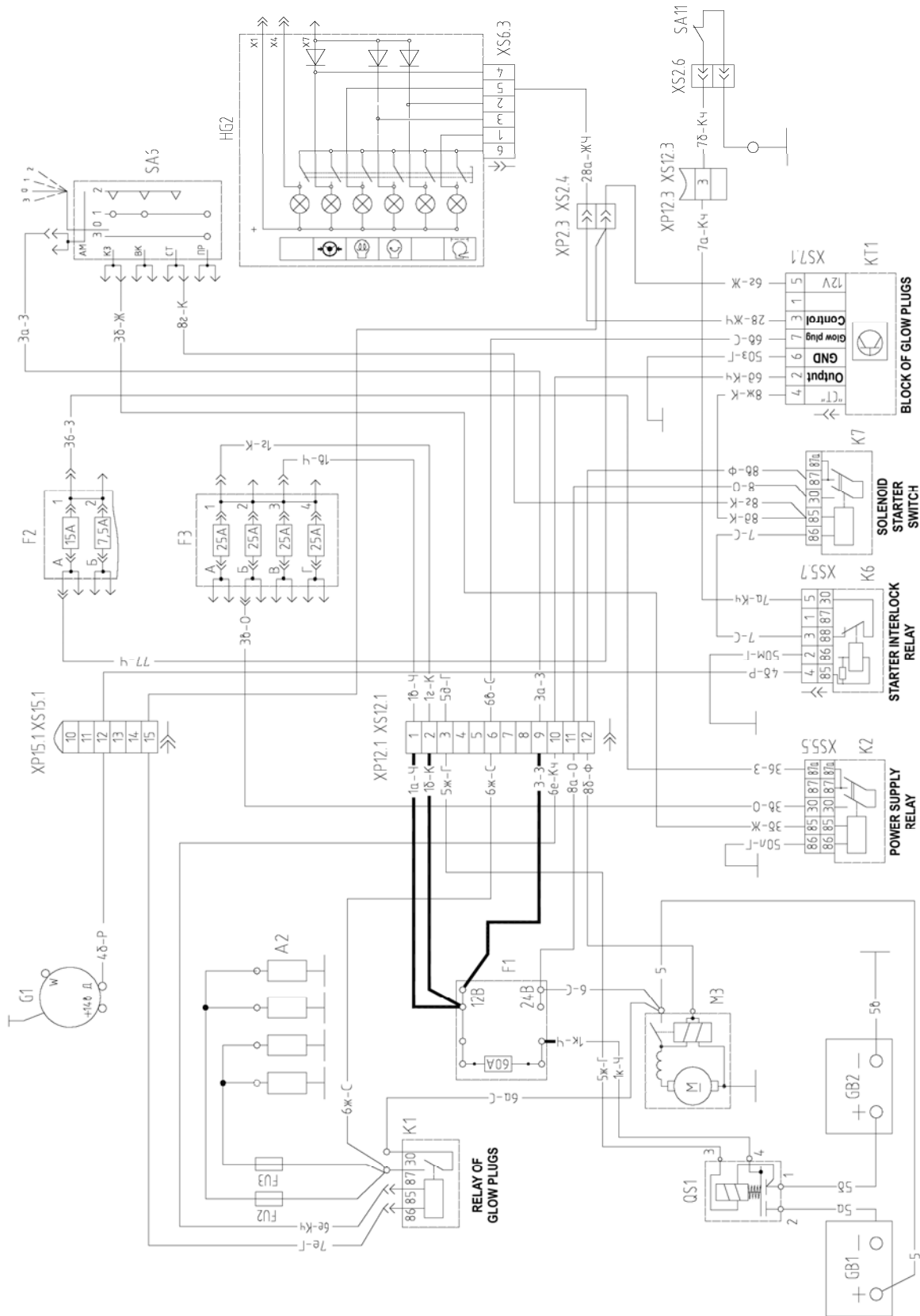

Fig. 4. Starting system 24 V, starting aid system (glow plugs)

2.1. Troubleshooting in the starting system

A. Too low starting rotational speed of the starter M3:

a) Eliminate the possible loosening of the fastening or oxidization of the power system circuit:

- on the storage batteries;
- on the battery disconnect switch;
- of the battery connection jumper between the cab and the tractor body;
- on the starter terminals and fasteners.

b) Check the degree of charging of the storage batteries.

If the rotational speed of the starter has not changed after performing the said operations, perform the maintenance or repair of the starter.

B. The solenoid starter switch operates (the sound of its operation is heard), but the engine is not cranked:

a) if at that time the pilot lamps on the tractor's instrumentation dashboard function normally:

- check and clean, if necessary, the contacts of the solenoid starter switch, adjust the drive mechanism;
- check the condition of the brush and commutator assembly of the starter;
- repair the starter;

b) if at that time the pilot lamps on the tractor's instrumentation dashboard become considerably dimmer:

- perform the operations specified above in the item "A.a".
- c) if at that time the solenoid starter switch operates cyclically:

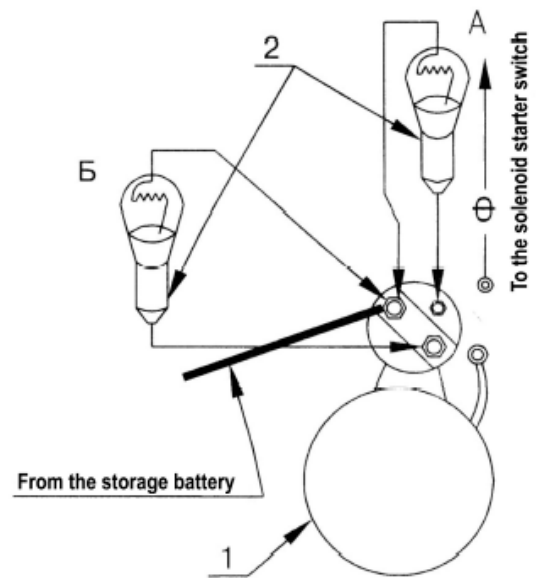

Fig.5. Checking the integrity of the windings of the solenoid starter switch "M3".

1 – Starter;

2 – Pilot lamp;

"A" – of the hold-in winding;

"B" – of the pull-in and hold-in windings.

- check the integrity of the hold-in winding of the solenoid starter switch and integrity of the termination of its leads:

1) disconnect the following wires from the terminals of the solenoid starter switch:

- wire "Φ" from the terminal "M5";
- bus "+" from the power terminal to the starter motor.

2) set the ground switch and connect the test lamp to the terminals of the solenoid starter switch as shown in Fig. 5. If the windings are intact, the lamp shall be lit dimly.

C. The starter cannot be switched on:**a) Check the operability of the starter**

- check one wire of the test lamp to the ground and another wire in turn:
 - 1) to the power terminal of the starter (Fig. 6);
 - 2) to the terminal of the solenoid starter switch (having turned the starter switch key to the second position) (Fig. 6);

NOTE. For the starting system with the voltage of 24 V (Fig. 4) use the test lamp rated at 24 V (A24-21).

- 1) If the test lamp lights up in both cases, test and repair the starter;
- 2) if the test lamp does not light up on both cases or lights up in one case, repair the electric circuits of power supply and control of the start (see below).

b) Check the operation of the starter interlock switch “SA11” with the gearbox reduction gear engaged (Fig. 7).

The NO interlock switch with the ball pusher is located on the gearbox control mechanism and integrated in the circuit between the winding of the starter solenoid switch “K7” and “ground”.

Operation of the switch

On engaging the gearbox reduction gear, the switch contacts are opened under the action of the control shaft that prevents the engine from being started.

When the reduction gear lever is set to the neutral position or when the gearbox lever is set to the “Reduction gear” (Редуктор) position, the shaft lug closes the switch contacts, which provides connection to the body for the starter solenoid switch and possibility of starting the engine.

To check the switch operation, proceed as follows:

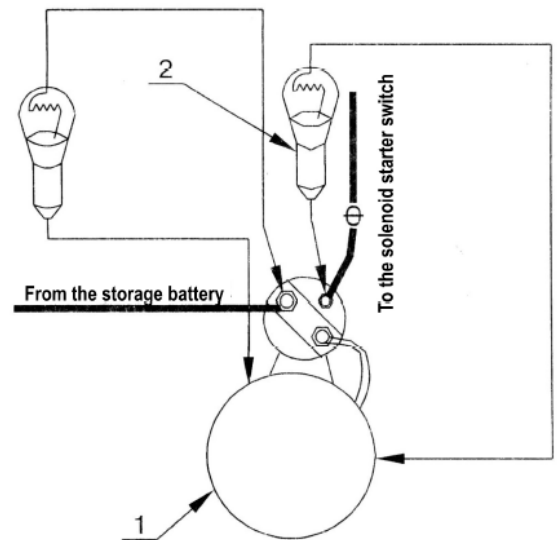

Fig. 6. Checking the operability of the starter “M3”: 1 – starter; 2 – test lamp.

- connect one wire of the test lamp to the switch terminal with the wire K4 and stretch out another one to the “+” terminal of the regular storage battery (Fig. 7);
- set the battery disconnect switch to the ON position;
- set the gearbox lever to the neutral position: the switch contacts shall be closed and the test lamp shall be lit;
- set the gearbox lever to the ON position: the switch contacts shall be opened and the test lamp shall not be lit.

Note: The test lamp shall be energized from the power terminal of the starter.

D. Check the condition of the starting control circuits and instruments:

- a) Remove the side pieces of the dashboard;
- b) Check the operability of the starter switch (SA6) by connecting one wire of the test lamp to the body and another wire to the switch terminals in turn (Fig.8 and 9):

“+” – wire “K4”;

“CT” or “30” – wire “K” (the key shall be in the position “II”);

In both cases, the test lamp shall be lit.

Starter switch key position:

“O” – OFF; “I” – the measuring instrumentation, pilot lamp blocks, flashers of the turn indicators and parking brake pilot lamp, radio receiver, key of the electric torch pre-heater (or glow plugs) of the engine starting aid system (terminals “K3”, “ПР”, “BK” or “58”, “19”, “15”) are energized;

“II” – the consumers of the position “I” (except for the radio receiver, “ПР” or “15”), starter solenoid switch and winding of the electric torch pre-heater through the button of the electric torch pre-heater (when being released, the key returns to the position I) (terminals “K3”, “BK”, “CT” or “58”, “15”) are energized;

“III” – the radio receiver is energized (terminal “ПР” or “15”).

- c) Check the integrity of the circuits and application of the voltage to the terminals of the starter solenoid switch (K7) (Fig. 10):

- check one wire of the test lamp to the body and another one in turn to

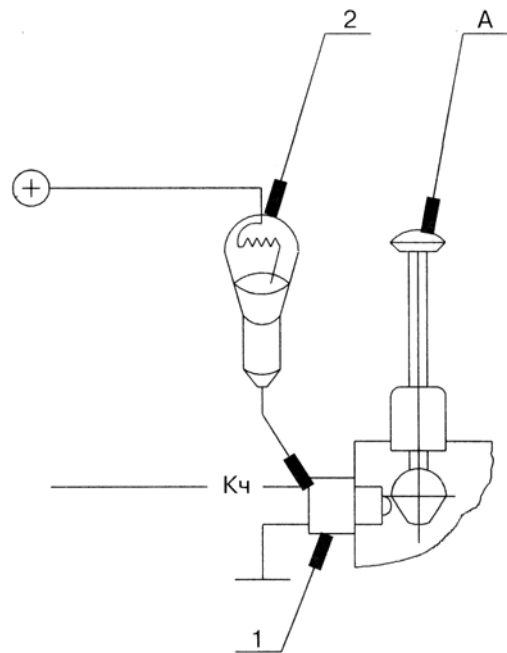

Fig. 7. Checking the operation of the starter interlock switch.
1 – interlock switch; 2 – test lamp;
2 – “A” is the neutral position of the gearbox lever.

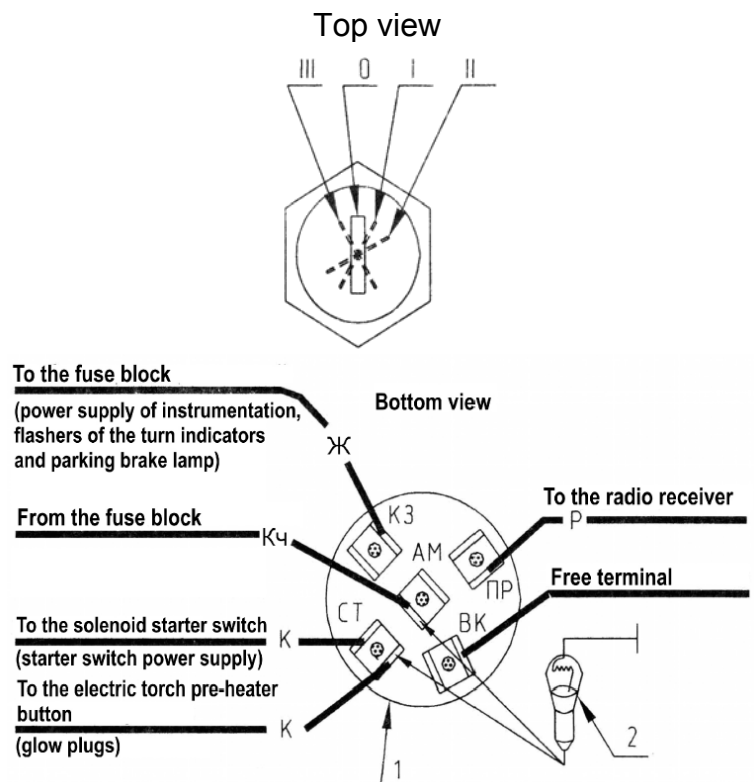

Fig.8. Checking the operability of the starter switch (SA6). For the instrumentation dashboard 80-3805010-Д1.
1 – Starter switch;
2 – Test lamp.

the relay terminals:

- "Б" or "30" – wire O;
- "К" or "85" – wire K having turned the key to the "II" position.

In both cases, the test lamp shall be lit.

d) check the integrity of the circuit from the starter solenoid switch (K7) to the solenoid starter switch:

ATTENTION! Set the gearbox control lever to the reduction gear position.

- bridge the terminals "30" and "87" of the starter solenoid switch K7 using an additional wire. The starter shall be energized and the engine shall be started (while bypassing the starting control and interlock circuits).

e) Check the operability of the starter solenoid switch "K7":

- connect the terminal "86" of the starter solenoid switch (of the wire C) to the tractor body (when doing this, the circuits for interlocking the starter depending on the position of the gearbox lever position);
- turn the starter key switch "SA6" to the "II" position; the starter solenoid switch shall operate and, respectively, the diesel shall be started.

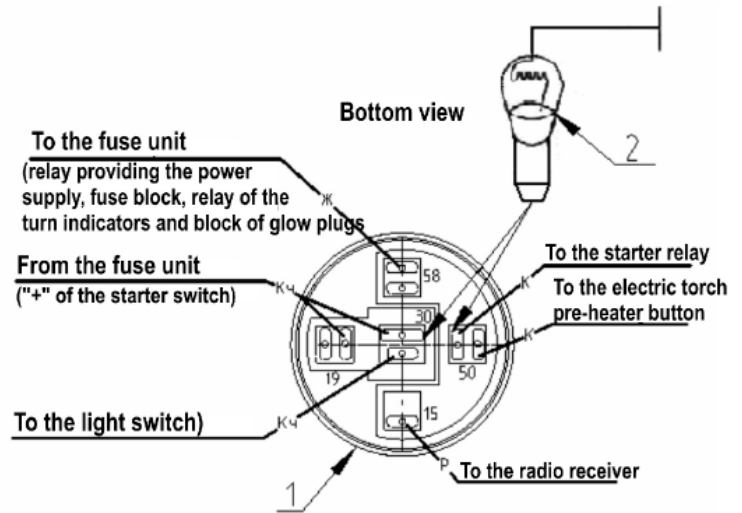

Fig. 9. Checking the operability of the starter switch (SA6). For the dashboard 826-380510.

1 – starter switch;
2 – the test lamp.

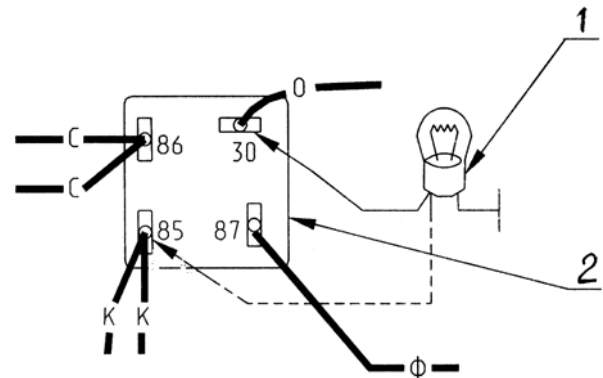

Fig. 10. Checking the integrity of the circuits of the starter solenoid switch 738.3747-30:

1 – test lamp.
2 – starter solenoid switch.

E. Check the integrity of the circuits and units of the starter interlock system with the gearbox engaged as well as of the automatic disconnection of the starter after starting the engine:

a) check the integrity of the circuit from the interlock relay (K6) to the switch SA11 on the gearbox casing. To do this, connect the test lamp between the terminal “+” of the storage battery and the terminal “88” of the relay (wire K4), (Fig. 11). When it will be done,

- the lamp shall be lit when the gearbox lever is set to the neutral position and intact circuit being checked;
- the lamp shall not be lit when moving the gearbox lever to the OFF position or, if there is a fault in the circuit being checked.

b) Check the integrity of the connection to the body at the terminal "86" (wire Г) of the interlock relay.

NOTE! The permanent “ground” jumper between the relay bracket and the dashboard casing.

c) Check the integrity of the circuit from the starter interlock relay (K6) to the alternator terminals "Д", (Fig. 12) when the engine is not running and battery disconnect switch is set to the ON position:

- connect one wire of the test lamp to the relay terminals "85" (wire P) and another – to the tractor body;
- bridge shortly the terminals "+" and "Д" on the alternator.

The test lamp shall be lit.

If the lamp is not lit, the circuit is broken.

ATTENTION! After checking remove the jumper.

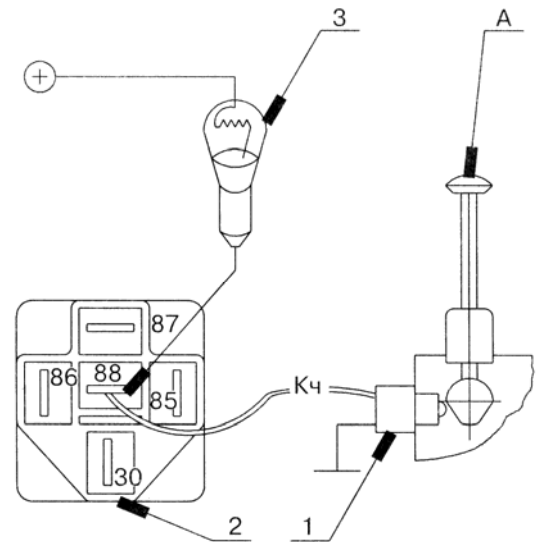

Fig. 11. Checking the integrity of the interlock circuits to the switch on the gearbox casing:

1 – interlock switch SA11;

2 – starter interlock relay K6;

“A” – neutral position of the gearbox control.

Note! Energize the test lamp (3) from the central fuse or from the starter.

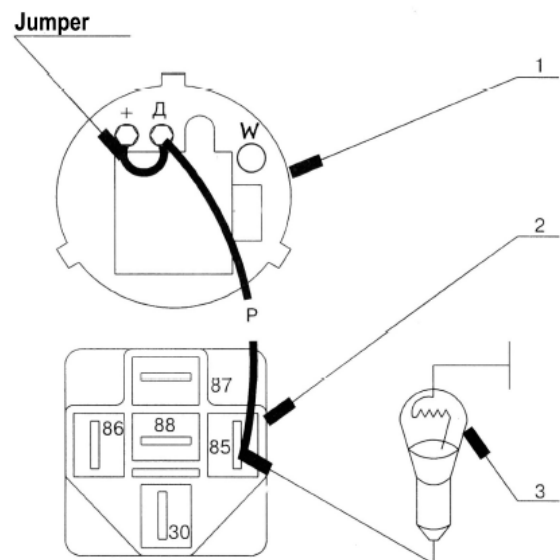

Fig. 12. Checking the integrity of the circuit from the interlock relay K6 to the terminals “Д” of the alternator “G1”:

1. Alternator;

2. Interlock relay;

3. Test lamp.

d) Check the operability of the interlock relay (K2) (Fig. 13):

- connect the test lamp between the relay terminal "30" (wire C) and battery terminal "+".

The lamp shall be lit, when the gearbox lever is set to the neutral position.

- bridge shortly the terminals "+" and "Д" of the alternator with a jumper.

The test lamp shall become dim.

If the above operating mode of the test lamp fails and the electrical circuits checked according to the described above items a, b and c, replace the interlock relay "K6".

ATTENTION! After checking, remove the jumper.

F. The starter is not switched off automatically after starting the engine:

- check the voltage at the terminal "Д" of the alternator (at the engine rotational speed exceeding 500 rpm. The voltage shall exceed 8 B;
- check the working condition of the starter interlock relay and its circuits.

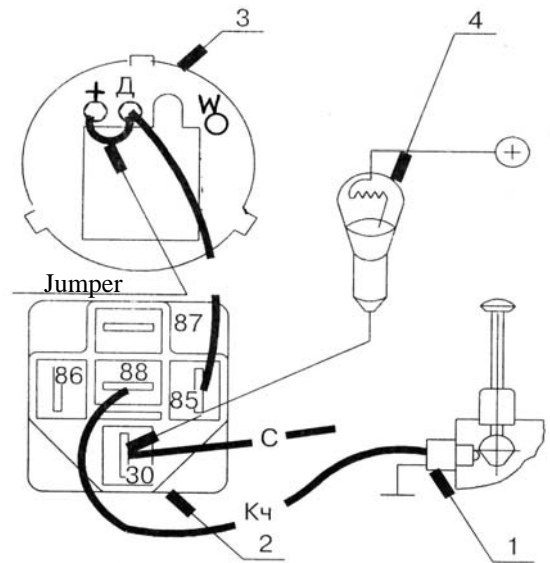



Fig. 13. Checking the operability of the interlock relay K6:

- 1 – Interlock switch SA11;
- 2 – Starter interlock relay;
- 3 – Test lamp.

2.2. Electric torch pre-heater (ETPH).

The ETPH control system (A2) has the following peculiarities (see Fig. 3):

1. The ETPH coil is powered up by the key switch (SA12) located on the instrumentation dashboard.
2. The additional resistor R1 if connected serially into the coil circuit.
3. When closing the contacts "30" and "87", the ETPH relay (K8) shunts the additional resistor. The relay winding is connected into the circuit in parallel to the starter solenoid switch (K7) and operates with in the same mode with the latter.
4. Simultaneously with warming up the ETPH coil, the test lamp  in the pilot lamp block HG2 on the instrumentation dashboard.
5. When the pilot lamp operation will be changed from the steady lighting to the blinking, start the engine. On switching on the starter, the current from the terminals "CT" of the starter switch (SA6) is passed through the second pair of contacts of the switch (SA15) to the electric torch pre-heater solenoid valve, which operates, the fuel is fed to the suction manifold and ignited by the preheated coil of the electric-torch pre-heater. At the same time, the contacts of the electric torch pre-heater relay contacts (K8) are closed and the additional resistor is excluded from the circuit that compensates to compensate for the voltage at the electric torch pre-heater coil having occurred due to switching on the starter.

After starting the engine, the starter and relay are de-energized automatically. The additional resistor is connected into the electric-torch pre-heater coil again to protect the same against fusing due to the voltage increase after beginning of the operation of the alternator.



To allow the engine to reach the stable working mode, the work of the electric-torch pre-heater is possible after automatic switching-off of the starter at the cost of continuing to keep the switch SA15 on the on state and of the starter switch in the "II" position.

2.3. Pre-start pre-heating glow plugs

The glow plugs A2 (see Fig. 4) used as starting aids for the turbocharged engines certified according to the European ecological norms (Euro-2).

The control scheme for the glow plugs A2 has the following peculiarities:

1. The glow plugs are energized by turning the key of the starter switch SA6 to the "I" position.
2. The circuit for control of the glow plugs includes the starting-aid pilot lamp , relay glow plug (K1) and glow plug block (glow plug control module) (KT1). Here the relay (K1) is a power relay and the unit (KT1) performs the functions of control of the power relay while tracing the integrity of the circuitry of the glows (A2).

3. When turning the key of the starter switch (SA6) to the "I" position, the current from the storage battery is passed through KT1 and K1 to the plugs A2. The pilot lamp  is lit steadily and, after expiration of 20 s, when the glow plugs will be warmed up to the working temperature, the lamp will be switched to the blinking mode signalling on the readiness of the system to the start. When turning the key of the switch (SA6) to the "II" position (CT), the starter is switched to start the engine. The starting pilot lamp  lights up to indicate that the starting systems are faultless. If the lamp  starts blinking at the frequency of 1.5 Hz, the change gear lever is not in the neutral position or there is a fault in the starting interlock circuit. If the lamp blinks at the frequency of 3.0 Hz, there is a fault in the circuit of the phase winding of the alternator. Eliminate the faults. After starting the engine, the pilot lamp shall become dim.

Checking the operability of the electric torch pre-heater (Fig. 14)

If the electric torch pre-heater does not operate, check the intactness of the ETPH coil and solenoid valve winding by connecting the test lamp to the terminals "+" of the storage battery and to the ETPH terminals in turn:

- a) to the terminals "M5" (coil): the lamp shall light up. If not so, the coil has burned out;
 - b) to the terminals "M6" (valve winding): the lamp shall be lit dimly.
- If the lamp is lit brightly, there is a short circuit in the winding. If the lamp is not lit, the winding is broken.

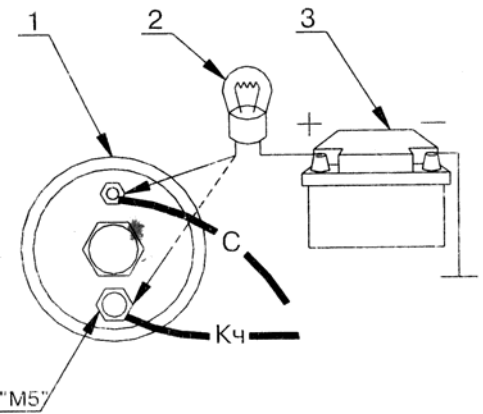

Fig. 14. Checking the operability of the electric torch pre-heater A2.



- 1 – electric torch pre-heater;
- 2 – test lamp;
- 3 – storage battery.

Note: The test lamp shall be energized from the power terminal of the starter or from the storage battery.

ATTENTION: If the starter operates when setting the switch (SA15) to the ON position, the connection of the coil or winding of the ETPH valve is lost. As a result, the current from the switch (SA15) is passed through the coil and ETPH winding to the terminal "CT" of the starter switch (SA6) via solenoid valve control circuit and further – to the starter-energizing circuit.

Replace the ETPH.

Diagnostics of faults in the circuits controlling the glow plugs A2

1. If the test lamp  in the left pilot lamp unit on the instrumentation dashboard after starting the engine is blinking, the relay glow plug (K3) is faulty (sticking of the relay contacts).
2. If the test lamp  blinks when turning the key of the starter switch (SA6) to the "I" position, there is an open circuit between the glow plugs (A2) and the relay (K1).

Checking the operability of the glow plugs (Fig. 15)

If there are difficulties with starting the engine in the winter period of operation: There can be two types of faults in the glow plugs: internal short circuit causing the fuse to blow out, or open circuit.

The operability of the glow plugs can be checked by means of an ohmmeter: the resistance of the operable glow plug rated at 12 V at the temperature of 20°C shall be 0.4-0.6 Ω and that of the plug rated at 24 V at the temperature of 20°C – 2.0-2.5 Ω .

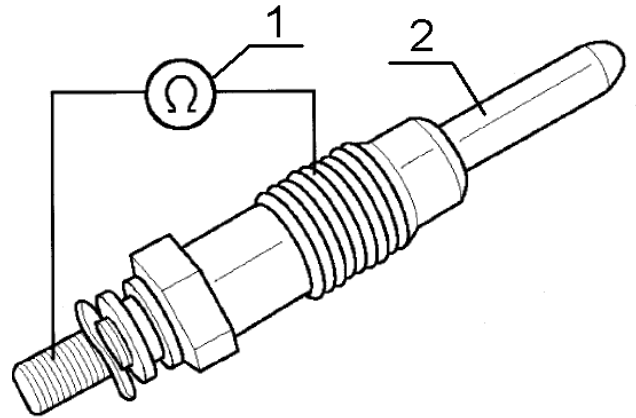
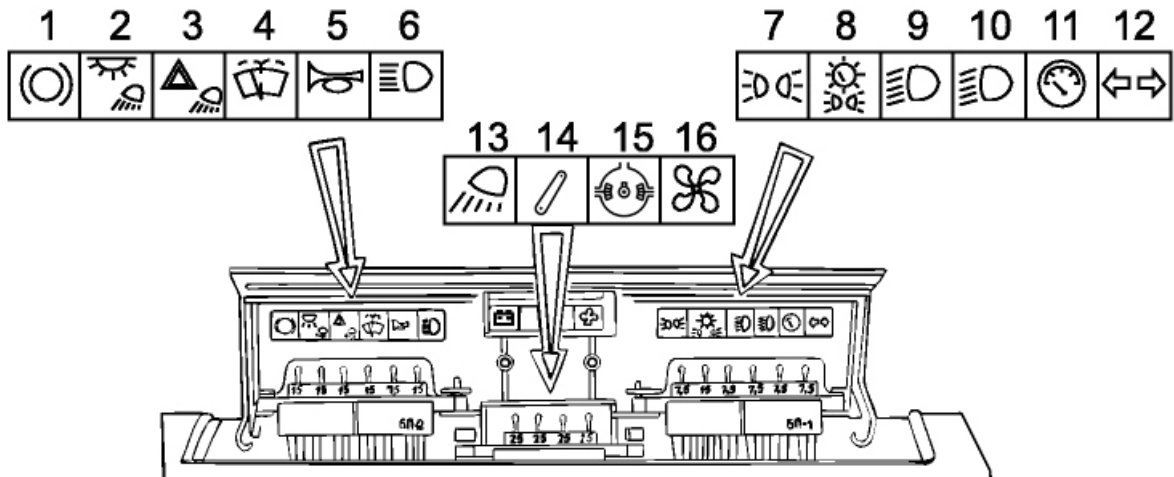

Fig. 15. Checking the operability of the glow plug A2.

1 – Ohmmeter;
2 – Glow plug.



3. Lighting and light signalling system

The protection of the system circuitry by means of the fuses has the following peculiarities:

1) Separate protection of the clearance light circuits at the sides:

- fuse (7) only protects the circuit of the front and rear clearance lights of the left side;
- fuse (8) protects the circuit of the clearance lights of the right side as well as that for illumination of the number plate and instruments.

2) Separate protection of the road headlight lower-beam circuit for each side:

- fuse (10) protects the circuit to the right road headlight;
- fuse (9) protects the circuit to the left road headlight.

3) Protection of the upper-beam circuits of both headlights and pilot lamp of their ON state by means of the fuse (6).

4) Protection of the circuits of the rear working lights and cab lighting lamp by means of the fuse (2) and protection of the front working lights by means of the fuse (13).

5) Protection of the circuits of the stop lights by means of the fuse (1).

6) Protection of the circuits of the turn indicators – by means of the fuse (12) and in the fault signalling mode – by means of the fuse (3).

Troubleshooting of the system

If one of the devices of the lighting and light signalling does not operate, proceed as follows:

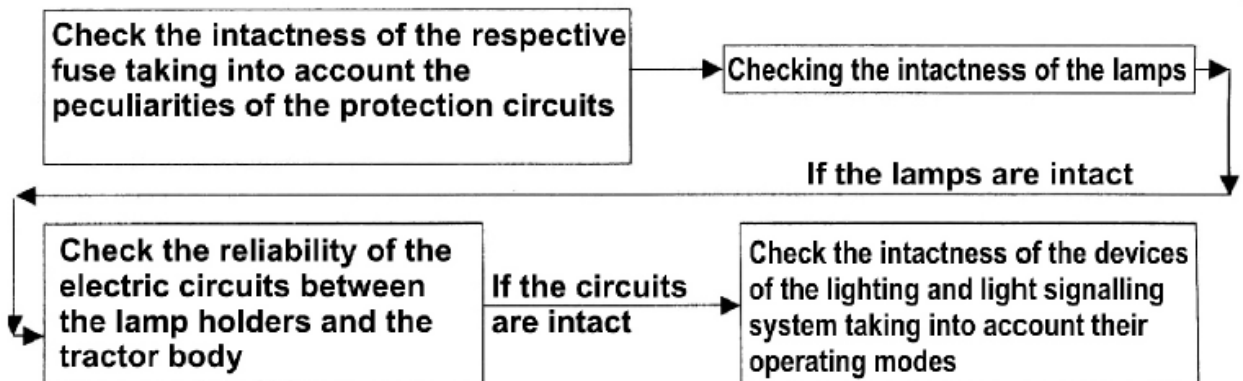

3.1. Clearance light, road and working lights

The clearance and road light as well as the number plate light and lighting devices are switched on by means of the central light switch "SA10".

The key switch "SA10" is energized from the fuse box (F1).

When setting the switch to the second position (the first position corresponds to the switched off state) the supplying voltage is applied through the closed contacts L-V of the switch to the relay and after the relay – to the fuses (8) (15 A) and (7) (7.5 A) (to the wire Г) and further to the front and rear clearance lights of the left and right sides as well as to the number plate light and instrumentation backlight lamps.

When setting the switch (SA10) to the third position the clearance lights continue to be energized, but already through the contacts L-H; besides, due to closing the contacts I-U, the supplying voltage is fed to the steering-wheel mounted switch (SA7) (wire O) for switching on the required beam of the headlights.

a) Lower beam of the road headlights.

The arm of the steering-wheel-mounted switch (SA7) is in the top fixed position – the voltage is applied through its contacts to the fuses (10) (7.5A) and (9) (7.5 A) (wire C) and through the relay (K8) and further – to the circuits of the lower beams of the right (Φ) and left (Г) sides. The lower beam relay (K8) unloads the contacts (SA7) in the lower beam circuit.

b) Upper beam of the road headlights. The arm of the steering-wheel-mounted switch is in the bottom fixed position: the supplying voltage is applied through the relay (K6) (wire P) to the fuse (6) (15 A) (wire Φ) and further – to the upper beam circuit (wire 3).

The upper beam relay (K6) unloads the contacts (SA7) in the upper beam circuit.

c) Signalling by switching on the upper beam for short time.

The arm of the steering-wheel-mounted switch is moved to the top unfixed position. When it will be done, the upper beam of the headlights is switched on irrespectively of the position of the central light switch (SA10). It is achieved due to breaking the circuit of the switch (SA10) by the steering-wheel-mounted switch (SA7) so that the voltage is applied from the box (F1) through the wires 3, K4 (SA6) to the switch (SA7) (wires K4) while bypassing the central light switch (SA10).

The front E3, E4 and rear E8, E9 working lights and cab lighting lamp E7 are supplied from the storage batteries GB1, GB2 through the fuse boxes F3 (25A) and F4 (15A) and switches S2, S3.

Adjusting the road headlights

The headlights should be adjusted as follows:

- Mark out the screen as shown in Fig. 16. When doing this, mark the line of the centres of the headlights A-A on the screen at the distance equal to the height of location of the centres of the headlights above the ground level, and the lines B-B₁ and E-E₁ – at the distance C (the distance between the centres of the headlights in the horizontal plane). The distance should be measured immediately on the tractor. The air pressure in the tyres shall correspond to the recommended norms;
- Place the tractor on a flat level area perpendicularly to the screen at the distance of 10 m from it to the lenses of the front headlights so that the longitudinal plane of symmetry of the tractor would intersect the screen along the line O-O₁;
- Switch on the lower beam and adjust firstly the position of one headlight (close another headlight with a piece of dark cloth) and then – of another headlight having loosened preliminarily their fasteners on the bracket.

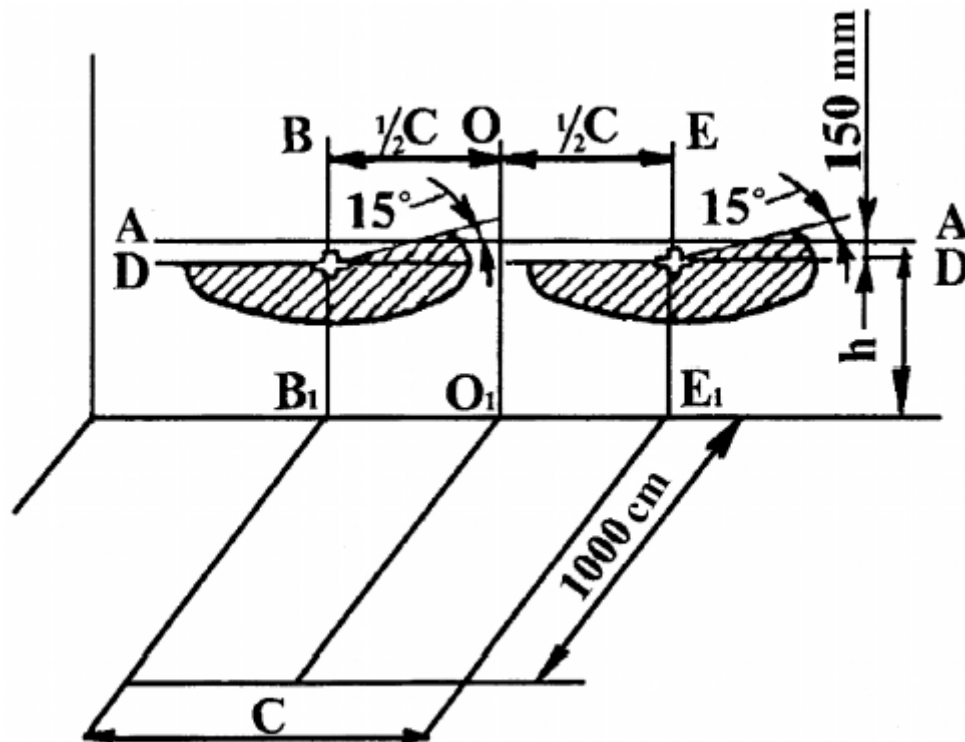

Fig. 16. Marking up the screen and adjusting the front headlights

- A-A – line of the centres of the headlights;
- D-D – line located lower than the line A-A by 150 mm;
- O-O₁ – symmetry line of the screen;
- B-B₁ – vertical axis of the light spot of the left headlight;
- E-E₁ – vertical axis of the light spot of the right headlight.

The light of the headlights is considered to be adjusted, if the centre of the light spot on the screen corresponds to that shown in the picture and the light spots from both headlights are at equal height.

3.2. Turn indicators

The blinking mode of lighting of the signalling lamps (СЛ) of the turn indicators is provided by the flasher (KH2).

The functioning and correctness of operation of the signalling lamps (СЛ) is monitored by means of the two pilot lamps (КЛ) of the tractor and trailer located in the right block of pilot lamps (HG1).

The circuit of the turn indicators is supplied when setting the starter and instrumentation switch (SA6) to the "I" position.

On turning the arm of the steering-wheel-mounted switch (SA7) clockwise or counter-clockwise, respectively, the following signal lamps of the turn indicators light up:

- of the right side (wire Ч);
- of the left side (wire Г).

On setting the switch of the turn indicators (SA7) to the ON position, the current flows in the circuit and its value is fixed by the electronic part of the flasher, which specifies the operating mode of the signalling lamps (СЛ) with the blinking frequency of 90 ± 30 cycles per minute as well as the operating mode of the two signalling lamps (КЛ) (of the tractor and trailer) corresponding to the load in the circuits.

The pilot lamps (КЛ) of the turn indicators of the tractor and trailer are connected permanently to the instrumentation supply circuit (fuse (11)) and their second (minus) lead shall be connected to the terminals "C" (pilot lamps of the tractor, wire Ф) and "C2" (pilot lamps of the trailer, wire P) of the flasher (KH2).

The voltage is supplied from the box (F1) through (SA6) to the power supply relay (K2) (terminal "85") and further through the terminal "87a" to the fuse (12) of the box (F2) to the fault signalling switch (SB1) flasher of the turn indicators (wire Ж, terminal "49"), terminal "49a" and further to the steering-wheel-mounted switch (SA7) (wire 3).

The operating mode of the pilot lamps depends on the operable state of the signalling lamps and, respectively, on their total current load created in the electric circuit by the lit signalling lamps of the tractor and trailer:

Variant 1: the tractor operates with the trailer:

- a) The signalling lamps are intact – both lamps (КЛ) are lit (of the tractor and trailer);
- b) One of the three signalling lamps (СЛ) on the tractor or trailer is faulty: the pilot lamp (КЛ) of the trailer is not lit while that of the tractor continues blinking;
- c) Two or free signalling lamps (СЛ) of one side are faulty: neither pilot lamp (КЛ) is lit.

Variant 2: the tractor operates without trailer:

- a) The signalling lamps (СЛ) are intact: the pilot lamp of the tractor is blinking and the pilot lamp of the trailer is not lit.
- b) One or both signalling lamps are faulty: the pilot lamp of the tractor is not lit.

Deviation from the specified operating mode of the pilot lamps can be caused by:

- using the signalling lamps with the rating differing from the required one (lamps of the type A12-21);
- poor contacts in the specified circuits.
- fault of the flasher (KH2).

3.3. Fault signalling

The tractors are provided with emergency light signalling which makes it possible to switch on the front and rear turn indicators simultaneously in blinking mode in case of emergency.

The emergency fault signalling is switched on by the switch (SB1) located on the instrumentation dashboard, which is connected into the circuit of the flasher of the turn indicators (KH2). Depending on the position of the switch (SB1) the voltage is applied to the flasher of the turn indicators and pilot lamp from one of two fuses over independent circuits:

1) The fault signalling switch (SB1) is set to the OFF position – the switch pushbutton is sunk:

- from the fuse (12) to the terminal "2" of the switch and further through its contacts to the terminal "4", which is connected with the terminal "49" of the flasher (KH2). The flasher and signalling lamp (СЛ) operate in the mode of the turn indicators as described above (see item 9).

2) The fault signalling switch (SB1) is set to the ON position – the switch pushbutton is released, the lamp embedded in the button is blinking:

- the voltage supplied from the fuse (3) provides the operation of the fault signalling when the starter and instrumentation switch (SA6) is set to the OFF position. The contacts of the switch (SB1) (terminals 1,3,7) bridge the circuits of the signalling lamps of the turn indicators of the left and right side and the terminal "49a" of the flasher that ensures the synchronous blinking of all the signalling lamps of the turn indicators.

3.4. Signalling of braking the tractor

The stop light is switched on by the switch (SB2) located on the bracket to the right under the cab floor. The switch rod is actuated by the arm of the right brake pedal through a swinging bracket.

The voltage is permanently applied to the switch (SB2) (wire P) from the fuse (1). When stepping on the brake pedal, the pedal lever ceases to act on the bracket and through the latter on the switch rod.

The rod returns to the initial position under the action of the spring, the contacts of the switch (SB2) are closed and the voltage is applied (through wire 3) to the stop light lamps of the rear light signalling units (EL19) and (EL20) and to the terminals "6" of the receptacle for connecting the agricultural implements (XA9.1).

The beginning of switching on the stop light is adjusted by bending the shelf of the bracket coupled with the brake pedal arm and acting upon the switch rod by its back side.

3.5. Signalling of application of the parking brake

The signalling of application of the parking brake is ensured by the operation of the following devices:

- a) pilot lamp located in the right block of pilot lamps (HG1);
- b) switch (SB3) located on the bracket on the right niche of the cab under the parking brake lever;
- c) flasher relay (KH1) located inside the dashboard on the right. The flasher relay related to the thermobimetallic type provides the intermittent operating mode of the pilot lamp.

The pilot lamp and flasher relay are supplied from the fuse (11) after setting the starter and instrumentation switch (SA6) to the "I" position.

Current path: Box (F1), wire 3-3, wire 3a-3, SA6, wire 3б-Ж, terminal "85" power supply relay (K4), terminal "87a", fuse "2" of the box (F2), wire 16-C, terminal "-" relay (KH1), terminal "L", terminal "1" of the block (HG1), terminal "+" of the relay (KH1), wire 16a-3, 16б-3, switch (SB3). Pay attention to connecting the flasher relay:

Terminal "-": (wire C) the voltage as applied from the fuse 2.2;

Terminal "L": (wire K) to the pilot lamp in the block (HG1);

Terminal "+" - (wire 3) to the switch (SB3) and further to the tractor body.

On applying the parking brake, the rod of the switch (SB3) is released and its contacts are closed. The terminal "+" of the relay is connected with the body, the test lamp lights up, the bimetallic contact of the relay (KH1) begins warming up and its periodical opening and, respectively, flashing of the pilot lamp on the instrumentation dashboard begins as well. The fastening holes of the bracket have oval shape that makes it possible to adjust the moment of the beginning of setting the switch to the ON position.

3.6. Connection diagram of the road train sign lamps and radio equipment

The three lights of the road train sign are fitted under the windscreen on the cab roof and mounted in a separate bracket.

The switch of the lights (SA1) is mounted on the upper panel in the tractor cab. On setting the switch to the ON position, the lamps (EL4), (EL5) and (EL6) of the three orange lights and switch key illumination light up.

The power supply voltage of 12 V is applied from the unit (F1) through the wire 1з-Ж, 1е-Ж, to the box (F4), fuse 4.5 (15A) and wires 45-0, 45a-0 to the switch (SA1). The power supply voltage of 12 V for radio equipment (A1, WA1, BA1, BA2) is applied from the box (F1) to the starter switch (SA6). When turning the switch key to the "III" position is applied to the radio equipment through the wires 21-P, 21a-P and fuse (FU1) including in the complete set of the radio recorder.

4. Cab heating and ventilation system

The electric circuitry of the system has the following peculiarities:

- The winding of the heater interlock relay K3 serving for preventing the discharge of the storage battery when switching on the heater with the engine not running is connected between the terminal “Д” of the alternator (G1) (wire P) and the tractor body (wire Г);
- To provide for reduced rotational speed of the fan in case of installation of the motor with the power of 90 W (M1), the power supply circuit comprises an additional resistor (R1). The increased rotational speed is provided by the respective position of the switch (SA4) supplying the fan motor with bypassing the additional resistor.
- In case of installation of the motor with the power of 120 W (M7) to the heater unit, the circuit from the fuse “1” (25A) of the box F3 (wire K4) to the switch (SA4) comprises the relays (K10) for setting the minimum rotational speed and (K9) for setting the maximum speed. The said relays ensure the protection of the contacts of the switch (SA4) against overcurrent.
- When the engine has been started and the voltage at the terminal “Д” of the alternator has exceeded 8 V, the interlock relay (K3) operates, its contacts “87-30” become closed and the supplying voltage is applied to the switch (SA4) (wire C3) (contact “L”).

The switch (SA4) applies the supply voltage to the motor and provides the necessary rotational speed of the fan.

4.1. Diagnostics and troubleshooting

In case of failure in the operation of the electric part of the heating and ventilation system, the search of the faults shall be performed in the following sequence:

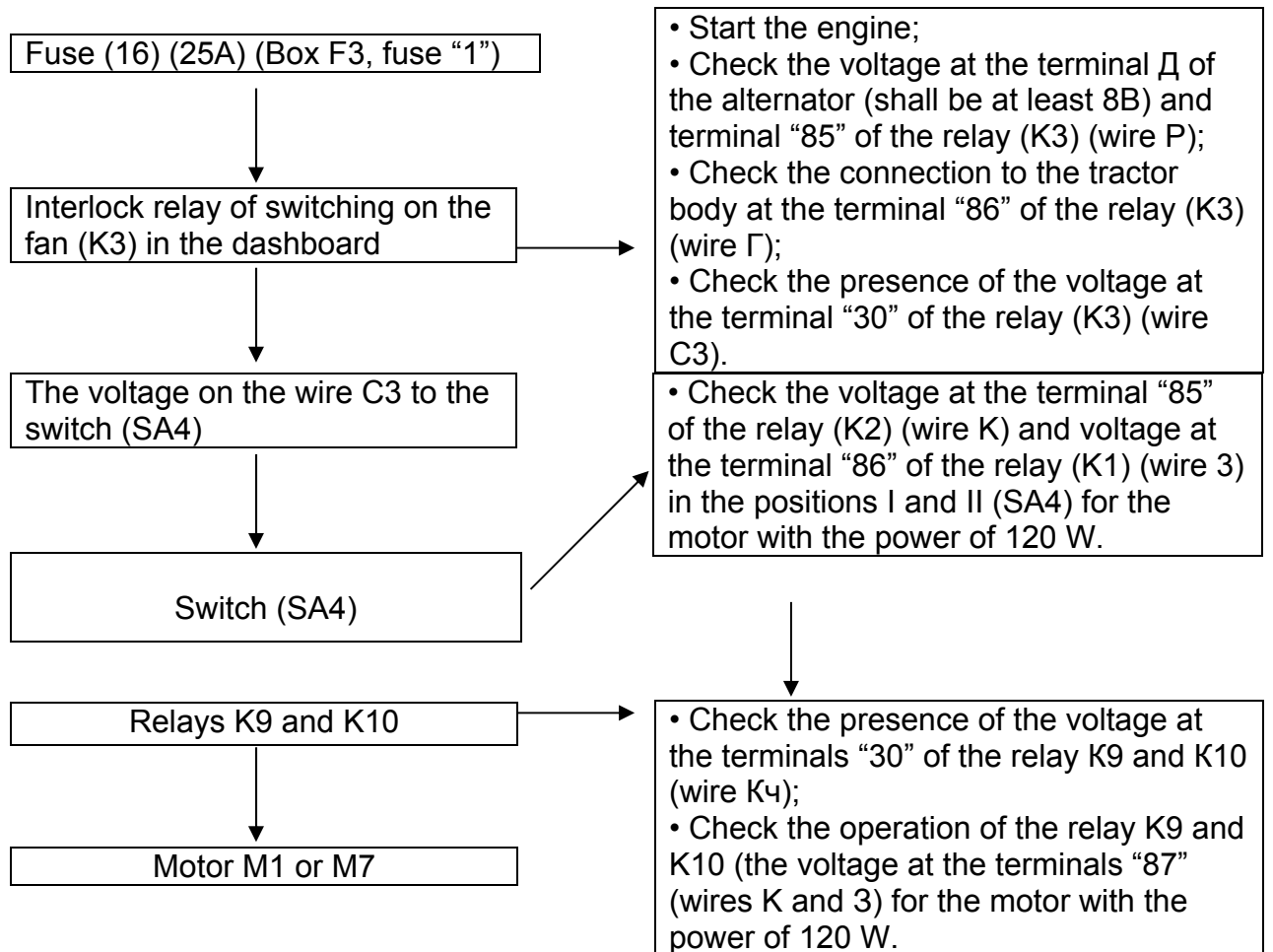

5. Windscreen wiper

5.1. Front windscreen wiper

The Belarus tractors are equipped with a single-brush windscreen wiper with the two-speed pantograph-type lever mechanism with parking the brush:

- brush length: 650 mm;
- lever length: 600 mm;
- cleaning angle: 89-94 degrees;
- number of double strokes per minute:

a) Speed I: 34-46;

b) Speed II: 47-63.

The motor with a reduction gear consists of the commutator-type motor, worm reduction gear and rocker mechanism. The second speed is provided at the cost of the three brush in the commutator assembly of the motor.

The windscreen operation modes are switched over by a three-position key switch (SA5) located in the shield of the cab roof.

The electric circuits of the windscreen wiper and washer are protected by a fuse (4) (15 A). From their, the voltage is applied permanently to the terminal "L" of the switch (SA5) and to the terminal of the end switch on the casing of the motor with a reduction gear (wire Г) as well as to the rear windscreen wiper (M5) and through the switch (SA9) – to the windscreen washer (M4).

One row of the contacts of the switch (SA5) L, V and H commutates the current supplied to the motor brushes:

- Position I: the first speed: the contacts L-V (wires Г-3) are closed;
- Position II: the second speed: the contacts L-H (wires Г-K) are closed.

The second row of the contacts of the switch (SA5) jointly with the end switch serve for automatic stopping of the brush in the parked position. The three contacts of the end switch are mounted on the cover of the motor with a reduction gear. Closing the contacts in the required combination is provided by the contact disk fastened to the driven pinion of the reducing gear.

As the motor rotates, the terminal of the end switch with the wire Б is connected periodically with:

- terminal "+" (wire Г) – outside the parked position;
- terminal "-" (wire К4) – in the parked position.

On setting the windscreen wiper switch to the ON position, its contacts of the second row (with the wires 3 and C) are closed and the supply voltage is applied to the motor through the closed contacts of the end switch of the windscreen wiper and provide the its operation in the first-speed mode until the brush reaches the parked position. As the brush enters the zone of the parked position, the end switch breaks the power supply circuit and then becomes connected to the tractor body so that the motor is short-circuited and its stop in the parked position is accelerated due to the dynamic braking.

The diagnostics and troubleshooting shall be performed in the following sequence:

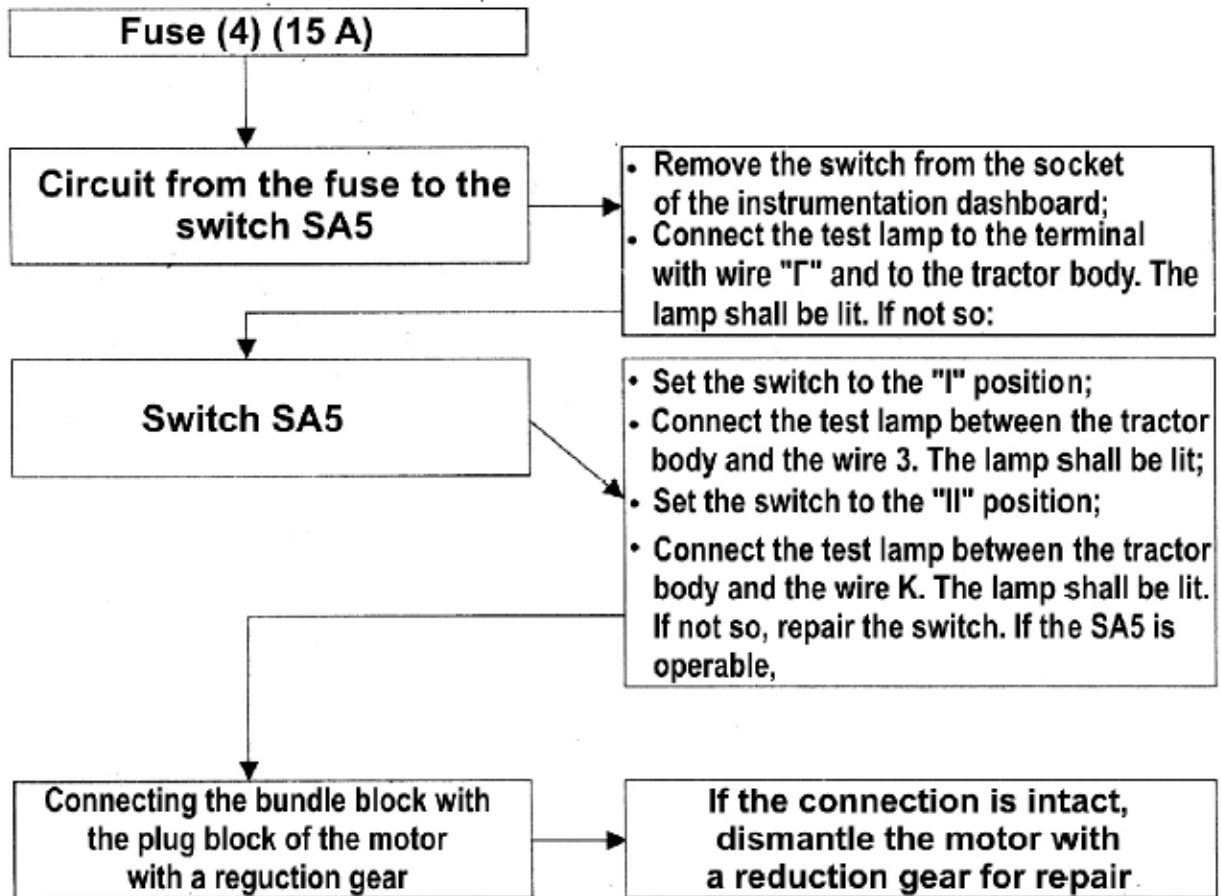

5.2. Rear screen wiper

The electrical single-brush, single-lever and single speed rear screen wiper has the following characteristics:

- Brush length: 460 mm;
- Lever length: 420 mm;
- Cleaning angle: 110 ± 7 degrees;
- Number of double strokes per minute: 45.

The switch of the rear screen wiper is located on its decorative cover.

The power supply of the rear screen wiper is provided from the circuit of the windscreen wiper through a single-terminal block located at the switch (SA5).

5.3. Windscreen washer

The electric windscreen flusher (M4) with external position of the electric pump. The direction of spraying the fluid from the nozzle is adjusted by turning the ball in the fluid supply sector.

The fluid pressure in the system shall be at least 60 kPa.

The duration of the continuous operation shall be not more than 10 seconds.

The windscreen washer is switched on by the switch (SA9). The windscreen washer circuit is protected by the fuse (4) (15 A).